

MODULE 1: METAL CARBONYLS

Key words:

Carbon monoxide; transition metal complexes; ligand substitution reactions; mononuclear carbonyls; dinuclear carbonyls; polynuclear carbonyls; catalytic activity; Monsanto process; Collman's reagent; effective atomic number; 18-electron rule

MODULE 1: METAL CARBONYLS

LECTURE #1

1. INTRODUCTION:

Justus von Liebig attempted initial experiments on reaction of carbon monoxide with metals in 1834. However, it was demonstrated later that the compound he claimed to be potassium carbonyl was not a metal carbonyl at all. After the synthesis of $[\text{PtCl}_2(\text{CO})_2]$ and $[\text{PtCl}_2(\text{CO})]_2$ reported by Schutzenberger (1868) followed by $[\text{Ni}(\text{CO})_4]$ reported by Mond et al (1890), Hieber prepared numerous compounds containing metal and carbon monoxide.

Compounds having at least one bond between carbon and metal are known as organometallic compounds.

Metal carbonyls are the transition metal complexes of carbon monoxide containing metal-carbon bond.

Lone pair of electrons are available on both carbon and oxygen atoms of carbon monoxide ligand. However, as the carbon atoms donate electrons to the metal, these complexes are named as carbonyls.

A variety of such complexes such as mono nuclear, poly nuclear, homoleptic and mixed ligand are known.

These compounds are widely studied due to industrial importance, catalytic properties and structural interest.

Carbon monoxide is one of the most important π - acceptor ligand. Because of its π - acidity, carbon monoxide can stabilize zero formal oxidation state of metals in carbonyl complexes.

2. SYNTHESIS OF METAL CARBONYLS

Following are some of the general methods of preparation of metal carbonyls.

Direct Combination:

Only $\text{Ni}(\text{CO})_4$ and $\text{Fe}(\text{CO})_5$ and $\text{Co}_2(\text{CO})_8$ are normally obtained by the action of carbon monoxide on the finely divided metal at suitable temperature and pressure.

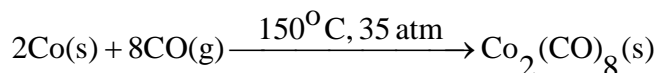
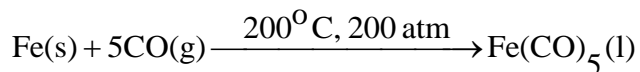
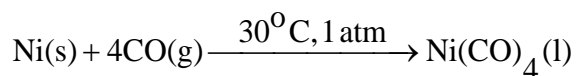

Reductive carbonylation:

Many metallic carbonyls are obtained when salts like $\text{Ru}(\text{acac})_3$, CrCl_3 , Re_2O_7 , VCl_3 , CoS , $\text{Co}(\text{CO})_3$, CoI_2 etc. are treated with carbon monoxide in presence of suitable reducing agent like Mg , Ag , Cu , Na , H_2 , AlLiH_4 etc.

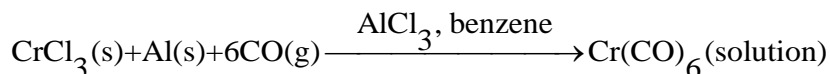
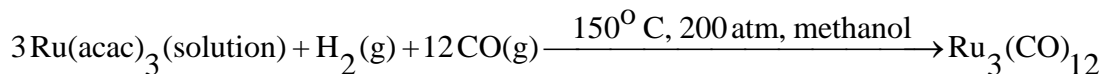

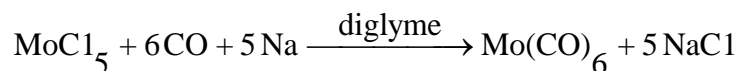
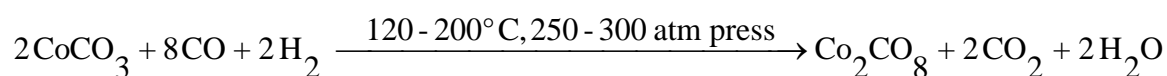
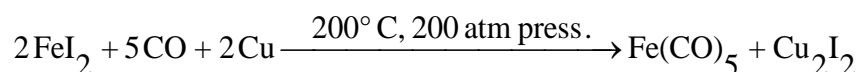
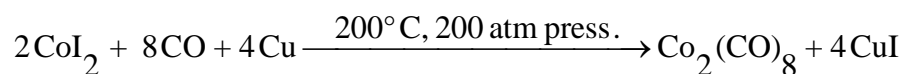
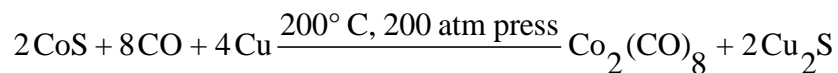
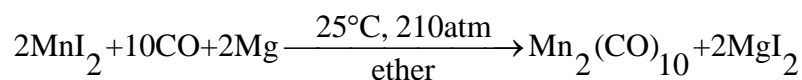

Sometimes CO acts as a carbonylating and reducing agent as under.

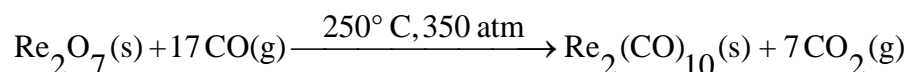
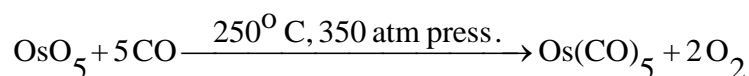

A solution of vanadium chloride in diethylene glycol dimethyl ether, which is acidified by phosphoric acid, gives vanadium hexacarbonyl

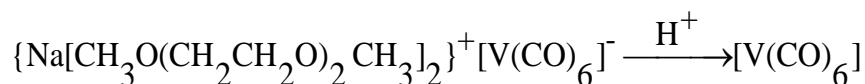
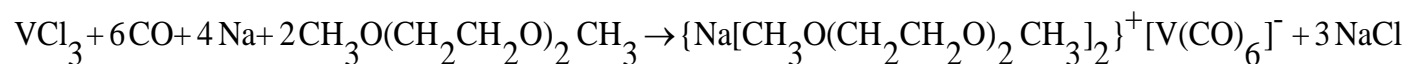

Preparation of mononuclear carbonyls from iron pentacarbonyl.

The labile carbonyl groups in iron pentacarbonyl can be replaced by chloride to give a different metal carbonyl. These reactions are characterized by low yield, which can be improved using high pressure.

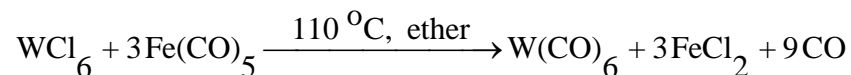
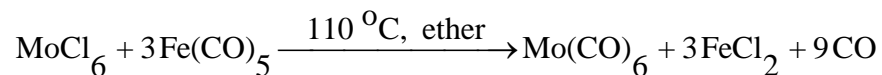
**Preparation of dinuclear carbonyls from mononuclear carbonyls:**

When a cold solution of $\text{Fe}(\text{CO})_5/\text{Os}(\text{CO})_5$ in glacial CH_3COOH is irradiated with ultra-violet light, $\text{Fe}_2(\text{CO})_9/\text{Os}_2(\text{CO})_9$ are obtained.

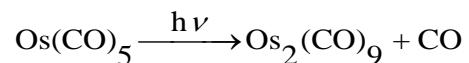
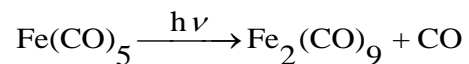
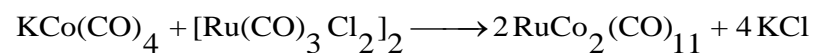
**Preparation of mixed-metal carbonyls by metathesis reaction**

LECTURE #2

3. PHYSICAL PROPERTIES

State:

Majority of the metallic carbonyls are liquids or volatile solids.

Colour:

Most of the mononuclear carbonyls are colourless to pale yellow. $V(CO)_6$ is a bluish-black solid.

Polynuclear carbonyls exhibit are dark in colour.

Solubility:

Metal carbonyls are soluble in organic solvents like glacial acetic acid, acetone, benzene, carbon tetrachloride and ether.

Toxicity:

Due to low melting points and poor thermal stability, they show toxicity related to the corresponding metal and carbon monoxide. Exposure to these compounds can cause damage to lungs, liver, brain and kidneys. Nickel tetracarbonyl exhibits strongest inhalation toxicity. These compounds are carcinogenic over long-term exposure.

Magnetic Property:

All the metal carbonyls other than vanadium hexacarbonyl are diamagnetic. The metals with even atomic number form mononuclear carbonyls. Thus, all the electrons in the metal atoms are paired. In case of dinuclear metal carbonyls formed by metals with odd atomic number, the unpaired electrons are utilized for the formation of metal-metal bonds.

Thermal Stability:

Most of the metal carbonyls melt or decompose at low temperatures. Solid carbonyls sublime in vacuum but they undergo some degree of degradation.

Thermodynamic Stability:

Metal carbonyls are thermodynamically unstable. They undergo aerial oxidation with different rates. $\text{Co}_2(\text{CO})_8$ and $\text{Fe}_2(\text{CO})_9$ are oxidized by air at room temperature while chromium and molybdenum hexacarbonyls are oxidized in air when heated.

4. CHEMICAL PROPERTIES

The metal carbonyls give a variety of chemical reactions.

Ligand substitution reactions:

Substitution of carbon monoxide ligand by various mono dentate and bidentate ligands can be carried out using thermal and photochemical reactions. Monodentate ligands like isocyanides (CNR), cyanide (CN⁻), phosphine (PR₃) and ethers can partially or completely replace the carbonyl group.

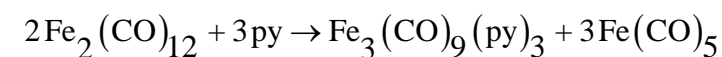
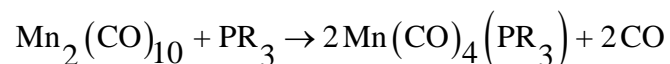
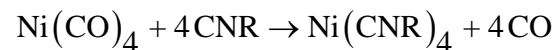
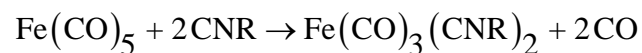

Bidentate ligands like o-phenylene-bis(dimethyl arsine) (diars) and o-phenanthroline(o-phen) can replace carbonyl groups in the multiple of two.

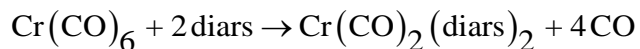
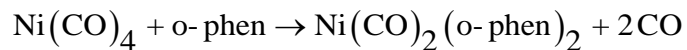

Reaction with metallic sodium:

Metallic sodium and its amalgam can be used to reduce the metal carbonyls.

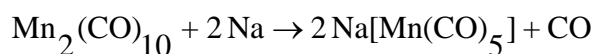
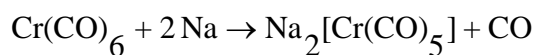

In the above two reactions, the Cr and Mn atoms in their zero oxidation states are reduced to -2 and -1 oxidation states respectively.

Reaction with sodium hydroxide:

The reaction of sodium hydroxide with metal carbonyls results in nucleophilic attack by hydroxide ion on the carbonyl group to give a metal carboxylic acid complex. Upon further action with sodium hydroxide, the carboxylic acid gives up carbon dioxide to form a hydrido anion. The protonation of this anion results in the formation of iron tetracarbonyl hydride as shown below:

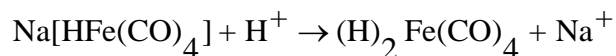
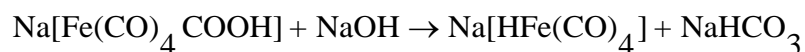
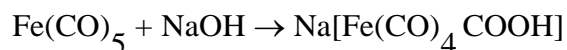

The above reaction is known as Heiber base reaction.

Reaction with halogens:

Most of the metal carbonyls react with halogens to give carbonyl halides

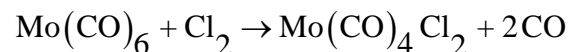
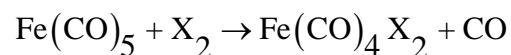

Halogens can cause cleavage in the metal-metal bonds in case of polynuclear carbonyls

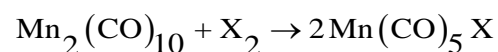

Some carbonyls undergo decomposition upon reaction with halogens

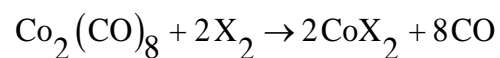
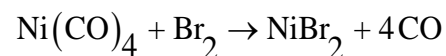
**Reaction with hydrogen:**

Some of the carbonyls can be reduced by hydrogen to give carbonyl hydrides

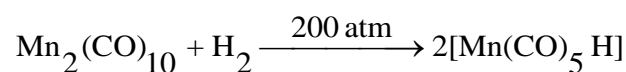
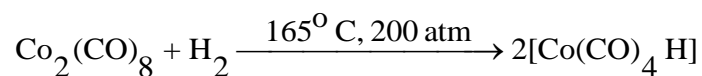

Even though, these compounds are named as hydrides, they are known to behave as proton donors. The neutral hydrides like $[\text{Co}(\text{CO})_4\text{H}]$ and $[\text{Mn}(\text{CO})_5\text{H}]$ behave as acids as shown below:

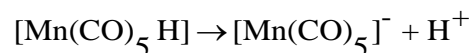
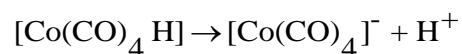

The anionic hydrides like $[\text{HFe}(\text{CO})_4]^-$ are true hydrides and behave as reducing agents for alkyl halides as shown below:

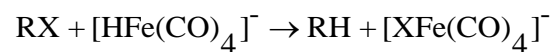

Reaction with nitric oxide:

A good number of metal carbonyls react with nitric oxide to give carbonyl nitrosyls.

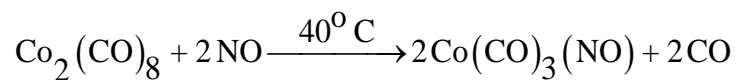
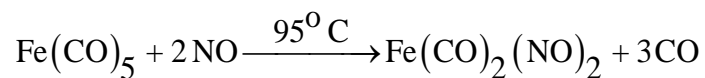

The reaction between iron pentacarbonyl and nitric oxide involves replacement of three carbonyl groups by two nitric oxide molecules. Electronically, this is equivalent as nitric oxide is a three electron donor ligand whereas carbon monoxide is a two electron donor.

LECTURE #3**5. BONDING IN METALLIC CARBONYLS****Carbon monoxide:**

In order to understand the bonding in metal carbonyls, let us first see the MO diagram of carbon monoxide.

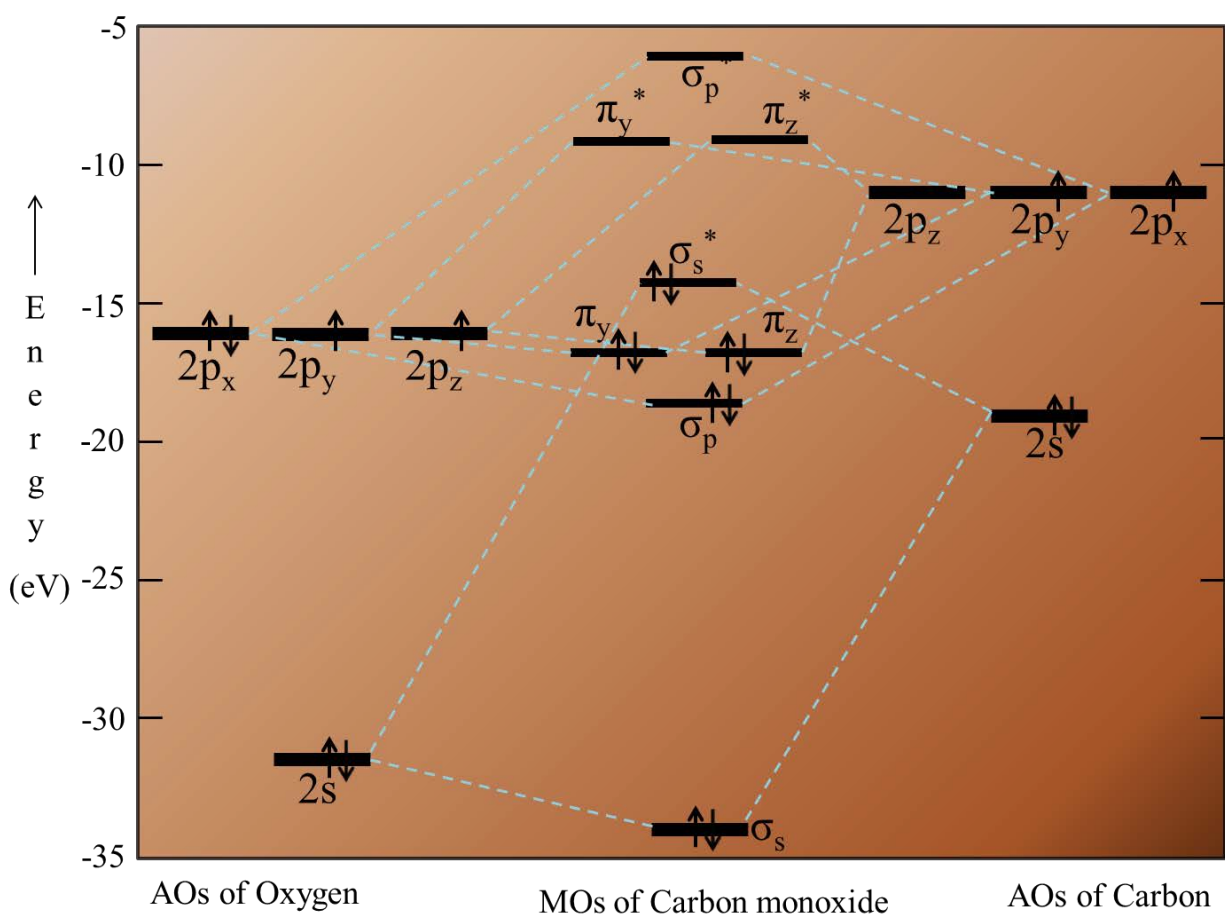

Figure: Molecular Orbital Energy Level Diagram of Carbon Monoxide

The order of energy of the molecular orbitals and the accommodation of ten electrons of the carbon monoxide can be shown as:

$$(\sigma_s^b)^2 (\sigma_p^b)^2 (\pi_y^b = \pi_z^b)^4 (\sigma_s^*)^2 (\pi_y^* = \pi_z^*)^0 (\sigma_p^*)^0$$

(σ_s^*) is the highest occupied molecular orbital (HOMO) which can donate the lone pair of electrons for the formation of a $OC \rightarrow M$ σ bond.

$(\pi_y^* = \pi_z^*)$ are the lowest unoccupied molecular orbitals (LUMO) which can accept the electron density from an appropriately oriented filled metal orbital resulting into formation of a $M \rightarrow CO$ π bond.

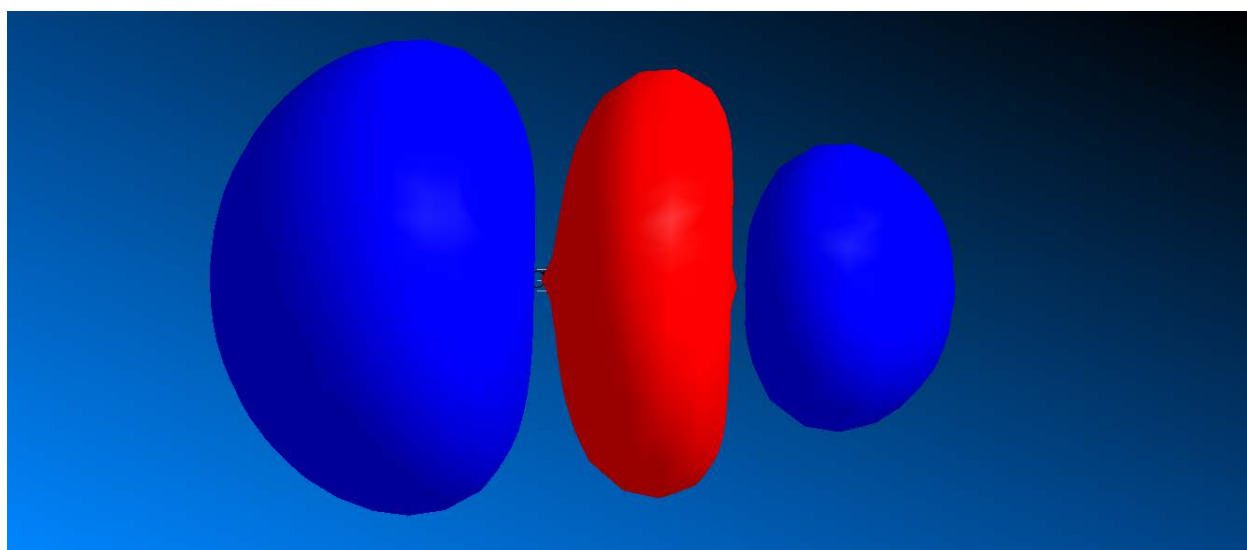

Figure: Highest occupied molecular orbital (HOMO) of carbon monoxide

(N.B: Red colour is for positive sign of the wave function while the blue colour indicates negative sign of the wave function)

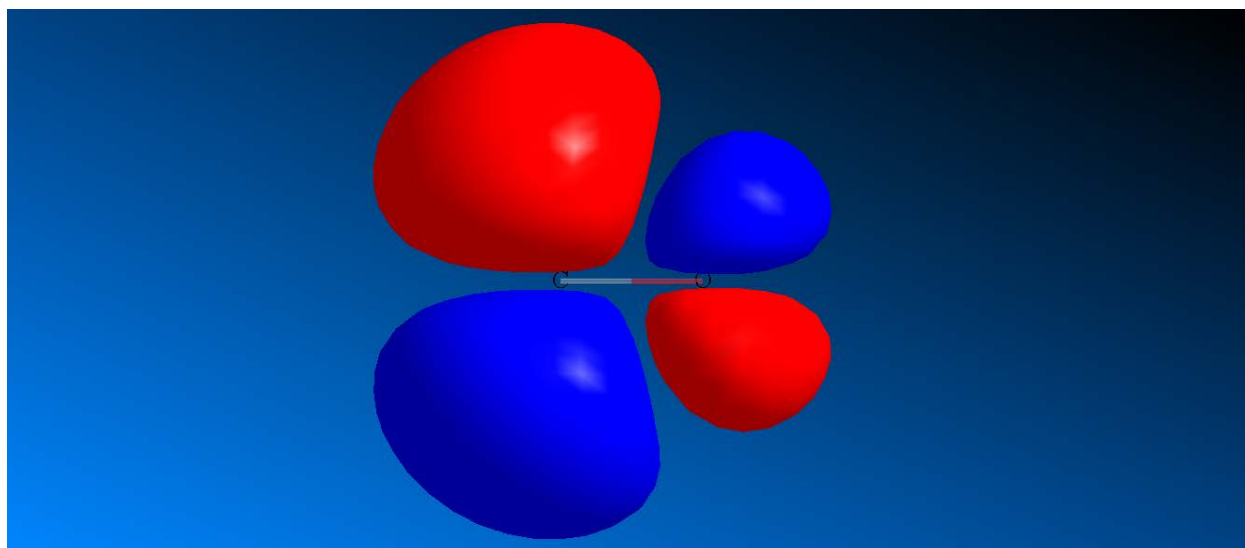

Figure: Lowest unoccupied molecular orbital (LUMO) of carbon monoxide

(N.B: Red colour is for positive sign of the wave function while the blue colour indicates negative sign of the wave function)

The nature of M-CO bonding in mononuclear carbonyls can be understood by considering the formation of a dative σ -bond and π -bond due to back donation.

Formation of dative σ -bond:

The overlapping of empty hybrid orbital (a blend of d, s and p orbitals) on metal atom with the filled hybrid orbital (HOMO) on carbon atom of carbon monoxide molecule results into the formation of a $M \leftarrow CO$ σ -bond.



Figure: Formation of a $M \leftarrow CO$ σ -bond in metal carbonyls.

Formation of π -bond by back donation:

This bond is formed because of overlapping of filled $d\pi$ orbitals or hybrid $dp\pi$ orbitals of metal atom with low-lying empty (LUMO) orbitals on CO molecule. i.e. $M \xrightarrow{\pi} CO$

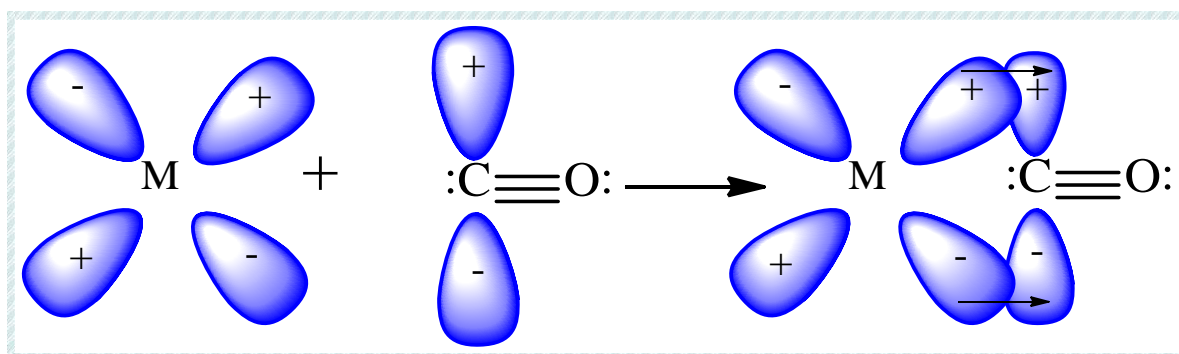

Figure: Formation of $M \xrightarrow{\pi} CO$ bond by back donation in metal carbonyls.

Bridging CO groups:

In addition to the linear M-C-O groups, the carbon monoxide ligand is also known to form bridges. This type of bonding is observed in some binuclear and polynuclear carbonyls. It is denoted by μ_n -CO, where n indicates the number of metals bridged. While n=2 is the most common value, it reaches to be 3 or 4 in certain less common carbonyls.

In a terminal M-C-O group, the carbon monoxide donates two electrons to an empty metal orbital, while in μ_2 -CO group, the M-C bond is formed by sharing of one metal electron and one carbon electron.

LECTURE #4

6. INFRARED SPECTROSCOPY

The carbonyl groups can have two modes of stretching

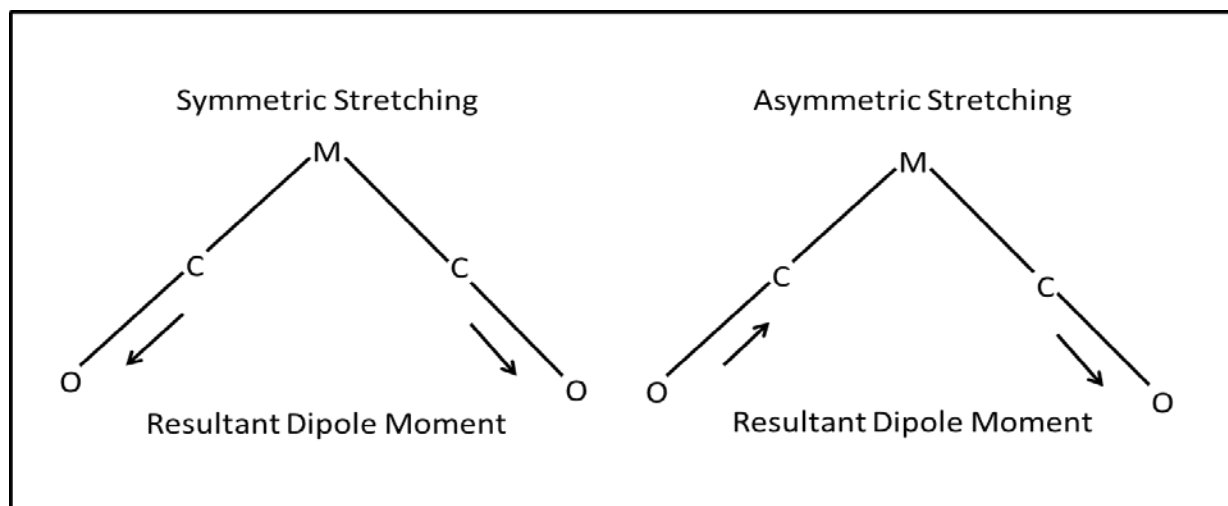

Figure: Stretching modes of carbonyl.

Since both of these modes result in change in dipole moment, two bands are expected in the infrared spectra of a terminally ligated carbon monoxide.

The infrared and Raman spectroscopy together can be used to determine the geometry of the metallic carbonyls.

A mono nuclear pentacarbonyl can exist both in square pyramidal and trigonal bipyramidal geometry. Performing infrared spectra after calculating the IR active and Raman active bands in both the possible geometries can provide information about the actual geometry of the molecule.

Infrared spectroscopy of metallic carbonyls helps in determining the bond order of ligated carbon monoxide.

The C-O bond order and the frequency related to its absorption are directly proportional. Thus, it can be predicted that the frequencies of absorption will be in the order shown below:

Free CO > metal carbonyl cation > neutral metal carbonyl > metal carbonyl anion.

Table: Comparison C-O stretching in representative metal carbonyls

<i>Carbonyl</i>	<i>Type</i>	<i>C-O stretching frequency (cm⁻¹)</i>
<i>Carbon monoxide</i>	Free	~2150
<i>Mn(CO)₆⁺</i>	Cation	~2090
<i>Cr(CO)₆</i>	Neutral	~2000
<i>V(CO)₆⁻</i>	Anion	~1850

It is also used to distinguish the terminal and bridging carbonyl groups.

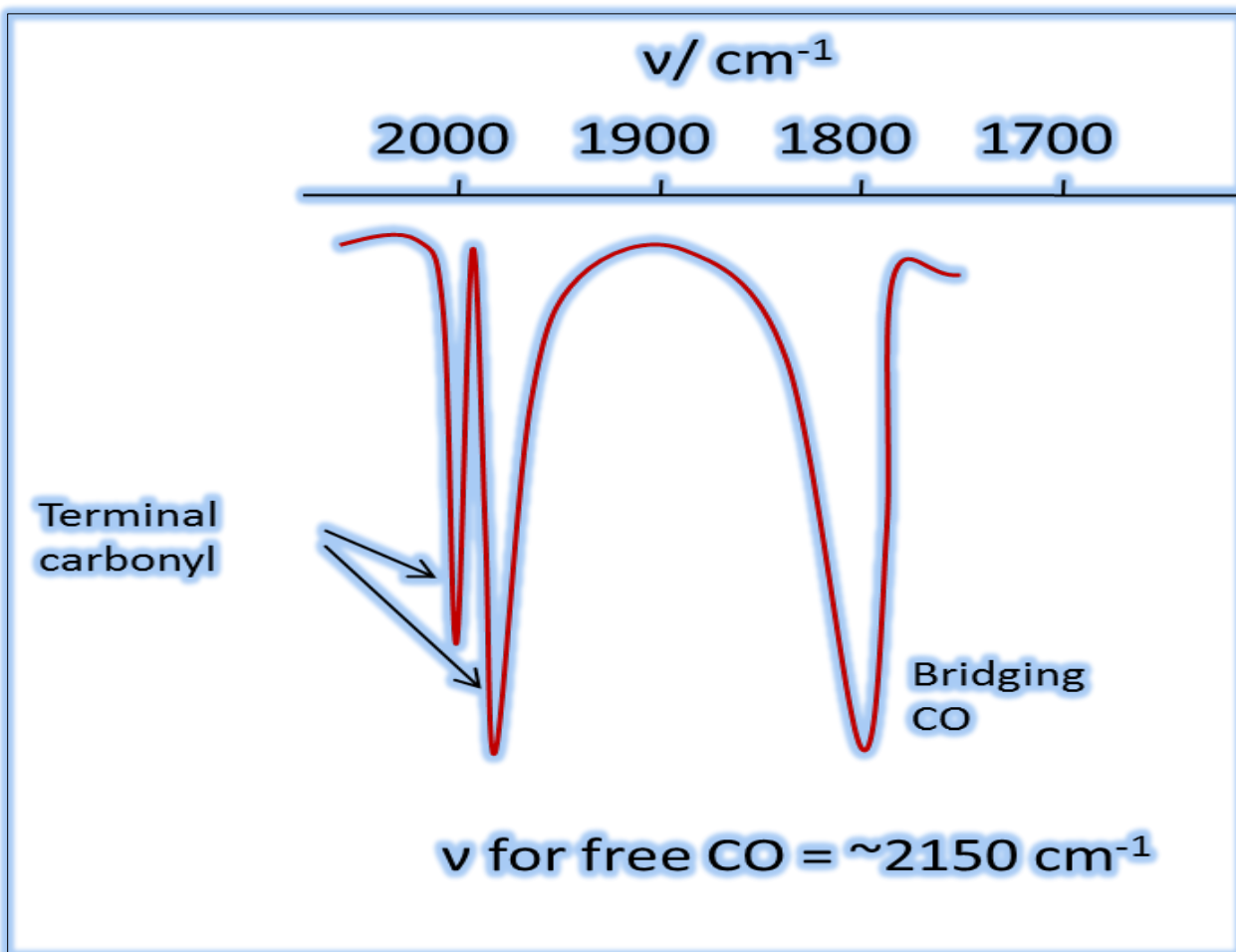

Figure: A partial infrared spectrum showing terminal and bridged carbonyl.

The C-O bonding in terminal carbonyl groups is stronger than the bridged carbonyl groups. Therefore, it is possible to differentiate the terminal carbonyls which absorb in the region of 2050–1900 cm^{-1} from the bridged carbonyls absorbing below 1900 cm^{-1} .

The change in the intensity of bands related to carbonyl group can provide information for the kinetic studies of the substitution reactions involving replacement of carbonyls.

CLASSIFICATION OF METAL CARBONYLS

Table: Different types of metal carbonyls

<i>Type</i>	<i>Examples</i>
<i>Mononuclear carbonyls</i>	[Ti(CO) ₆] ⁻² , [V(CO) ₆], [Cr(CO) ₆], [Fe(CO) ₅], [Ni(CO) ₄]
<i>Dinuclear carbonyls</i>	[Mn ₂ (CO) ₁₀], [Fe ₂ (CO) ₉], [Co ₂ (CO) ₈]
<i>Polynuclear carbonyls</i>	[Fe ₃ (CO) ₁₂], [Co ₄ (CO) ₁₂], [Co ₆ (CO) ₁₆]
<i>μ₂Bridging carbonyls</i>	[Fe ₂ (CO) ₉], [Co ₂ (CO) ₈], [Fe ₃ (CO) ₁₂], [Co ₄ (CO) ₁₂]
<i>μ₃Bridging carbonyls</i>	[Rh ₆ (CO) ₁₆] (Four triply bridged carbonyl groups)
<i>Carbonyl hydrides</i>	[HMn(CO) ₅], [HCo(CO) ₄], [H ₂ Fe(CO) ₄]

7. MONO NUCLEAR CARBONYLS

Ni(CO)₄, Nickel tetracarbonyl:

Preparation:

It can be prepared by passing carbon monoxide over nickel in the temperature range of 60-100 °C.

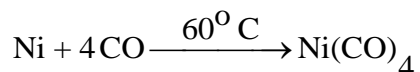

It can be made by heating nickel iodide with carbon monoxide in the presence of copper which acts as a halogen acceptor.

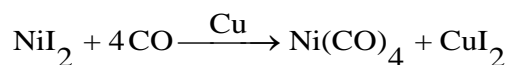

It can also be prepared by passing carbon monoxide through alkaline suspensions of nickel sulphide or nickel cyanate.

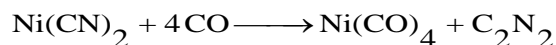
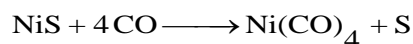

Properties:

It is a colourless liquid having melting point -25°C , boiling point 43°C and decomposition temperature in the range of $180\text{--}200^\circ\text{C}$.

It is insoluble in water but dissolves in organic solvents.

It reacts with concentrated sulphuric acid along with detonation

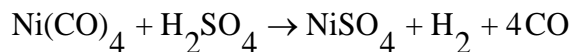

It reacts with moist nitric oxide to give deep blue coloured compound.

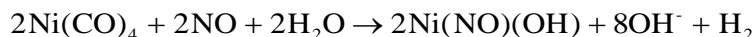

Passing gaseous hydrochloric acid in the solution of nickel tetracarbonyl results in the decomposition

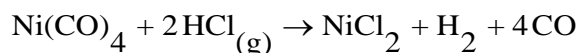

Uses:

Since Ni(CO)_4 , on heating, decomposes to metallic nickel, it is used in the production of nickel by Mond's process.

It is used for plating nickel on other metals.

It is used as a catalyst for synthesis of acrylic monomers in plastic industries.

Structure:

Nickel tetracarbonyl has a tetrahedral geometry with Ni-C bond lengths of 1.5 \AA . It is also found to be diamagnetic.

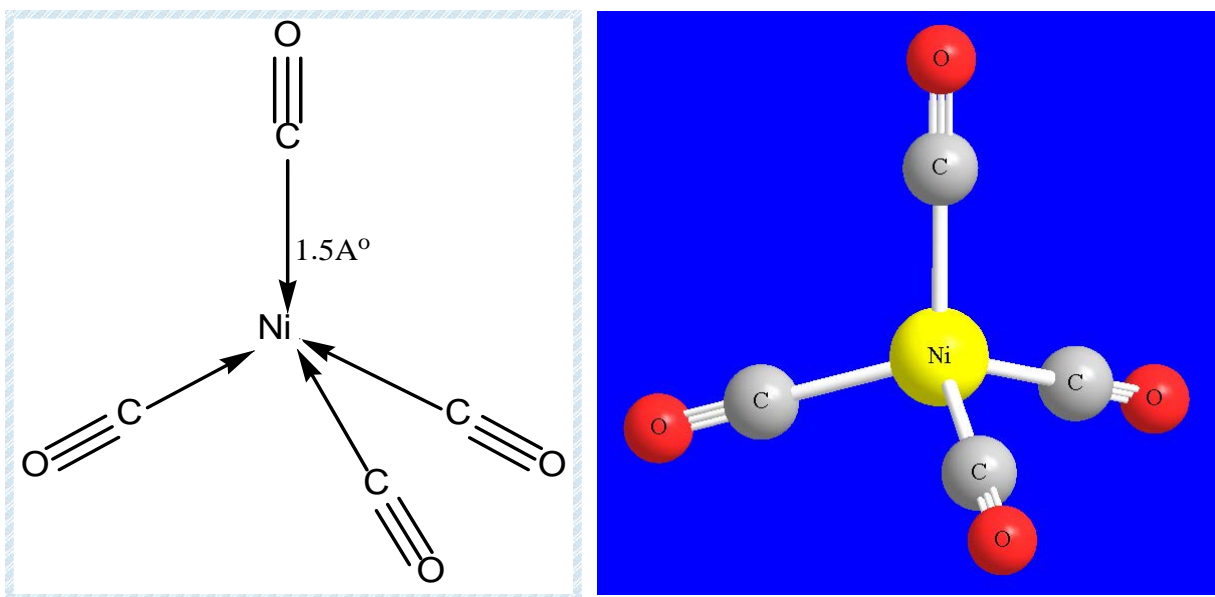

Figure: Tetrahedral structure of nickel tetracarbonyl



ordinary 2-d image



Red-Blue 3-d (Anaglyph) image

IMPORTANT NOTE

1. The movies with suffix red-blue can be viewed as real 3-d by wearing cyan (red)-blue (magenta) glasses. These glasses are available at cheap rates from optician; they are also available on internet. They can also be prepared by painting the plain glasses with permanent markers of said colour. The left eye glass should be cyan and right one should be magenta.
2. A movie showing how to make 3d glasses is available on the following link:
<http://www.youtube.com/watch?v=sIEn9z0oBE8&noredirect=1>

(View movie: [Ni\(CO\)₄ 3D.flv](#), [Ni\(CO\)₄ Red-Blue glasses.flv](#))

The structure of Ni(CO)₄ can be explained by considering sp³ hybridization of Ni atom. Since it is diamagnetic, all the ten electrons present in the valence shell of Ni atom (Ni = 3d⁸ 4s²) get

paired in 3d orbitals. Thus the valence shell configuration of Ni atom in $\text{Ni}(\text{CO})_4$ molecule becomes $3d^{10} 4s^0$. $\text{OC} \rightarrow \text{Ni}$ bond results by the overlap between the empty sp^3 hybrid orbital on Ni atom and the HOMO on C atom in CO molecule as shown below.

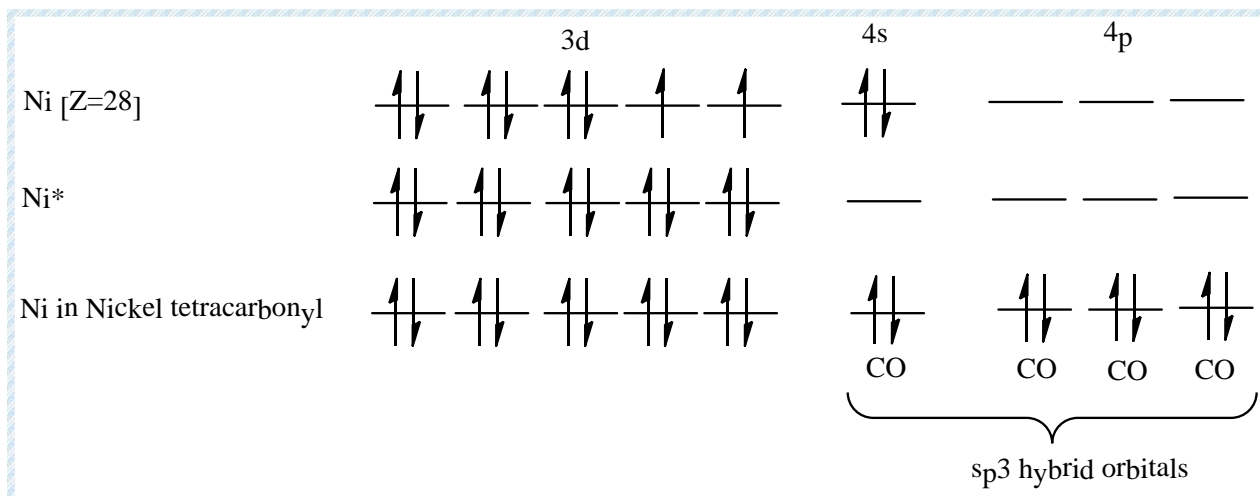

Figure: sp^3 hybridization of nickel atom in nickel tetracarbonyl

Acceptance of four electron pairs by nickel in zero oxidation state severely increases the electron density on the nickel atom. According to the electro neutrality principle given by Pauling, the atoms in a molecule share the electron pairs to the extent such that charge on each of the atom remains close to zero. Thus, the nickel atom donates back some electron density from the filled d-orbitals to the low-lying empty (LUMO) orbitals on CO molecule resulting into formation of a double bond. i.e. $\text{M} \xrightarrow{\pi} \text{CO}$.

LECTURE #5

Fe(CO)₅, Iron pentacarbonyl:

Preparation:

It can be prepared by passing carbon monoxide over iron powder at high temperature and pressure.

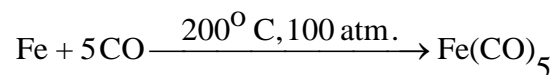

It can also be prepared by carbonylation of ferrous sulphide/iodide in presence of Cu-metal, which acts as a reducing agent.

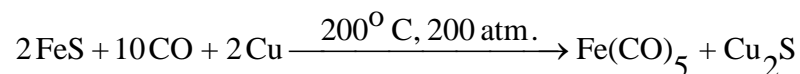

Properties:

It is a pale yellow liquid having melting point -20°C , boiling point 103°C and decomposition temperature around 250°C .

It is insoluble in water but soluble in glacial acetic acid, methanol, diethyl ether, acetone and benzene.

Cold solution of iron pentacarbonyl in glacial acetic acid undergoes dimerization under the influence of ultra-violet light.

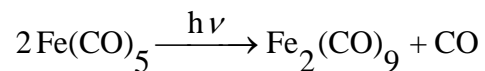

It is readily hydrolysed by water and acids.

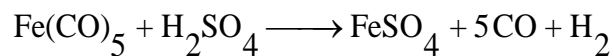

The reaction of sodium hydroxide with iron pentacarbonyl results in nucleophilic attack by hydroxide ion on the carbonyl group to give a metal carboxylic acid complex. Upon further action with sodium hydroxide, the carboxylic acid gives up carbon dioxide to form a hydrido anion. The protonation of this anion results in the formation of iron tetracarbonyl hydride (Heiber base) as shown below:

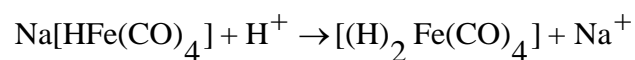
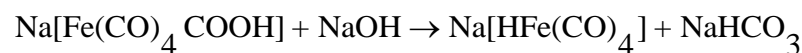
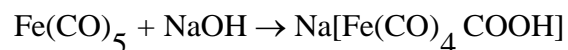

It reacts with sodium metal in liquid ammonia to give carbonylate anion.

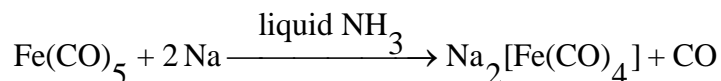

This compound is popularly known as Collman's reagent in organic synthesis. The Collman's reagent is used in aldehyde synthesis as shown below:

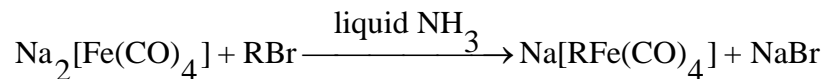

This solution is then treated with triphenyl phosphine followed by acetic acid to give corresponding aldehyde.

It reacts with ammonia to give iron tetracarbonyl hydride and carbamic acid (glycine).

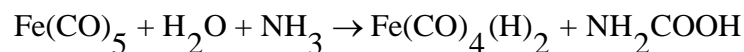

It reacts with halogens in non-aqueous solvents to give stable tetracarbonyl halides.

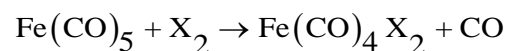

Structure:

The structural studies have suggested trigonal bipyramidal geometry for iron pentacarbonyl. The Fe-C distances are found to be 1.80 Å and 1.84 Å for axial and equatorial bonds respectively.

The molecule is also found to be diamagnetic.

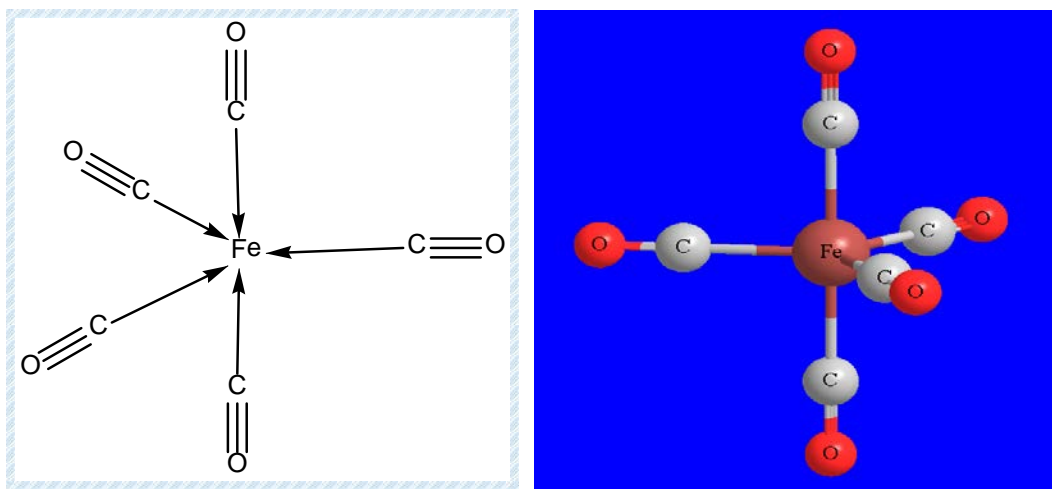

Figure: Trigonal bipyramidal structure of iron pentacarbonyl.

(View movie: [Fe\(CO\)₅ 3D.flv](#) , [Fe\(CO\)₅ Red-Blue glasses.flv](#))

The structure can be explained using dsp^3 hybridization in Fe atom. All eight electrons present in the valence shell of Fe atom ($\text{Fe}:3d^64s^2$) get paired in four 3d orbitals. Thus the valence shell configuration of Fe in $\text{Fe}(\text{CO})_5$ becomes $3d^84s^0$. The $\text{OC}\rightarrow\text{Fe}$ bond results by the overlap

between the empty dsp^3 hybrid orbitals on Fe atom and the HOMO on C atom in CO molecule as shown below.

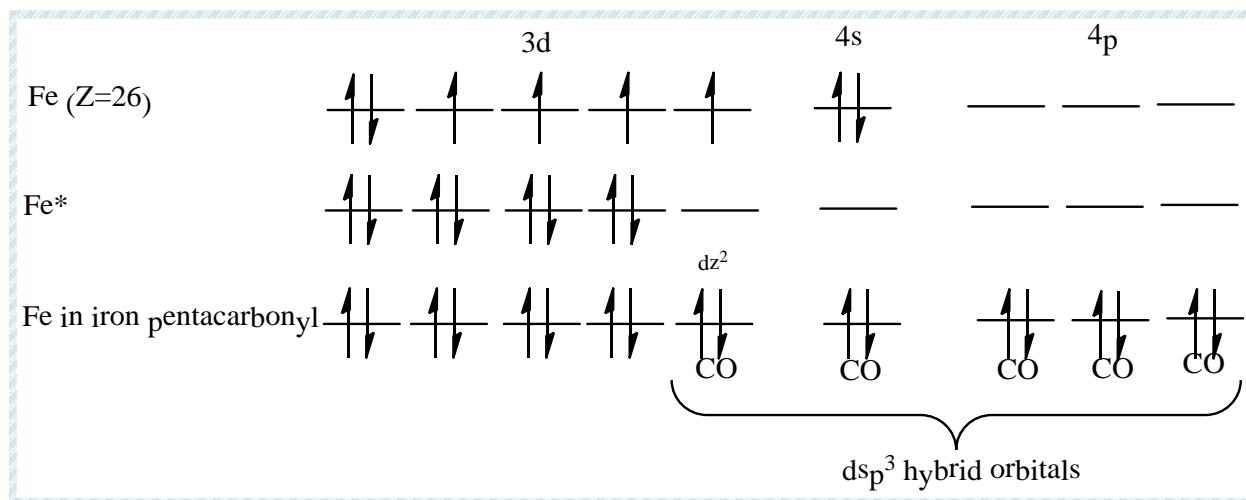
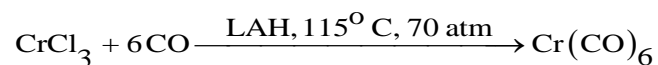

Figure: dsp^3 hybridization in iron pentacarbonyl.

$Cr(CO)_6$, Chromium hexacarbonyl:

Preparation:

It can be prepared by carbonylation of chromium chloride with carbon monoxide using a reducing agent like lithium aluminium hydride (LAH).



An indirect method of preparation involves an action of carbon monoxide on a mixture of Grignard reagent and anhydrous chromium chloride in ether which is followed by decomposition with an acid to give chromium hexacarbonyl.

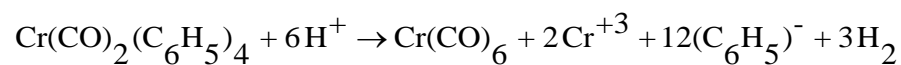
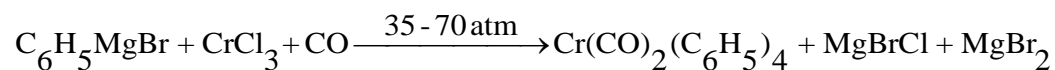

Properties:

It is a white crystalline solid melting above 150 °C and boiling at 220 °C.

It is insoluble in water but soluble in ether, chloroform, carbon tetrachloride and benzene.

It is not attacked by air, bromine, cold aqueous alkalis, dilute acids and concentrated hydrochloric acid as well as sulphuric acid. It is decomposed by Chlorine gas and concentrated nitric acid. It reacts with fluorine at -75 °C to form chromium hexafluoride.

It reacts with sodium metal in liquid ammonia to give carbonylate anion.

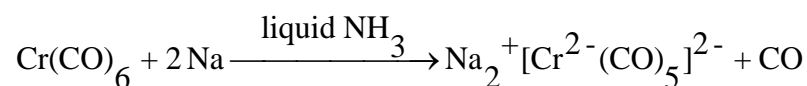

It gives substitution reactions with amines like en and py. At higher temperatures (>150°C) several pyridyl derivatives are formed.

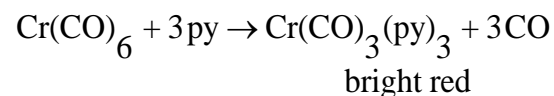
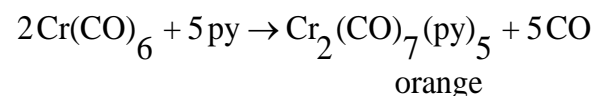
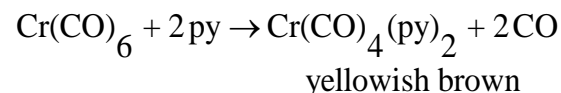
**Structure:**

The structural studies have suggested an octahedral geometry for chromium hexacarbonyl. The Cr-C distance is found to be 1.92 Å while the C-O bond length is 1.16 Å. The molecule is also found to be diamagnetic.

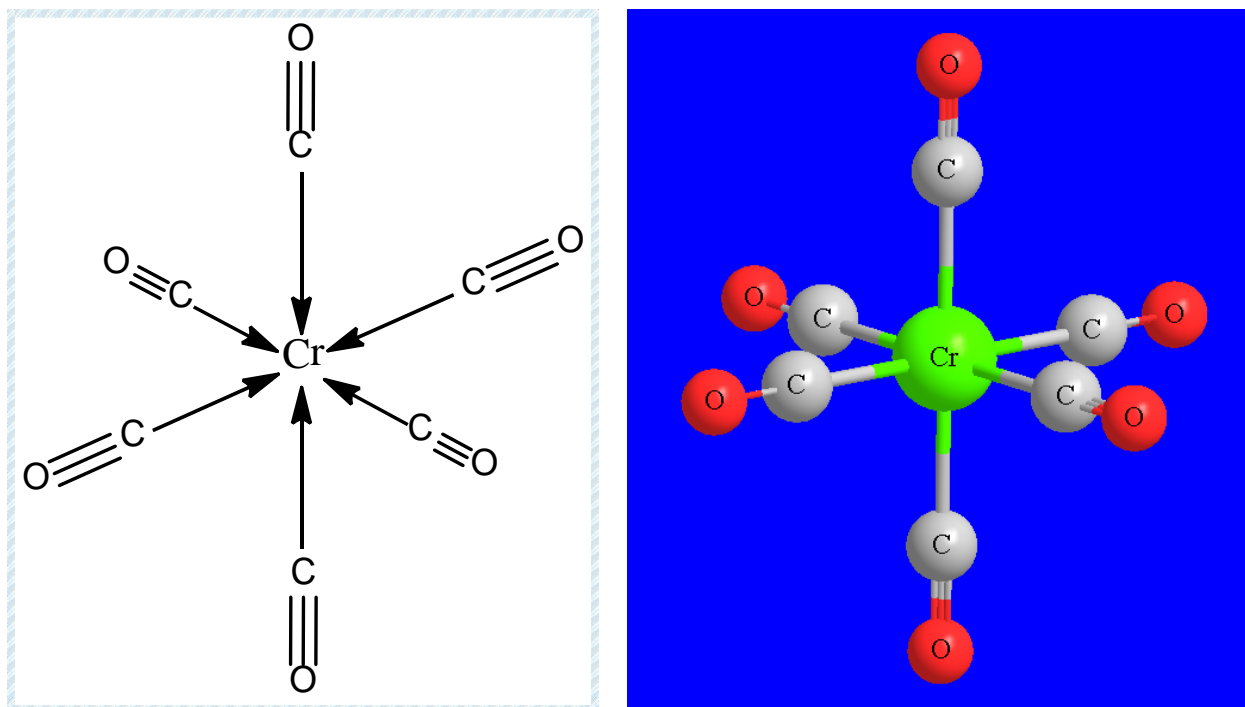

Figure: Octahedral structure of chromium hexacarbonyl.

(View movie: [Cr\(CO\)₆ 3D.flv](#), [Cr\(CO\)₆ Red-Blue glasses.flv](#))

The structure can be explained using d^2sp^3 hybridization in Cr atom. All six electrons present in the valence shell of Cr atom ($\text{Cr}: 3d^54s^1$) get paired in three 3d orbitals. Thus the valence shell configuration of Cr in $\text{Cr}(\text{CO})_6$ becomes $3d^64s^0$. The $\text{OC} \rightarrow \text{Cr}$ bond results by the overlap between the empty d^2sp^3 hybrid orbitals on Fe atom and the HOMO on C atom in CO molecule as shown below.

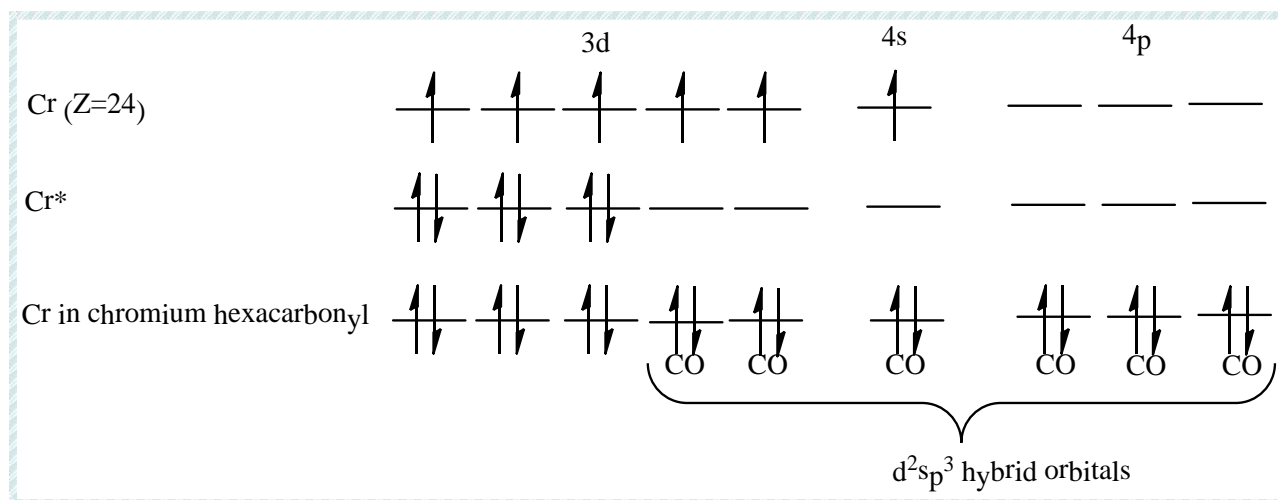

Figure: d^2sp^3 hybridization in chromium hexacarbonyl

The MO energy diagram for $\text{Cr}(\text{CO})_6$ is shown in the figure below. For the molecular orbitals, 12 electrons are contributed from the lone pairs on the carbon atoms of the six carbon monoxide ligands. The metal contributes six electrons while 24 electrons come from the π system of the six ligands. The MOs are occupied by these 42 electrons and the t_{2g} level becomes the highest occupied molecular orbital (HOMO) of the metal carbonyl.

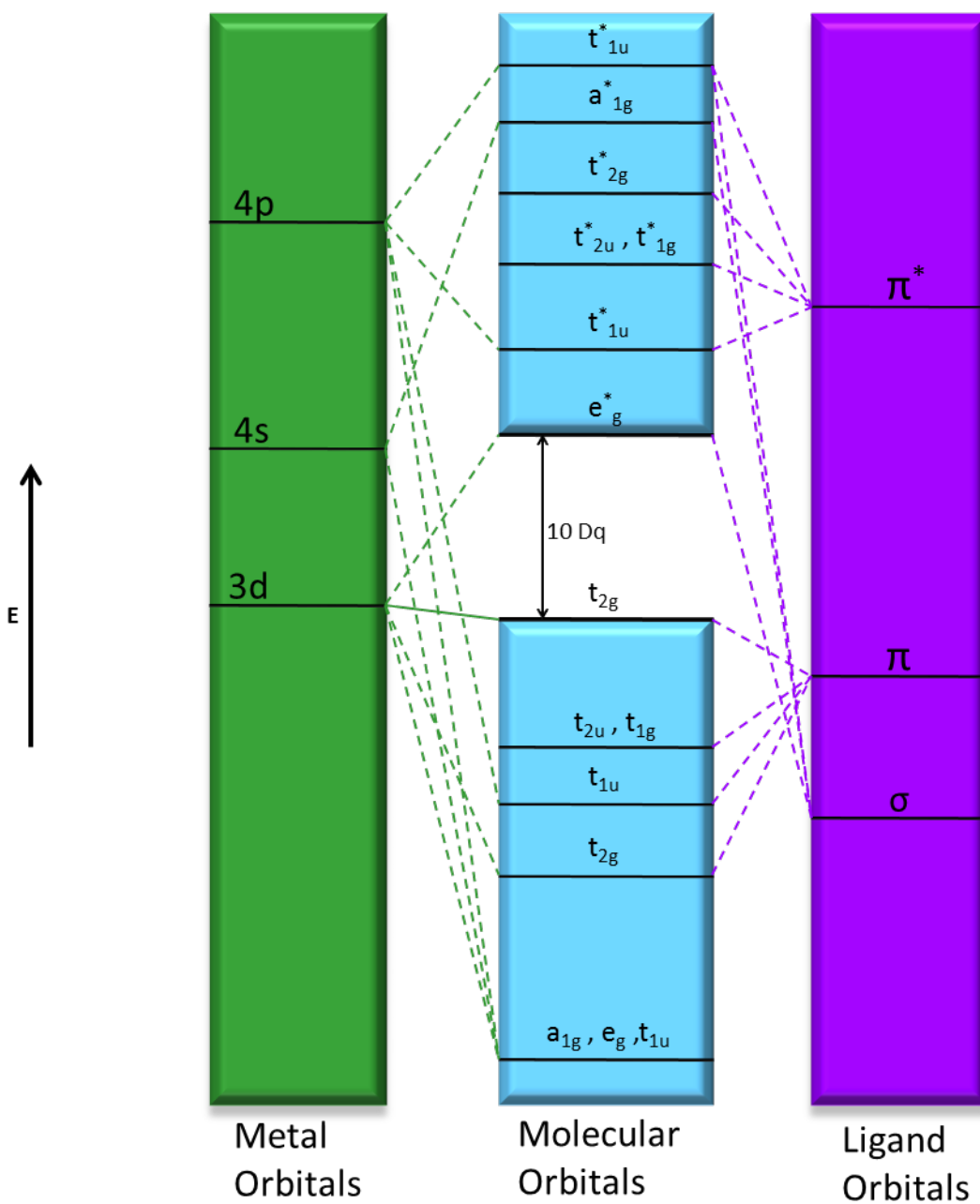

Figure: The MO energy diagram for $\text{Cr}(\text{CO})_6$

The net effect of the π^* orbitals is to increase the magnitude of $10 Dq$ (the splitting between the t_{2g} and e_g levels by lowering t_{2g}^* to a level lower in energy than when no π^* orbitals are involved. Consequently, the complexes are predicted to be more stable when the ligands have π and π^* orbitals available for bonding. The ligand CO may be predicted to bond increasingly strongly with electron releasing metal atoms. The bond order of CO decreases progressively as the π^* orbitals are increasingly populated by $d \rightarrow \pi^*$ donation.

As discussed above, the low-lying empty π^* orbitals on CO allow back bonding from the metal d electrons to the ligand. It has a very pronounced effect on the coordinated C-O bond order.

LECTURE #6**8. POLYNUCLEAR CARBONYLS****Mn₂(CO)₁₀, Dimanganese decacarbonyl:****Preparation:**

It can be prepared by carbonylation of manganese iodide with carbon monoxide using magnesium as a reducing agent.

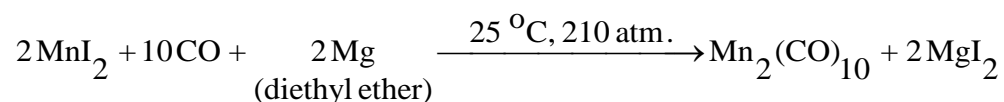

It can also be obtained by carbonylation of anhydrous manganese chloride with carbon monoxide in presence of sodium benzophenone ketyl.

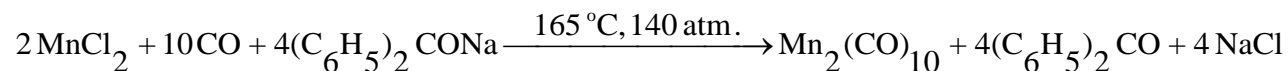
**Properties:**

It forms stable golden yellow crystals having melting point of 155 °C.

It is oxidized by trace amount of oxygen in solution. Hence, the solution must be stored in inert atmosphere.

Halogenation of dimanganese decacarbonyl proceeds with breaking of Mn-Mn bond and formation of carbonyl halides.

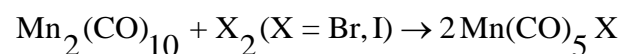

It reacts with sodium metal in liquid ammonia to give carbonylate anion.

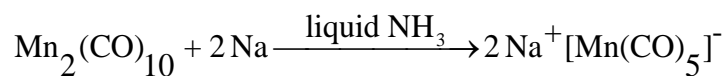

Structure:

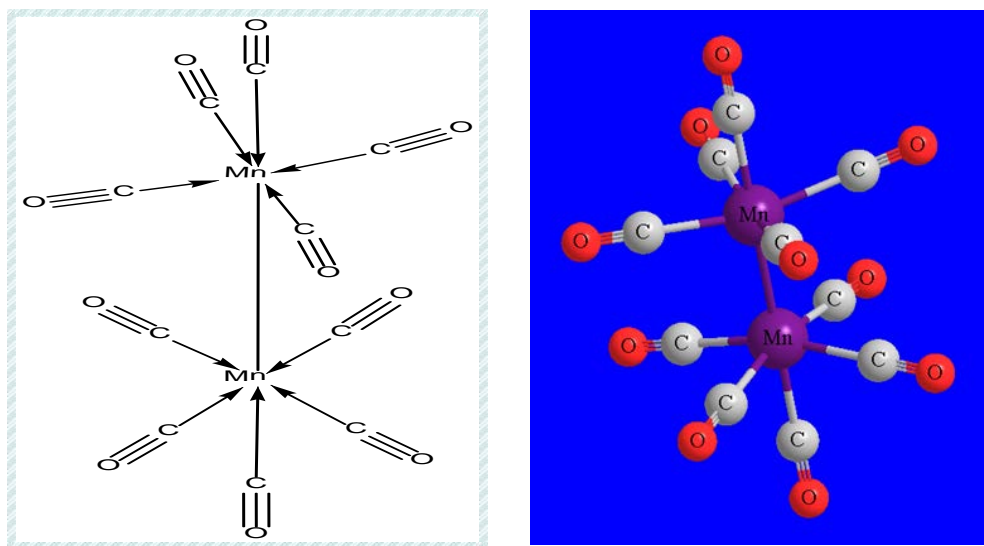

Figure: Structure of dimanganese decacarbonyl.

(View movie: [Mn2\(CO\)10 3D.flv](#) , [Mn2\(CO\)10 Red-Blue glasses.flv](#))

Manganese pentacarbonyl does not exist as Mn ($Z=25$) has an odd atomic number. However, the structure of dimanganese decacarbonyl consists of two manganese pentacarbonyl groups joined through a Mn-Mn (2.79 Å) bond. The formation of this inter metallic bond effectively adds one electron to each of the manganese atoms. Thus, manganese, an element with odd atomic number forms a binuclear carbonyl. Since the molecule does not have any unpaired electrons, it is

diamagnetic. The remaining two members of group VIIB viz. Technetium (Tc) and Rhenium (Re) also form decacarbonyls with similar structures.

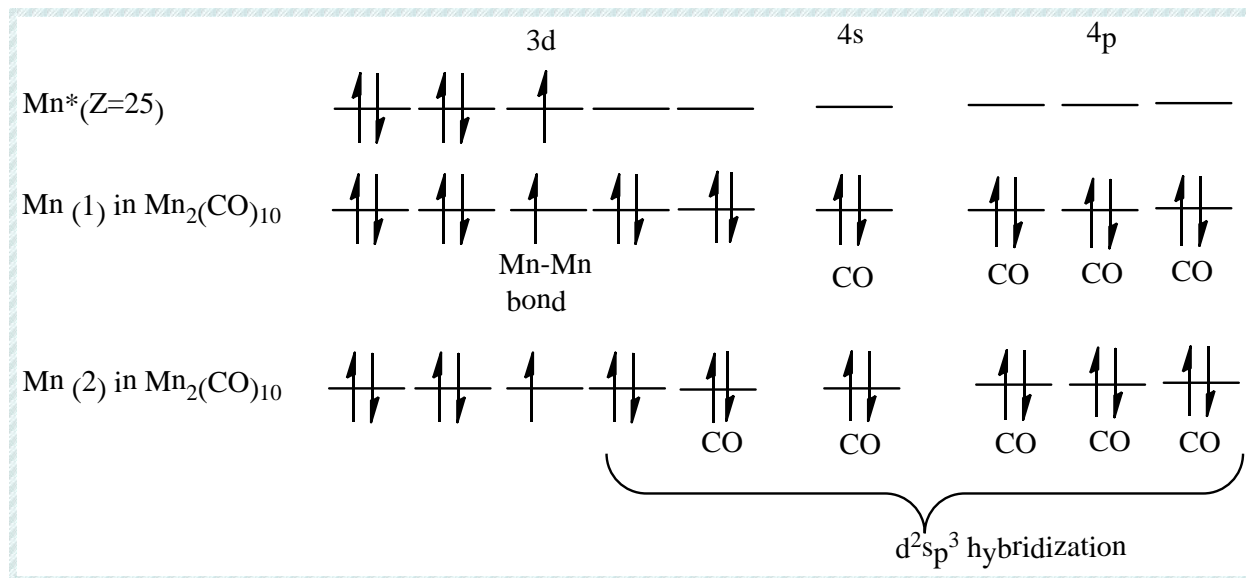
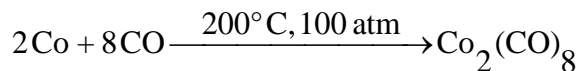

Figure: d^2sp^3 hybridization in dimanganese decacarbonyl.

$\text{Co}_2(\text{CO})_8$, Dicobalt octacarbonyl:

Preparation:

It can be prepared by direct combination of carbon monoxide with cobalt metal.



It can also be prepared by carbonylation of cobalt iodide/cobalt sulphide/cobalt carbonate using reducing agents like copper metal or hydrogen gas.

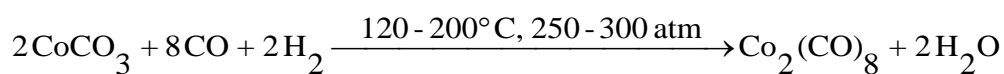
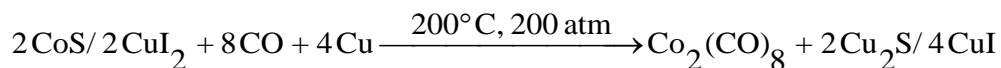

Properties:

It is an orange crystalline substance having melting point 51°C and turns deep violet upon exposure to air.

It is soluble in alcohols, ether and carbon tetrachloride.

Upon heating at 50 °C it forms tetracobalt dodecacarbonyl.

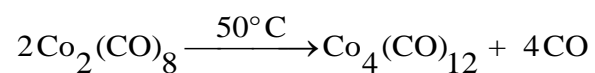

It reacts with nitric oxide to form cobalt carbonyl nitrosyl.



Structure:

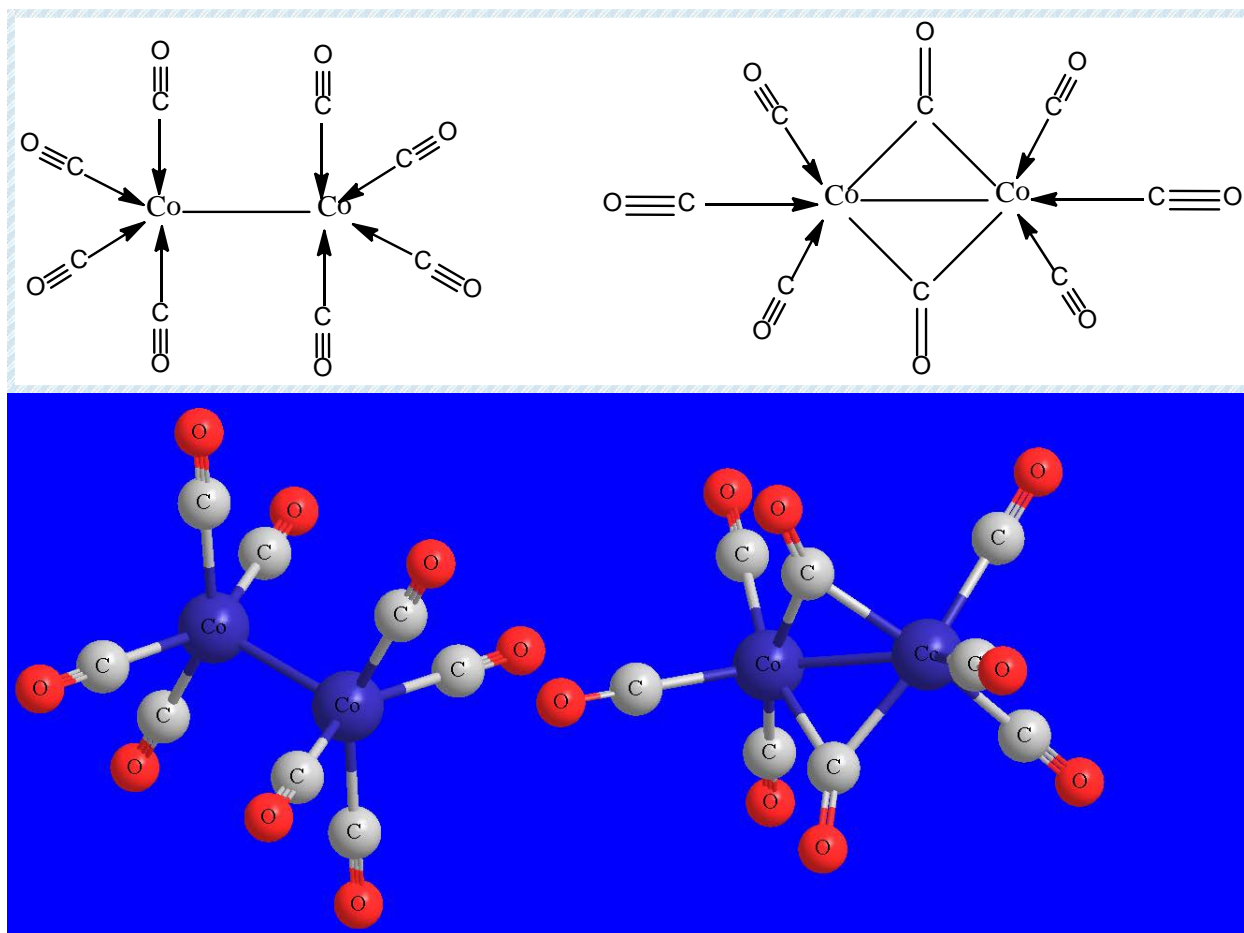

Figure: Structure of dicobalt octacarbonyl (without bridge and with bridge).

(View movie: [\(Co\)₂CO₈ 3D.flv](#), [\(Co\)₂CO₈ Red-Blue glasses.flv](#))

Dicobalt octacarbonyl is known to exist in two isomeric forms. A bridged structure of this molecule is observed in the solid state as well as solution state at a very low temperature. A non-bridged structure predominates in a solution at temperatures above ambience.

In the bridged structure, the cobalt atoms are in d^2sp^3 hybrid state. Three such hybrid orbitals on each cobalt atom accept lone pair of electrons from three carbon monoxide molecules to form total six Co←CO coordinate bonds. A Co-Co bond is formed by the overlapping of two half -

filled d^2sp^3 hybrid orbitals on the cobalt atoms. Remaining two half-filled hybrid orbitals on each Co atom overlap with appropriate orbital on carbon atom of the carbonyl to form two bridging CO groups. Thus, all electrons in this molecule are paired and it is diamagnetic.

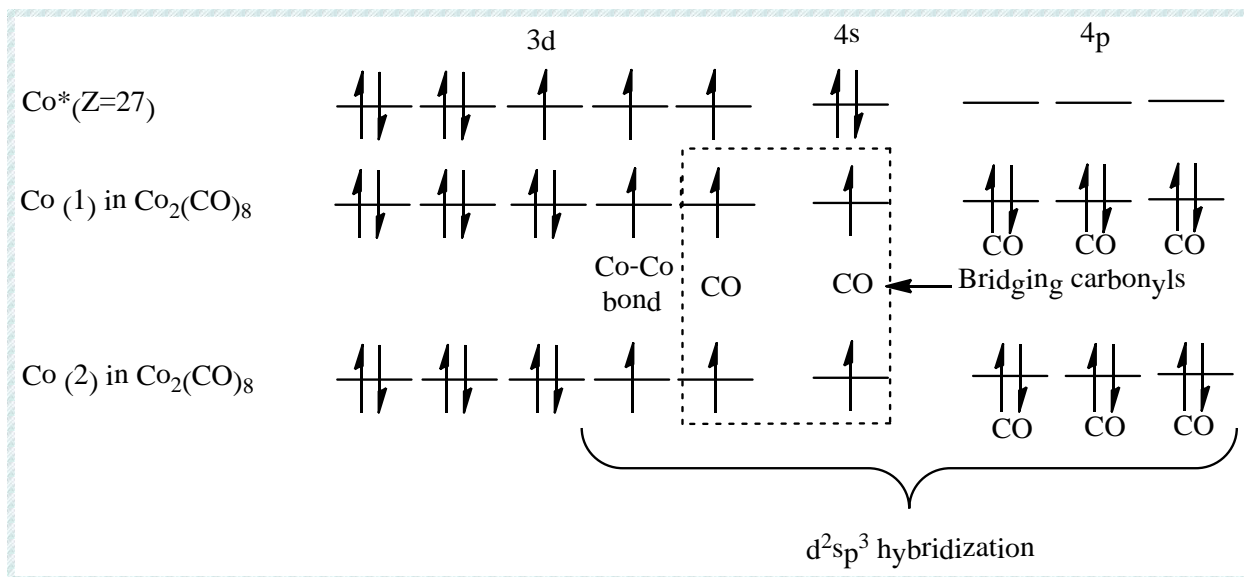

Figure: d^2sp^3 hybridization in dicobalt octacarbonyl

In the structure without bridge, the cobalt atoms are in dsp^3 hybrid state. Out of the five hybrid orbitals on each cobalt atom, four orbitals on each cobalt atom accept a lone pair of electrons from the carbon monoxide molecules to form eight $\text{Co} \leftarrow \text{CO}$ coordinate bonds. One half-filled orbitals on each cobalt overlap to form a Co-Co bond.

In case of non-bridge structure, Co atoms have dsp^3 hybridization as shown below.

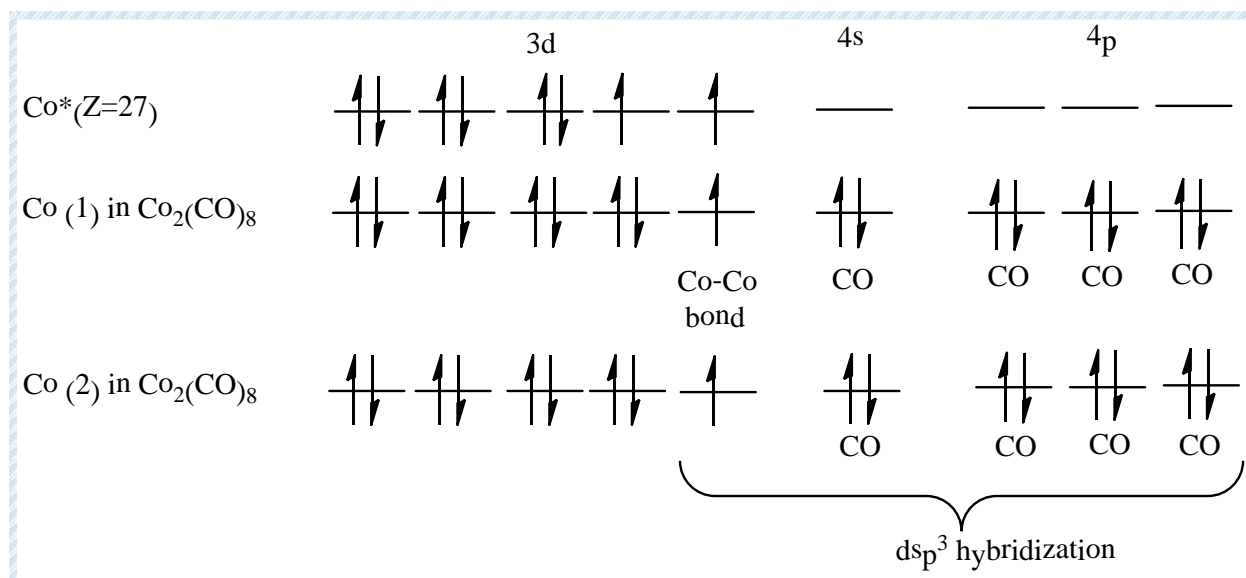
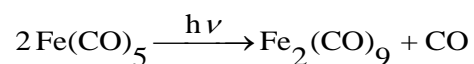

Figure: dsp^3 hybridization in dicobalt octacarbonyl

$Fe_2(CO)_9$, Diiron nonacarbonyl:

Preparation:

Cold solution of iron pentacarbonyl in glacial acetic acid undergoes dimerization under the influence of ultra-violet light to give golden yellow crystals.



Properties:

Diiron nonacarbonyl forms golden yellow triclinic crystals melting at 100 °C.

It is insoluble in water but soluble in toluene and pyridine.

A solution of diiron nonacarbonyl in toluene disproportionates when heated to 70 °C.

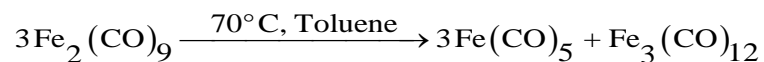

Diiron nonacarbonyl reacts with sodium metal in liquid ammonia to give carbonylate anion.

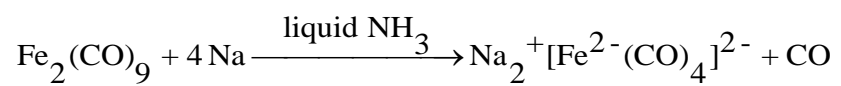

Structure:

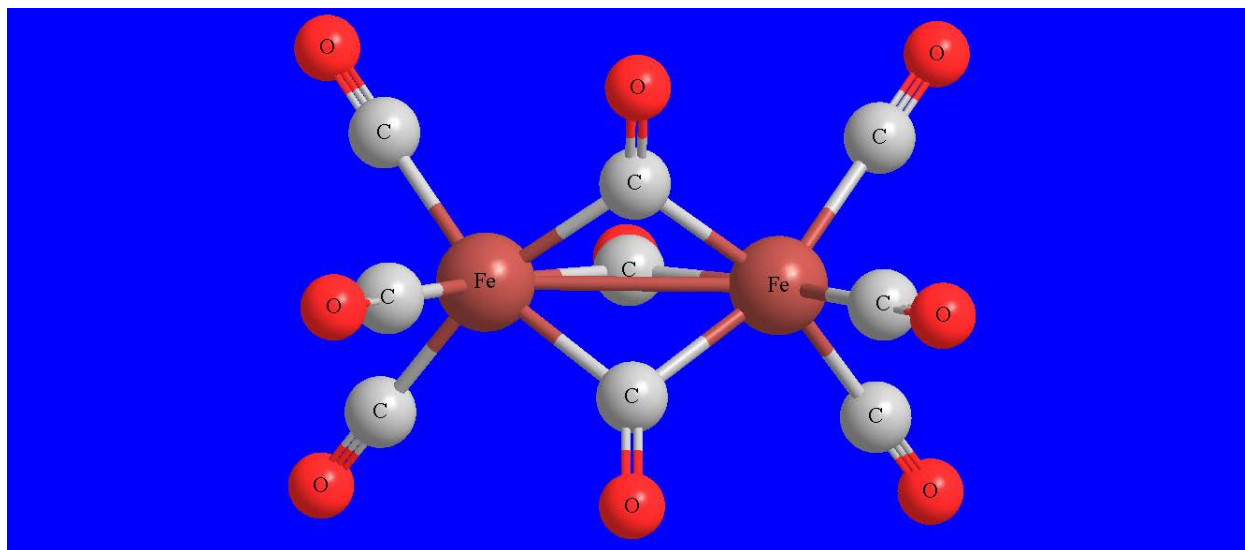
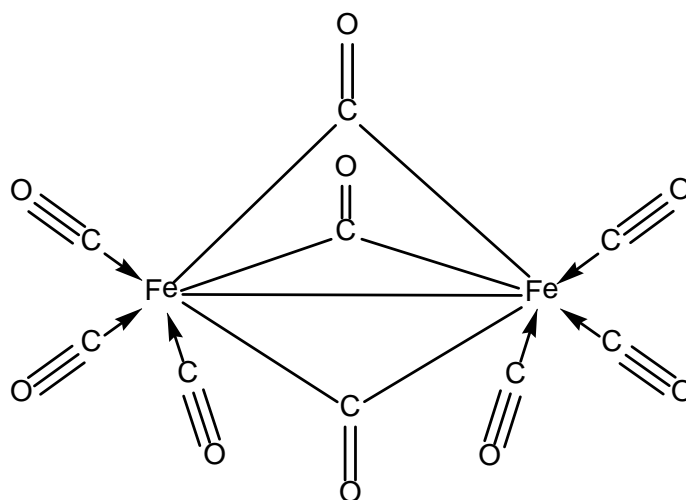

Figure: Structure of diiron nonacarbonyl.

(View movie: [Fe2\(CO\)9 3D.flv](#) , [Fe2\(CO\)9 Red-Blue glasses.flv](#))

Each of the iron atoms in diiron nonacarbonyl has three terminal carbonyl groups. The remaining three carbon monoxide ligands act as μ_2 -CO groups. In addition to this, there is a weak Fe-Fe bond (2.46 Å) formed by sharing of two unpaired electrons present in the 3d orbitals of iron atoms. Thus, both the iron atoms in the molecule are identical with coordination number seven. Since the molecule does not have any unpaired electron, it is diamagnetic.

The structure of this molecule can be explained using d^2sp^3 hybridization in Fe atoms as shown in the figure.

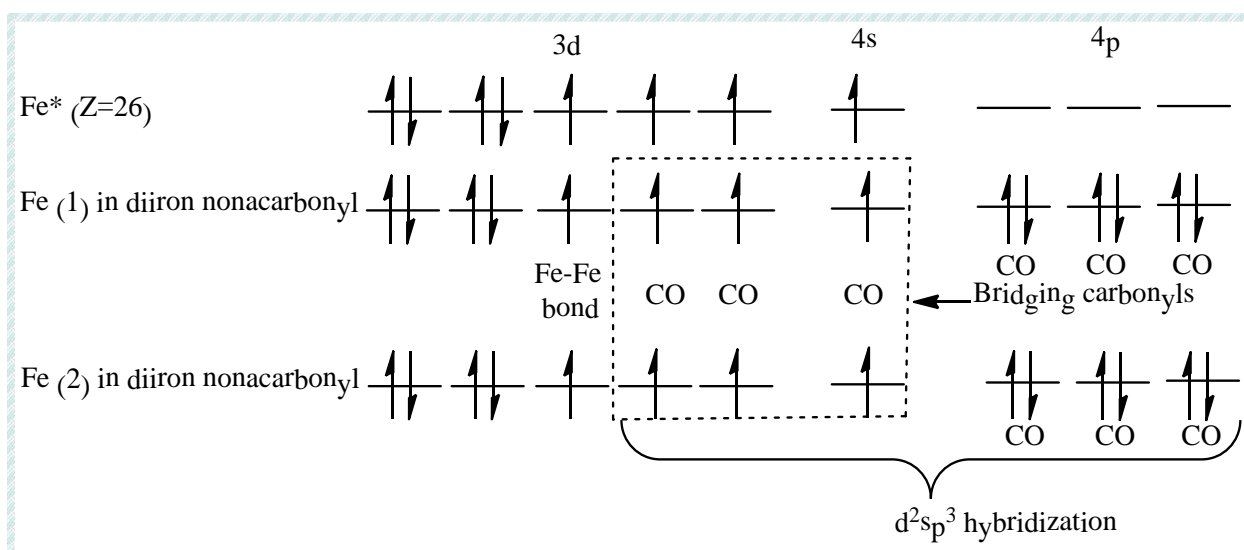
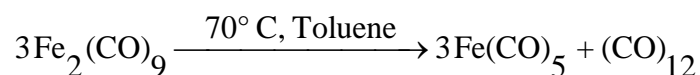

Figure: d^2sp^3 hybridization in diiron nonacarbonyl

LECTURE #7**Fe₃(CO)₁₂, Triiron dodecacarbonyl:****Preparation:**

It is prepared by heating diiron nonacarbonyl dissolved in toluene at 70 °C.

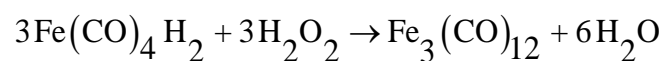
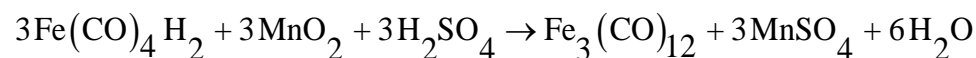

It can also be prepared by oxidation of iron carbonyl hydride.

**Properties:**

It forms green monoclinic crystals which are soluble in organic solvents like toluene, alcohol etc.

It decomposes at 140 °C to give metallic iron and carbon monoxide.

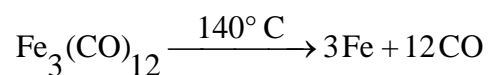

It gives substitution reaction with pyridine and methanol.

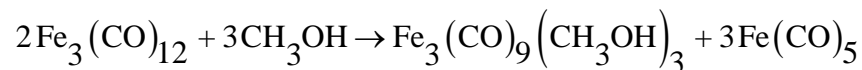
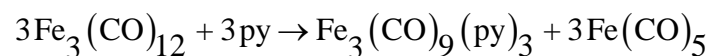

It reacts with sodium metal in ammonia to give carbonylate anion.

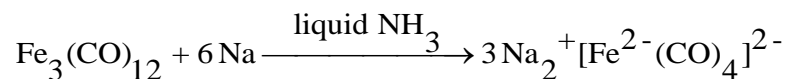

It reacts with nitric oxide to form iron dicarbonyl dinitrosyl

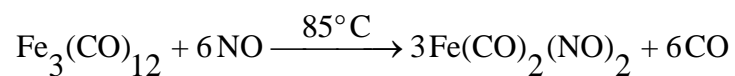
**Structure:**

Triiron dodecacarbonyl has a 3-membered ring structure. Two iron atoms in this molecule have three terminal carbonyl groups while the third iron atom is connected to four terminal carbonyls. Two $\mu\text{-CO}$ groups also connect the former iron atoms. In addition to this, there are three Fe-Fe bonds (2.8 Å) connecting each of the iron atoms.

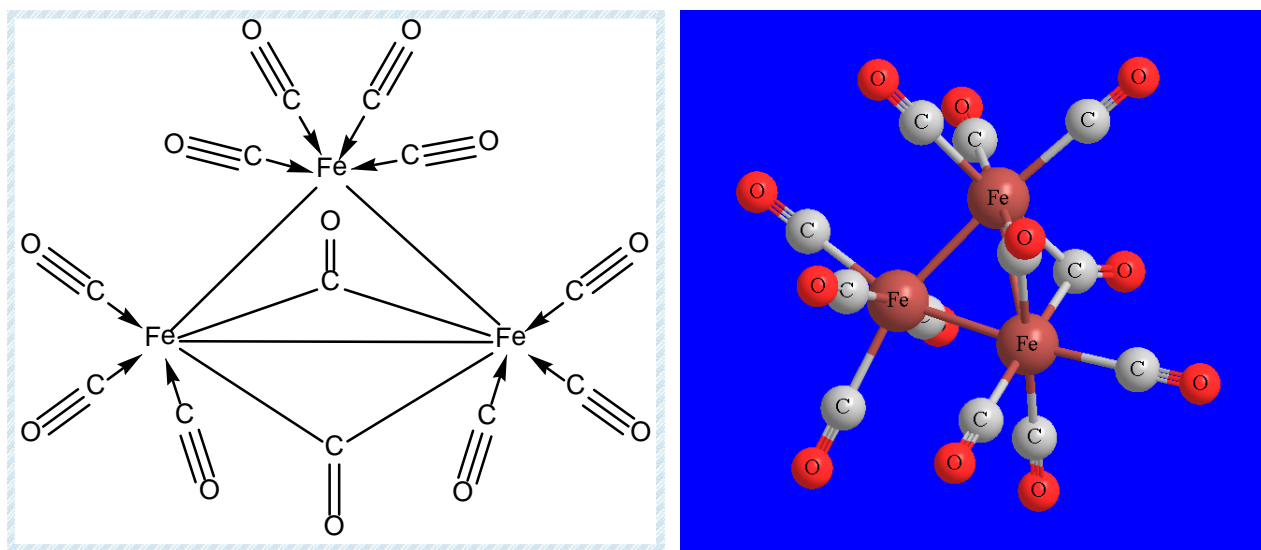

Figure: Structure of triiron dodecacarbonyl.

(View movie: [Fe3\(CO\)12 3D.fly](#) , [Fe3\(CO\)12 Red-Blue glasses.fly](#))

9. STRUCTURES OF FEW POLYNUCLEAR CARBONYLS:

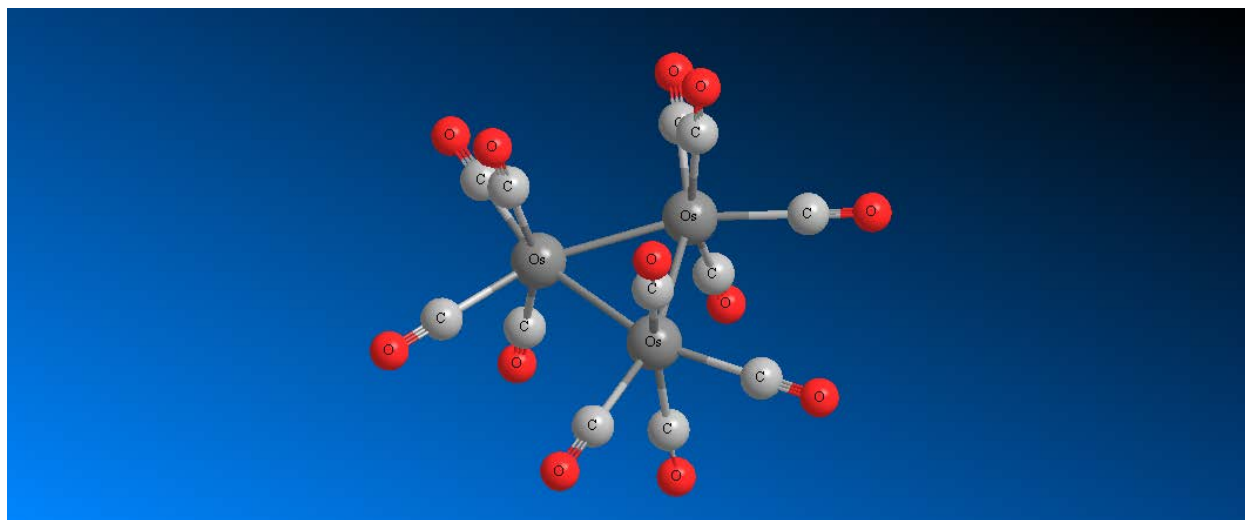

Figure: Structure of triosmium dodecacarbonyl.

View movie: [Os₃\(CO\)₁₂ 3D.flv](#), [Os₃\(CO\)₁₂ Red-Blue glasses.flv](#)

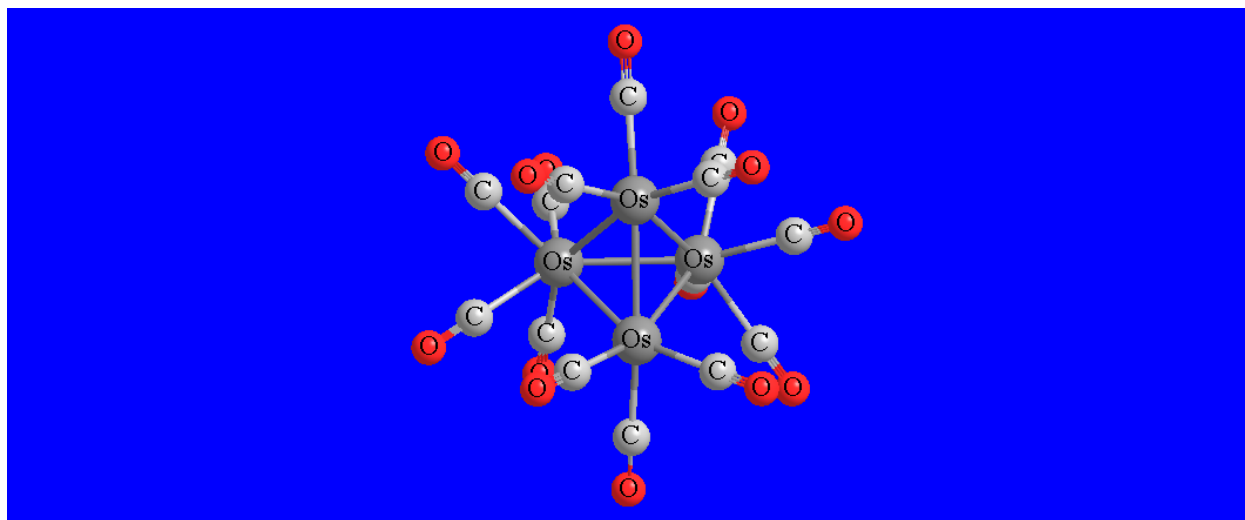

Figure: Structure of tetraosmium dodecacarbonyl.

View movie: [Os4\(CO\)14 3D.flv](#), [Os4\(CO\)14 3D Red-Blue glasses.flv](#)

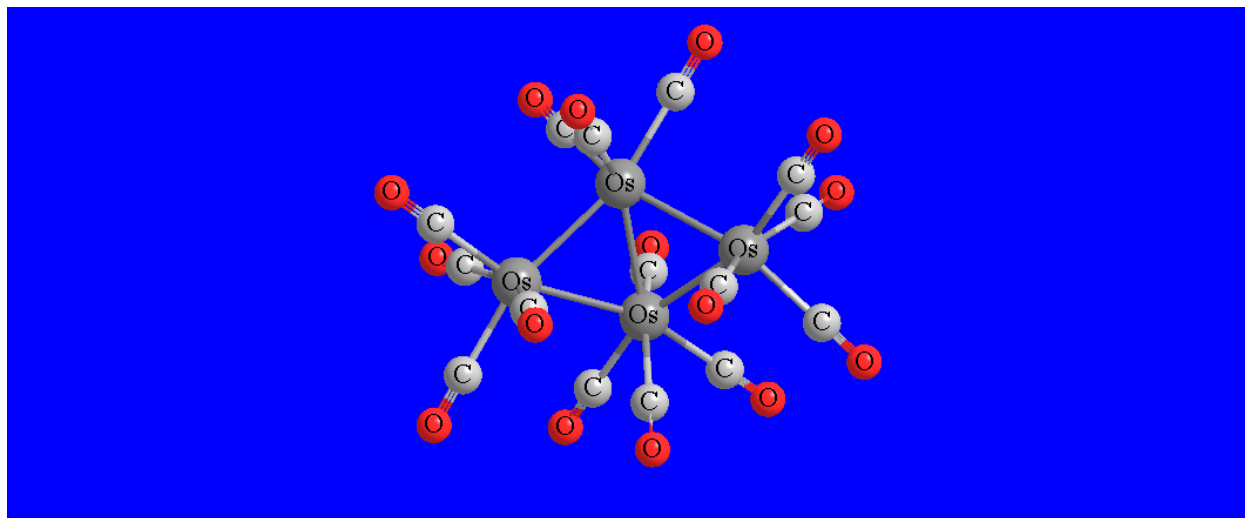

Figure: Structure of tetraosmium pentadecacarbonyl.

View movie: [Os4\(CO\)15 3D.flv](#), [Os4\(CO\)15 Red-Blue glasses.flv](#)

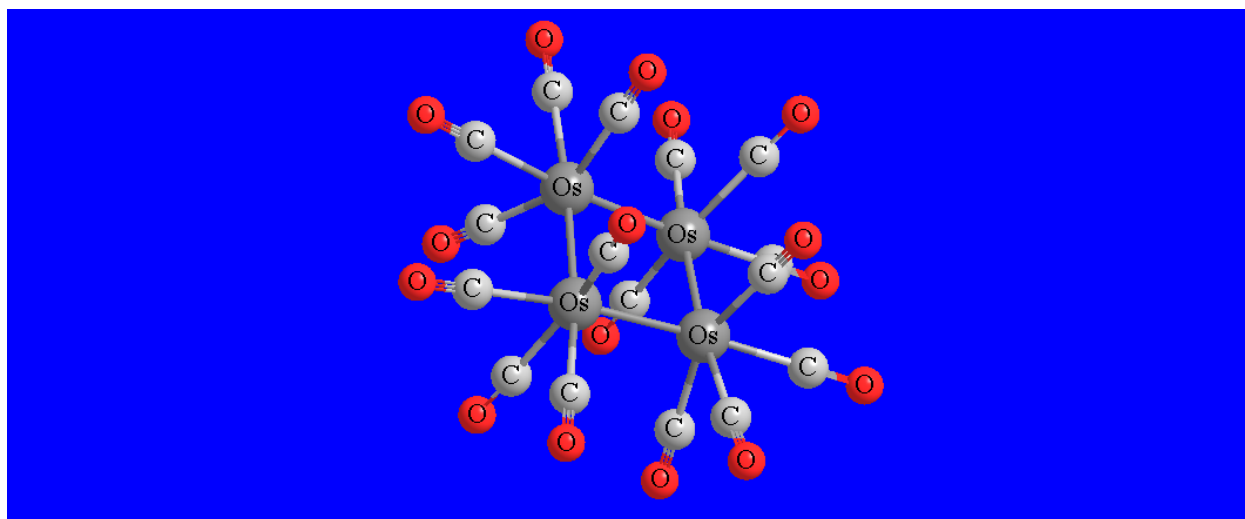

Figure: Structure of tetraosmium hexadecacarbonyl.

View movie: [Os₄\(CO\)₁₆ 3D.flv](#), [Os₄\(CO\)₁₆ Red-Blue glasses.flv](#)

LECTURE #8

10. EFFECTIVE ATOMIC NUMBER (EAN) RULE:

Effective Atomic Number (EAN) is the total number of electrons surrounding the nucleus of a metal in a complex.

Sidgwick's EAN rule / Inert gas rule:

“The EAN of the metal atom in a stable complex is equal to the atomic number of a noble gas found in the same period of the periodic table.”

Most of the organometallic compounds including carbonyls and nitrosyls obey the EAN rule.

It is mainly useful in predicting the number of ligands attached to the metal in such compounds.

Calculation of EAN:

An equation for calculating the EAN may be represented as follows:

$$\text{EAN} = Z + a + b + c$$

Where,

Z = Atomic number of metal atom

a = Number of electrons donated by terminal carbonyl groups

b = Number of electrons donated by bridging carbonyl groups

c = Number of electrons donated by other metal atom for the formation of M-M bonds

The EAN for nickel atom in nickel tetracarbonyl can be calculated as follows:

In nickel tetracarbonyl,

$$Z = \text{Atomic number of metal atom} = \text{Atomic number of nickel atom} = 28$$

a = Number of electrons donated by terminal carbonyl groups = 4 terminal carbonyl groups x 2 electrons donated by each group = 8

b = Number of electrons donated by bridging carbonyl groups = 0 (Because there are no bridge bonds)

c = Number of electrons donated by other metal atom for the formation of M-M bonds = 0 (Because there are no M-M bonds)

Thus,

$$\text{EAN} = Z + a + b + c = 28 + 8 + 0 + 0 = 36$$

Here, the effective atomic number is found to be 36 which is the atomic number of Krypton ($Z=36$) which is a noble gas lying in the same period of the periodic table as Ni ($Z=28$).

Thus, EAN rule is said to be obeyed in nickel tetra carbonyl.

In order to check the validity of the 18- electron rule, we have to put the number of valence electrons of the metal atom in place of atomic number (Z) in the EAN equation.

The valence shell nickel ($\text{Ni} = 3d^8 4s^2$) atom has 10 valence electrons.

Thus,

The number of valence electrons surrounding the nucleus of the metal atom

$$= \text{Number of valence electrons of metal atom} + a + b + c = 10 + 8 + 0 + 0 = 18$$

Thus, nickel tetracarbonyl obeys the 18 - electron rule.

The EAN for iron atoms in triiron dodecacarbonyl can be calculated as follows:

In triiron dodecacarbonyl, two iron atoms are bridged and have same environment while the third iron atom has a different bonding environment. Thus, we need to calculate the EAN for both the types of iron atoms separately.

For, bridged iron atoms

$$Z = \text{Atomic number of metal atom} = \text{Atomic number of iron atom} = 26$$

$$a = \text{Number of electrons donated by terminal carbonyl groups} = 3 \text{ terminal carbonyl groups} \times 2 \text{ electrons donated by each group} = 6$$

$$b = \text{Number of electrons donated by bridging carbonyl groups} = 2 \text{ bridging carbonyl groups} \times 1 \text{ electron donated by each group} = 2$$

$$c = \text{Number of electrons donated by other metal atom for the formation of M-M bonds} = 2 \text{ Fe-Fe bonds} \times 1 \text{ electron donated by each Fe atom} = 2$$

Thus,

$$\text{EAN} = Z + a + b + c = 26 + 6 + 2 + 2 = 36$$

Here, the effective atomic number is found to be 36 which is the atomic number of Krypton ($Z=36$) which is a noble gas lying in the same period of the periodic table as Fe ($Z=26$).

Thus, EAN rule is said to be obeyed by the bridging Fe atoms in triiron dodecacarbonyl.

In order to check the validity of the 18- electron rule, we have to put the number of valence electrons of the metal atom in place of atomic number (Z) in the EAN equation.

The valence shell nickel ($\text{Fe} = 3d^6 4s^2$) atom has eight valence electrons.

Thus,

The number of valence electrons surrounding the nucleus of the metal atom

$$= \text{Number of valence electrons of metal atom} + a + b + c = 8 + 6 + 2 + 2 = 18$$

Thus, the bridging Fe atoms in triiron dodecacarbonyl obey the 18 - electron rule.

For, un-bridged iron atom,

$$Z = \text{Atomic number of iron atom} = 26$$

$$a = 4 \text{ terminal carbonyl groups} \times 2 \text{ electrons donated by each group} = 8$$

$$b = 0 \text{ (Because no bridges are formed)}$$

$$c = 2 \text{ Fe-Fe bonds} \times 1 \text{ electron donated by each Fe atom} = 2$$

Thus,

$$\text{EAN} = Z + a + b + c = 26 + 8 + 0 + 2 = 36$$

Here, the effective atomic number is found to be 36 which is the atomic number of krypton (Z=36) which is a noble gas lying in the same period of the periodic table as Fe (Z=26).

Thus, EAN rule is said to be obeyed by the non-bridging Fe atom in triiron dodecacarbonyl.

In order to check the validity of the 18- electron rule, we have to put the number of valence electrons of the metal atom in place of atomic number (Z) in the EAN equation.

The valence shell of nickel ($\text{Fe} = 3d^6 4s^2$) atom has 8 valence electrons.

Thus,

The number of valence electrons surrounding the nucleus of the metal atom

$$= \text{Number of valence electrons of metal atom} + a + b + c = 8 + 6 + 2 + 2 = 18$$

Thus, the non-bridging Fe atom in triiron dodecacarbonyl obeys the 18 - electron rule.

Table: Calculation of effective atomic number (EAN) in some carbonyls

<i>Metal carbonyl</i>	<i>Z</i>	<i>a</i>	<i>b</i>	<i>c</i>	<i>EAN = Z + a + b + c</i>
<i>Ni(CO)₄</i>	28	4 x 2 = 8	0	0	36 [Kr]
<i>Fe(CO)₅</i>	26	5 x 2 = 10	0	0	36 [Kr]
<i>Ru(CO)₅</i>	44	5 x 2 = 10	0	0	54 [Xe]
<i>Os(CO)₅</i>	76	5 x 2 = 10	0	0	86 [Rn]
<i>Cr(CO)₆</i>	24	6 x 2 = 12	0	0	36 [Kr]
<i>Mo(CO)₆</i>	42	6 x 2 = 12	0	0	54 [Xe]
<i>W(CO)₆</i>	74	6 x 2 = 12	0	0	86 [Rn]
<i>Fe₂(CO)₉</i>	26	3 x 2 = 6	3 x 1 = 3	1 x 1 = 1	36 [Kr]
<i>Co₂(CO)₈</i> (bridged)	27	3 x 2 = 6	2 x 1 = 2	1 x 1 = 1	36 [Kr]
<i>Co₂(CO)₈</i> (without bridge)	27	4 x 2 = 8	0	1 x 1 = 1	36 [Kr]
<i>Mn₂(CO)₁₀</i>	25	5 x 2 = 10	0	1 x 1 = 1	36 [Kr]
<i>Fe₃(CO)₁₂</i>	26	4 x 2 = 8	0	2 x 1 = 2	36 [Kr]

*(for un
bridged Fe)*

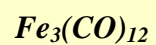

26

$3 \times 2 = 6$

$2 \times 1 = 2$ $2 \times 1 = 2$

36[Kr]

(for bridged

Fe)

LECTURE #9

While finding the EAN, if only valence electrons of the metal are considered, the resultant number for stable complexes comes out to be 18. Hence, the EAN rule is now referred to as Langmuir's 18-electron rule.

The octahedral complexes obeying the 18-electron rule (18-electron compounds) are especially stable. In order to understand this, consider the energy level diagram of an octahedral complex in presence of a strong field ligand.

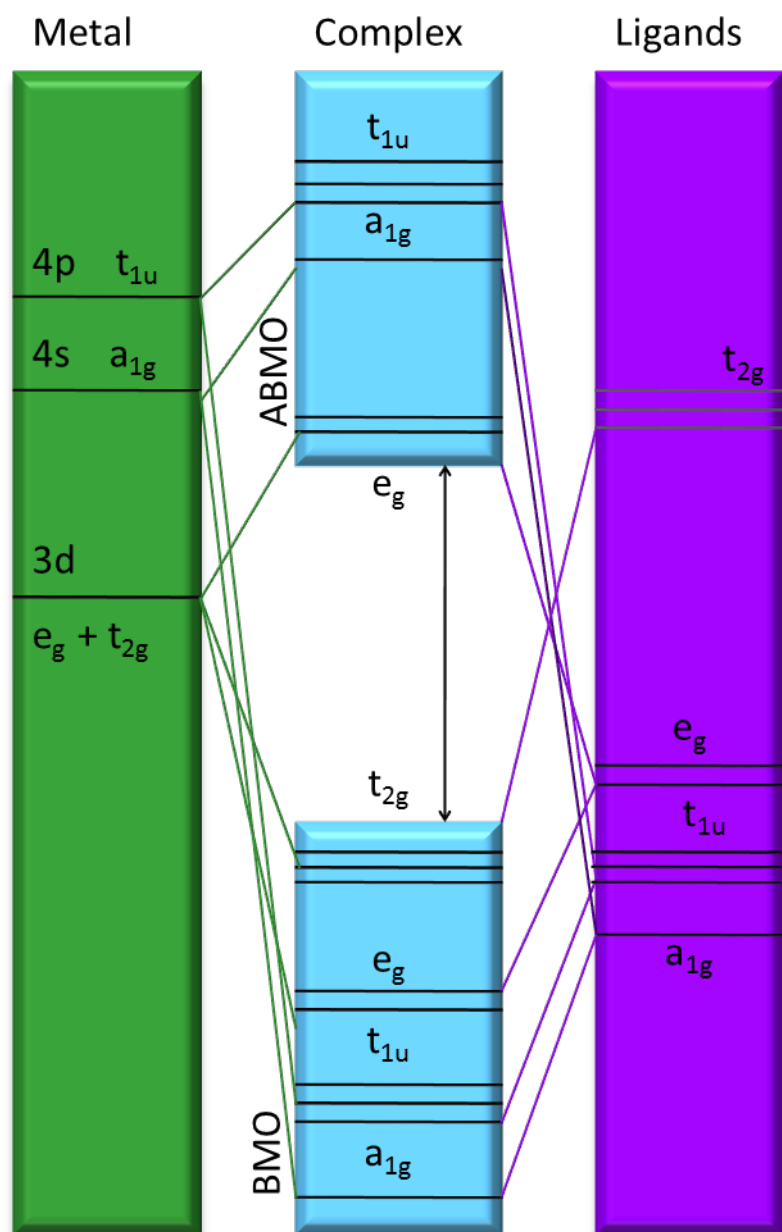

Figure: Energy level diagram of an octahedral complex in presence of strong field ligand.

Carbon monoxide is considered as a strong field ligand because despite its poor ability to donate σ -electrons, it has a remarkable ability to act as a π -acceptor. The symmetry adapted

combinations of six σ (a_{1g} , t_{1u} and e_g) and three π (t_{2g}) orbitals of the ligand are shown on the right hand side of the figure. The t_{2g} set of orbitals of the metal atom also act as bonding orbitals attributed to the presence of π interactions between the metal and ligand orbitals. In the MO diagram, there are nine bonding molecular orbitals. Thus, compounds containing all these BMOs filled with 18 electrons are very stable.

If more than 18 electrons are to be accommodated, the ABMOs must be filled. Such compounds are less stable and readily lose an electron showing the behaviour of reducing agents. Similarly, compounds with less than 18 electrons will have relatively low stability and tendency to react further in order to achieve 18 electron configurations.

Eight BMOs are present in a square planar complex in presence of strong field ligand. Thus, a 16-electron configuration is required for a stable square planar complex in presence of a strong field ligand. However, considering the donation of two electrons from each of the four ligands, only eight electrons can be managed from the ligand side. Due to this, the metal atom must provide additional eight electrons. This is possible only with the metal ions of group 9 (Co, Rh, Ir) and 10 (Ni, Pd, Pt) lying towards the right hand side of the d-block.

Most of the organometallic compounds including carbonyls and nitrosyls obey the EAN rule.

It is mainly useful in predicting the number of ligands attached to the metal in such compounds.

Electron counting methods:

There are two popular methods giving same results for the electron count. They are;

Neutral Ligand method (Covalent method)

Donor Pair method (Ionic method)

Neutral Ligand method:

In this method, all the ligands are treated as electrically neutral. It takes into account the number of electrons it can donate in its neutral state. The neutral ligands capable of donating two electrons are designated as L. The ligands like Cl^- which can donate one electron in their neutral state are designated as X type ligands. The ligand cyclopentadienyl ($\eta^5\text{-C}_5\text{H}_5$) which is a five-electron donor is designated by a combined symbol L_2X . This method is easy to use when the ligands are properly designated. The over emphasis on degree of covalence along with negligence of the charge over the metal ion remain shortcomings of this method. Due to this, it becomes difficult to assign oxidation states to the metal ion resulting in the loss of important information related to the ligands.

The verification of 18-electron rule for a mixed ligand carbonyl complex $(\eta^5\text{-C}_5\text{H}_5)\text{Fe}(\text{CO})_2\text{Cl}$ can be carried out as follows:

In this complex, the Fe atom has eight valence electrons.

In addition to this, the ligand $\eta^5\text{-C}_5\text{H}_5$ when considered as a neutral ligand contributes five electrons.

CO is two-electron donor, thus two CO ligands contribute 4 electrons.

Cl, counted as a neutral species is single electron donor, which contributes one electron in total.

Thus the total electron count can be shown as below:

One Fe atom	8 electrons
One (η^5 -C ₅ H ₅) ligand (L ₂ X)	5 electrons
Two CO ligands (L)	4 electrons
One chlorine ligand (X)	1 electron
Total electron count	18 electrons

An organometallic compound containing ligands designated by L and X can be shown as $[MX_aL_b]^c$, where a is the number of ligands of type X, b is the number of ligands of type L and c is the charge over the complex.

Electron Count = $n + a + 2b - c$, where n is the group number of the metal in periodic table.

$(\eta^5\text{-C}_5\text{H}_5)\text{Fe}(\text{CO})_2\text{Cl}$ can be represented as $[(L_2X)M(2L)(X)]$ or $[MX_2L_4]$

Electron Count = $n + a + 2b - c = 8 + 2 + 2 \times 4 - 0 = 18$

Donor Pair method:

According to this method, some ligands are treated as neutral whereas the others are treated as charged. It is assumed that the ligands donate electrons only as pairs. Neutral ligands like CO are considered as two electron donors. Ligands like halides are considered to take an electron from metal and treated as X. The ligand (η^5 -C₅H₅) is considered as C₅H₅⁻, which becomes a six-electron donor.

The oxidation state of the metal is calculated as total charge over the complex minus charges over the ligands. The number of electrons contributed by metal is calculated as the group number minus its oxidation number. Finally, the electron count is done as the total of electrons on the metal and the electrons contributed by the ligands.

A sample calculation for $(\eta^5\text{-C}_5\text{H}_5)\text{Fe}(\text{CO})_2\text{Cl}$ is provided below:

Here oxidation state of Fe, can be calculated as

$$-1 + X + 0 - 1 = 0$$

$$X = +2$$

The group number of Fe is 8.

Therefore, number of electrons contributed by Fe is $8 - 2 = 6$.

Number of electrons contributed by one $\text{C}_5\text{H}_5^- = 6$.

Number of electrons contributed by two CO = 4.

Number of electrons contributed by one $\text{Cl}^- = 2$

<i>Ligand</i>	<i>Neutral Ligand Method</i>	<i>Donor Pair Method</i>
<i>H</i>	1(X)	2(H-)
<i>F, Cl, Br, I</i>	1(X)	2(X-)
<i>CO</i>	2(L)	2
<i>($\eta^5\text{-C}_5\text{H}_5$)</i>	5(L ₂ X)	6(C ₅ H ₅ ⁻)

<i>NO (Linear)</i>	3	2 (NO ⁺)
<i>NO (Bent)</i>	1	2(NO ⁻)

LECTURE #10

CATALYTIC ACTIVITY OF METALLIC CARBONYLS

Organometallic compounds in general and metal carbonyls in particular are known to show catalytic activity.

Most of the homogeneous catalytic cycles involve five steps of reaction. Hence, it is imperative to understand these steps before studying the catalytic cycles involved in different syntheses.

These steps are listed below:

1. Coordination of ligand and its dissociation
2. Migratory insertions and β -eliminations
3. Nucleophilic attack on coordinated ligands
4. Oxidations and reductions
5. Oxidative additions and reductive eliminations

Coordination of ligand and its dissociation

An efficient catalytic cycle requires a facile entry and exit of the ligand. Both coordination and dissociation of ligand must occur with low activation free energy. Labile metal complexes are therefore essential in catalytic cycles. Coordinatively unsaturated complexes containing an open or weakly coordinated site are labile.

Square-planar 16-electron complexes are coordinatively unsaturated and are usually employed to catalyse the reactions of organic molecules. Catalytic systems involving ML_4 complexes of Pd (II), Pt (II), and Rh (I), like hydrogenation catalyst, $[RhCl(PPh_3)_3]$ are well known.

Migratory insertions and β -eliminations

The migration of alkyl ligand to an unsaturated ligand is shown in the reaction below. This reaction is an example of migratory insertion reaction.

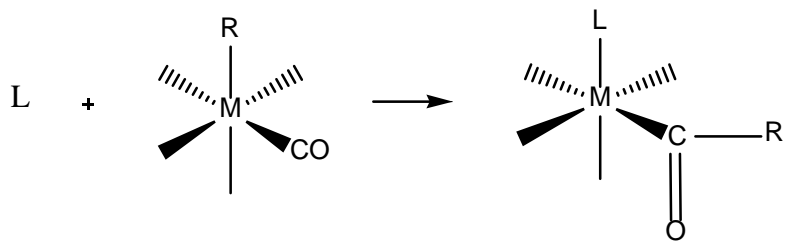

The migration of hydride ligand to a coordinated alkene to produce a coordinated alkyl ligand is shown in the reaction below.

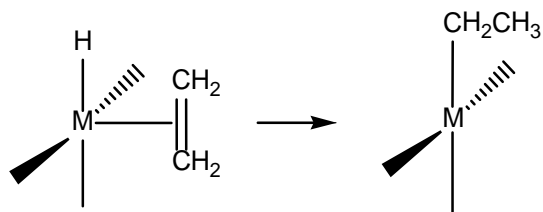

Elimination is the reverse of insertion. Elimination of β -hydrogen is illustrated in reaction shown below.

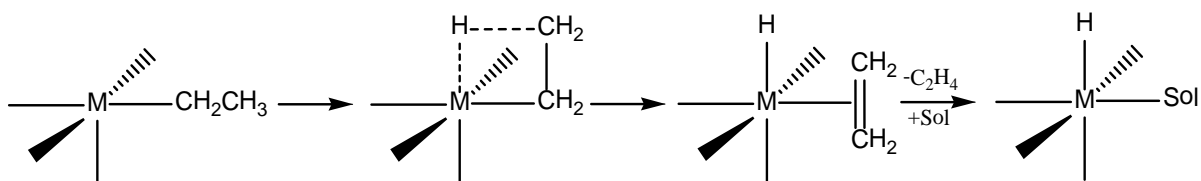

Nucleophilic attack on coordinated ligands

The coordination of ligands like as carbon monoxide and alkenes to metal ions in positive oxidation states activates the coordinated C atoms for a nucleophilic attack. These reactions have found special attention in catalysis as well as organometallic chemistry.

The hydration of coordinated ethylene with Pd (II) is an example of catalysis by nucleophilic activation. Stereochemical evidences indicate that the reaction occurs by direct attack on the most highly substituted carbon atom of the coordinated alkene:

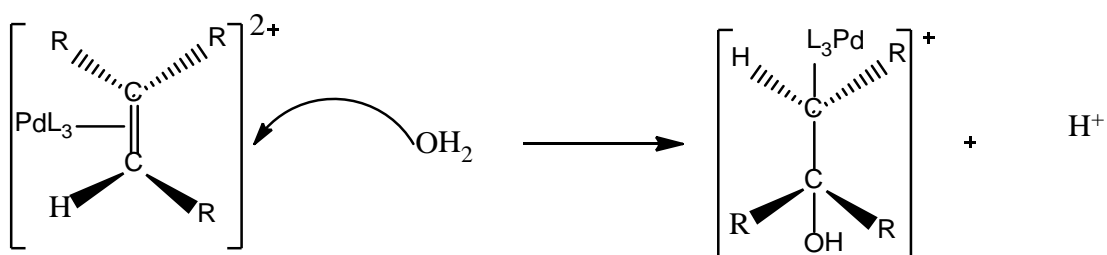

The hydroxylation of a coordinated alkene can also occur by the coordination of H₂O ligand to a metal complex followed by an insertion reaction as shown below:

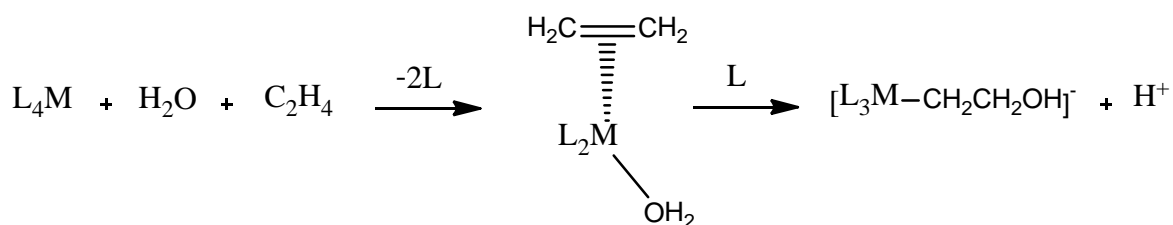

In a similar manner, a coordinated CO ligand undergoes a nucleophilic attack by an OH⁻ ion at the C atom, forming a -CO (OH) ligand, which subsequently loses CO₂ as shown below

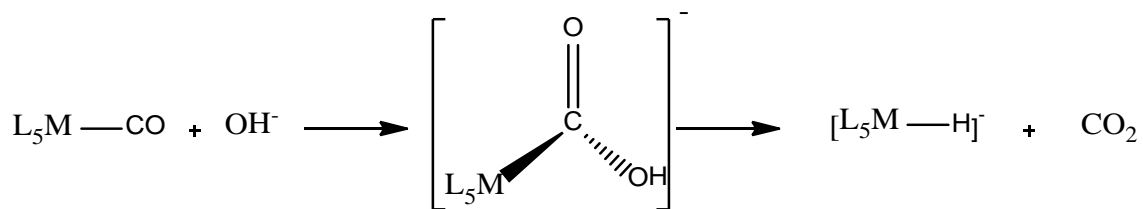

The water-gas shift reaction catalysed by metal carbonyl complexes or metal ions on solid surfaces involves this step.

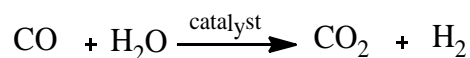

Oxidation and reduction

The use of metal complexes in the catalytic oxidation of organic compounds is popular. In these catalytic cycles, the metal atom shuttles between two oxidation states. Examples of common catalytic one-electron couples are $\text{Cu}^{2+}/\text{Cu}^+$, $\text{Co}^{3+}/\text{Co}^{2+}$, and $\text{Mn}^{3+}/\text{Mn}^{2+}$. An example of catalytic two-electron couple is Pd^{2+}/Pd .

Catalysts containing metal ions are also used in oxidation of hydrocarbons. The oxidation of p-xylene to terephthalic acid is an example of such use. The metal ions play different roles in these radical oxidations, as shown below:

Initiation ($\text{In}\cdot$ = Initiator radical):

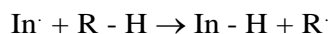

Propagation:

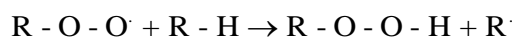
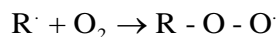

Termination:

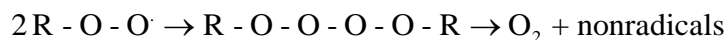
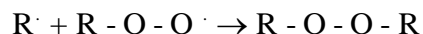
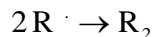

The metal ions control the reaction by contributing to the formation of the R–O–O· radicals:

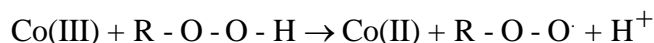

The metal atom shuttles back and forth between the two oxidation states in this pair of reactions.

A metal ion can also act as an initiator. For example, when arenes are involved it is thought that the initiation occurs by a simple redox process shown below:

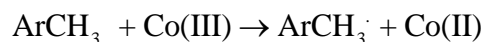

Oxidative addition and reductive elimination

The oxidative addition of a molecule AX to a complex occurs by the dissociation of the A–X bond followed by the coordination of two fragments as shown below:

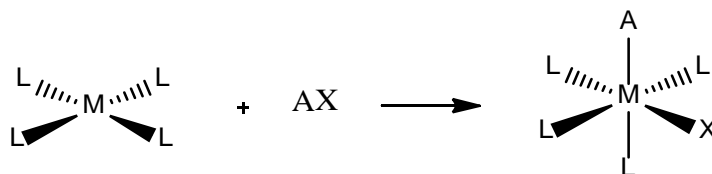

The reductive elimination is reverse of the oxidative addition, and generally follows it in a catalytic cycle.

The mechanisms of oxidative addition reactions are different. Depending upon reaction conditions and the nature of the reactants, there is evidence for oxidative addition by simple

concerted reaction, heterolytic (ionic) addition of A^+ and X^- , or radical addition of $A\cdot$ and $X\cdot$.

Even though, it has been observed that the rates of oxidative addition of alkyl halides generally follow the orders

Primary alkyl < secondary alkyl < tertiary alkyl

$F \ll Cl < Br < I$

LECTURE #11**Catalytic Hydrocarbonylation**

Dicobalt octacarbonyl is employed as a catalyst precursor in hydrocarbonylation of alkenes to produce aldehydes.

At 150 °C and 200 atmospheric pressure, the dicobalt octacarbonyl reacts with hydrogen to establish equilibrium with tetracarbonyl hydrido complex.

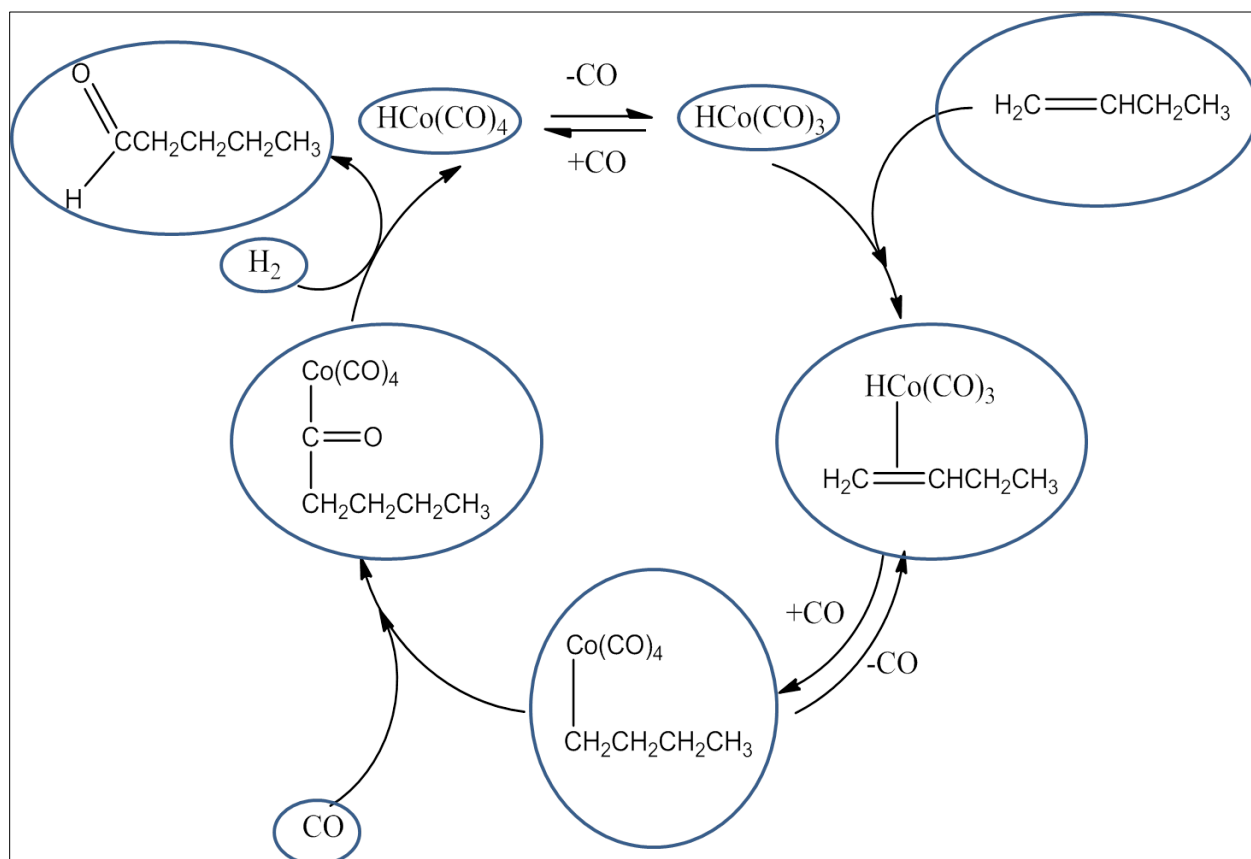
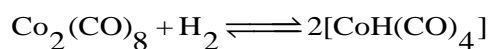
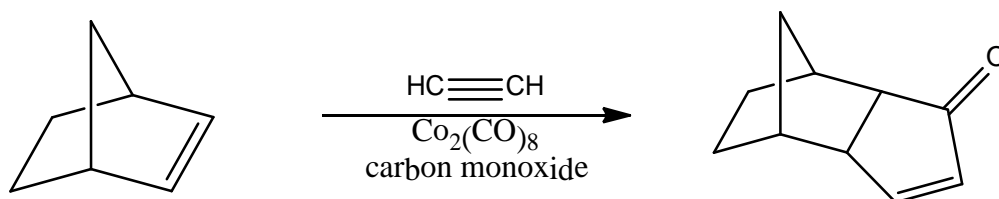

Figure: Catalytic cycle for hydrocarbonylation of 1-butene using cobalt carbonyl catalyst.

The hydrido complex loses a carbon monoxide ligand to initiate the catalytic cycle of hydrocarbonylation. The $\text{CoH}(\text{CO})_3$ thus produced coordinates an alkene to give $[\text{CoH}(\text{CO})_3(\text{CH}_2=\text{CHCH}_2\text{CH}_3)]$ which undergoes insertion reaction with the coordinated hydrido ligand and again coordinates the carbon monoxide ligand. The alkyl complex thus produced undergoes migratory insertion reaction and coordinates yet another carbon monoxide ligand to yield an acyl complex as shown in the above figure. The hydrocarbonylation occurs due to the attack by H_2 to give the product. The cycle continues due to regeneration of the catalyst at the end of the last step.

The Pauson –Khand Reaction



The dicobalt octacarbonyl catalysed three-component reaction of alkene, alkyne and carbon monoxide to give cyclopentenone is an important breakthrough in organic synthesis. A three component direct condensation to yield rings or fragments was very difficult earlier to the establishment of Pauson – Khand reaction.

Stirring a solution of bicyclo[2.2.1]hept-2-ene and dicobalt octacarbonyl in isooctane with acetylene gas at 60 – 70 °C followed passing a 1:1 gaseous mixture of acetylene and carbon monoxide yields the product (Endo 3a,4,5,6,7,7a-Hexahydro-4,7-methano-2-indene-1-one) shown in the reaction.

The general mechanism of these reactions involves the formation of cobalt complexes with acetylene followed by the insertion of alkene and carbonyl to give an acyl cobalt complex. This complex then undergoes a reductive elimination to produce cyclopentone.

Catalytic Carbonylation of Methanol

Monsanto acetic acid synthesis

Rhodium-catalysed carbonylation of methanol has become a very successful commercial process. This process for manufacture of acetic acid is popularly known as Monsanto process.

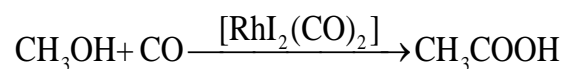

All three members of Group 9 (cobalt, rhodium, and iridium) catalyse the reaction shown above.

The complexes of the 4d metal; rhodium are found to be the most active. Earlier, a cobalt complex was used for this reaction, but the rhodium catalyst developed at Monsanto greatly reduced the cost of the process by allowing lower pressures to be used.

The catalytic cycle in the Monsanto process is shown in the figure below.

The cycle begins with the slowest step involving the oxidative addition of iodomethane to the four-coordinate, 16-electron complex $[\text{RhI}_2(\text{CO})_2]^-$ to give a six-coordinate 18-electron complex $[(\text{H}_3\text{C})\text{RhI}_3(\text{CO})_2]^-$ as shown in the catalytic cycle. The migratory insertion of carbon monoxide then yields a 16-electron acetyl complex $[\text{RhI}_3(\text{CO})(\text{COCH}_3)]^-$. The coordination of carbon monoxide restores an 18-electron complex which then undergoes reductive elimination of acetyl iodide generating $[\text{RhI}_2(\text{CO})_2]^-$. Finally, water hydrolyses the acetyl iodide to acetic acid and regenerates HI as:

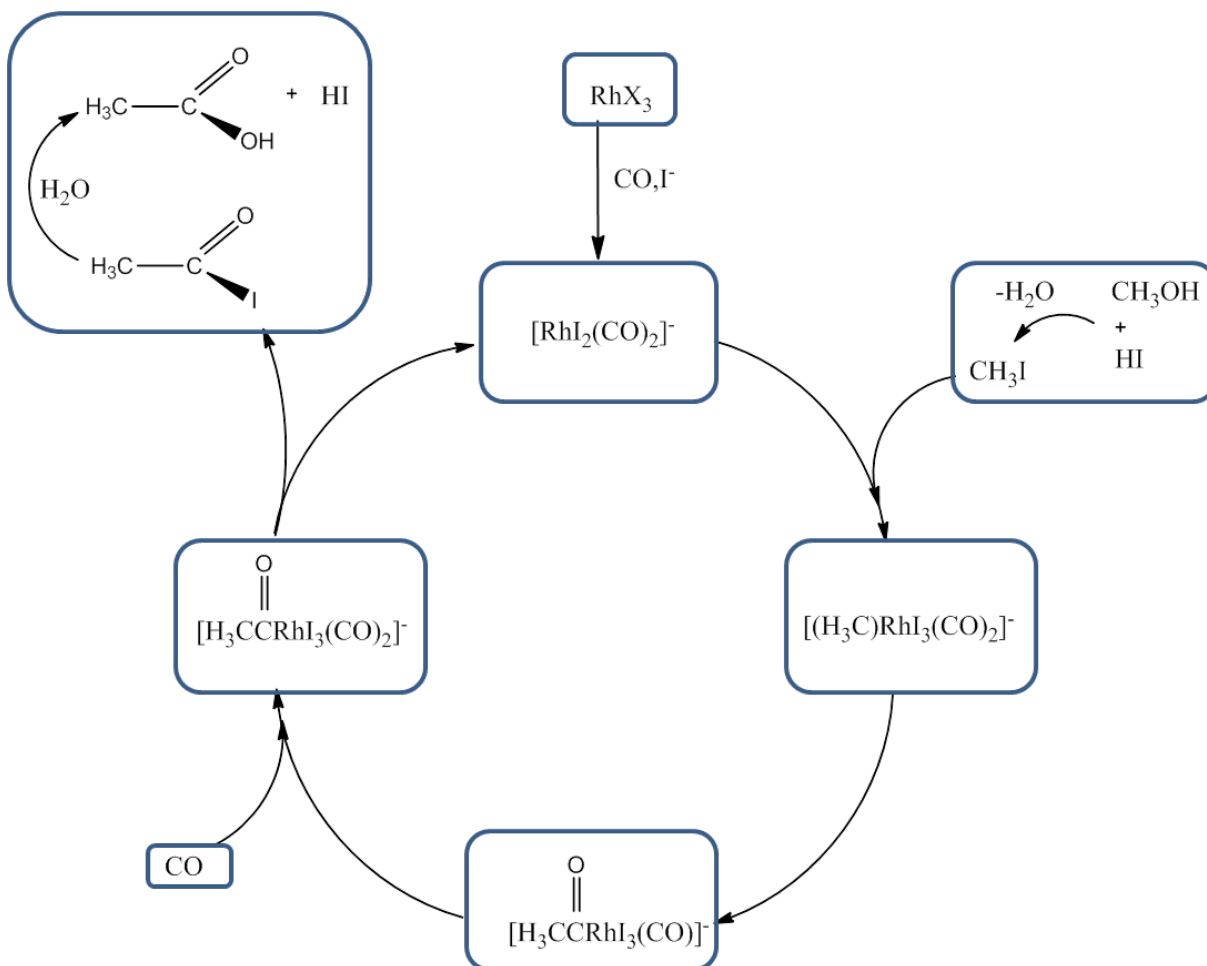
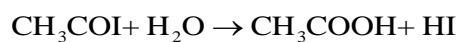

Iodide is the most suitable anion in this catalytic system as it undergoes the oxidative addition of iodomethane much faster than any other halo-alkanes. In addition to this, the soft I^- ion is a good ligand for the soft $\text{Rh}(\text{I})$ which probably forms a five-coordinate complex; $[\text{RhI}_3(\text{CO})_2]^{2-}$ which undergoes oxidative addition with iodomethane much faster than $[\text{RhI}_2(\text{CO})_2]^-$.

The strong acid HI is also effective in halogenating methanol:

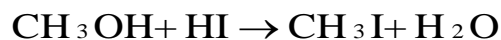

The Monsanto process has at least two drawbacks. The iodide moiety used in this process is corrosive. The rhodium complex used in the process is stable only under high pressures of carbon monoxide, which makes the recycling of the catalyst difficult.

EXERCISES

MULTIPLE CHOICE QUESTIONS

- Majority of metal carbonyls are _____
 (a) paramagnetic (b) diamagnetic (c) ferromagnetic (d) none of these
- Neutral carbonyl hydrides are _____
 (a) acidic (b) basic (c) neutral (d) amphoteric
- Anionic carbonyl hydrides are _____
 (a) acidic (b) basic (c) neutral (d) amphoteric
- Which of the following is used in Mond's process?
 (a) $\text{Ni}(\text{CO})_4$ (b) $\text{Co}_2(\text{CO})_8$ (c) $\text{Cr}(\text{CO})_6$ (d) $\text{Fe}(\text{CO})_5$
- The hybridization on Fe atom of $\text{Fe}(\text{CO})_5$ is?
 (a) dsp^3 (b) d^2sp^3 (c) sp^3d^2 (d) sp^3d
- How many nitrosyls are required to replace three carbonyl groups of a metal carbonyl?
 (a) 2 (b) 3 (c) 1 (d) 4
- Which catalyst is used in Pauson – Khand reaction?
 (a) $\text{Co}_2(\text{CO})_8$ (b) $\text{Fe}_3(\text{CO})_{12}$ (c) $\text{Fe}_2(\text{CO})_9$ (d) $\text{Mn}_2(\text{CO})_{10}$

8. Which one of the following catalyses Monsanto acetic acid synthesis?

- (a) $[\text{Rh}_4(\text{CO})_{16}]$ (b) $[\text{RhI}_2(\text{CO})_2]^-$ (c) $\text{Co}_2(\text{CO})_8$ (d) $\text{Fe}_3(\text{CO})_{12}$

SHORT / LONG ANSWER QUESTIONS

1. "Vanadium hexacarbonyl is paramagnetic": Explain
 2. Describe the Heiber base reaction.
 3. How is the C-O bond order related to the C-O stretching frequencies in metal carbonyls?
Explain.
 4. Calculate the EAN for $\text{V}(\text{CO})_6$.
 5. Explain the acidic and basic behaviour of carbonyl hydrides.
 6. How is the Collman's reagent prepared?
 7. Discuss the preparation, properties and structure of dicobalt octacarbonyl.
-

MODULE 2: METAL NITROSYLS

Key words: Nitric oxide; Roussin's salts; sodium nitroprusside; nitroso ferrous sulphate

MODULE 2: METAL NITROSYLS

LECTURE #12

1. INTRODUCTION

Roussin's red salt; $\text{Na}_2[\text{Fe}_2(\text{NO})_4\text{S}_2]$ and Roussin's black salt; $\text{Na}[\text{Fe}_4(\text{NO})_7\text{S}_3]$ were the earliest known metallic nitrosyls.

Metal nitrosyls are the transition metal complexes of nitric oxide (NO) containing metal-nitrogen bond.

Out of the five valence electrons, nitrogen utilizes two of them for the formation of a double bond with oxygen. The remaining three electrons remain on nitrogen as a lone pair and an odd electron.

2. BONDING IN METALLIC NITROSYLS:

Nitric oxide:

In order to understand the bonding in metallic nitrosyls, let us first see the MO diagram of nitric oxide (NO) molecule.

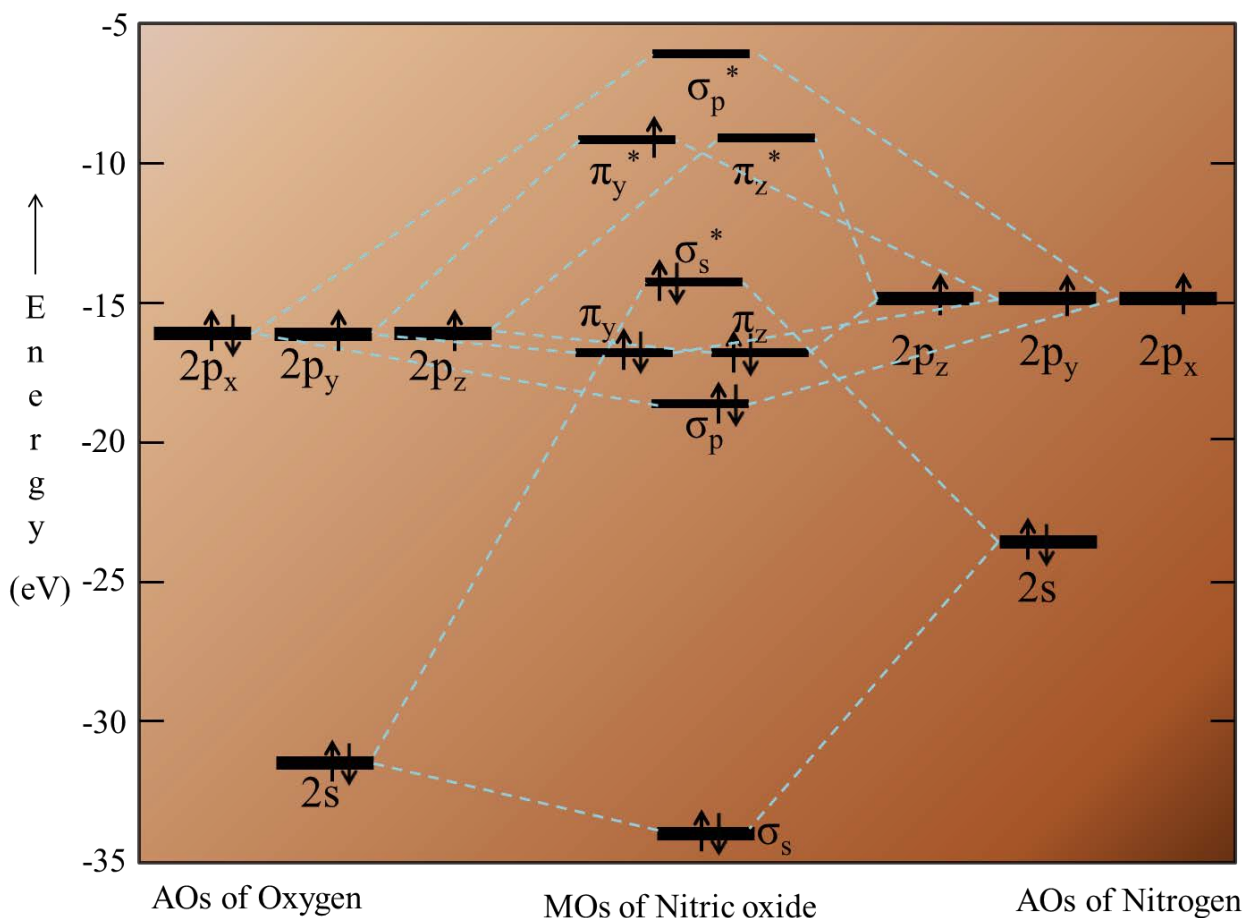
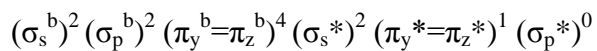

Figure: Molecular Orbital Energy Level Diagram of Nitric oxide

The order of energy of the molecular orbitals and the accommodation of eleven electrons of the nitric oxide can be shown as:



Following steps are involved during the formation of a linear metallic nitrosyl:

The odd electron on nitrogen of nitric oxide ($\pi_y^*=\pi_z^*$)¹ is lost to form nitrosyl cation wherein a lone pair of electron from oxygen is transferred to form the third bond between nitrogen and oxygen.

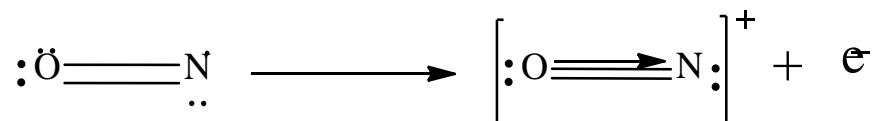

The odd electron ($\pi_y^*=\pi_z^*$)¹ is gained by the metal atom (M^0) which decreases its formal oxidation state (M) by one unit.



Nitrogen of the NO^+ (nitrosyl or nitrosonium ion) donates an electron pair to the metal ion (M) for coordination.

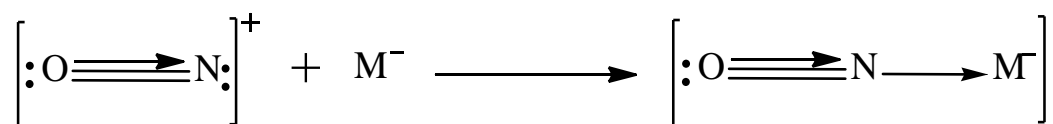

Majority of the nitrosyl complexes contain NO^+ (nitrosyl or nitrosonium ion) as the ligand. The nitrosyl cation is isoelectronic with carbon monoxide. Hence, the bonding between nitrogen and metal in nitrosyls is analogous to that of carbon and metal in carbonyls. However, the ligand nitrosyl (NO^+) is a three electron donor as it donates one electron to the metal ion prior to the donation of an electron pair for the formation of coordinate covalent bond.

Formation of dative σ -bond:

The overlapping of empty hybrid orbital (a blend of d, s and p orbitals) of metal atom with the filled hybrid orbital (HOMO) on nitrogen atom of (NO^+) ion results into the formation of a $\text{M} \leftarrow \text{NO}^+$ σ -bond.



Figure: Formation of a $\text{M} \leftarrow \text{NO}^+$ σ -bond in metal nitrosyls.

Formation of π -bond by back donation:

This bond is formed as a result of overlapping of filled $d\pi$ orbitals or hybrid $dp\pi$ orbitals of metal atom with low-lying empty (LUMO) orbitals on NO^+ ion. i.e. $\text{M} \xrightarrow{\pi} \text{NO}^+$

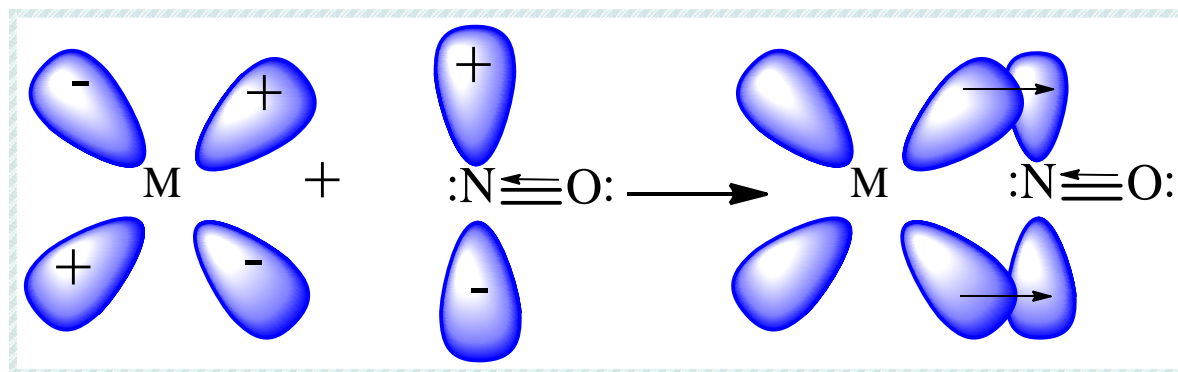

Figure: Formation of $\text{M} \xrightarrow{\pi} \text{NO}^+$ bond by back donation in metal nitrosyls.

From the M O diagram of nitric oxide molecule, we can see that σ_s^* is the highest occupied molecular orbital (HOMO) after loss of one electron. This orbital can donate the lone pair of electrons for the formation of a $\text{ON} \rightarrow \text{M}$ σ bond.

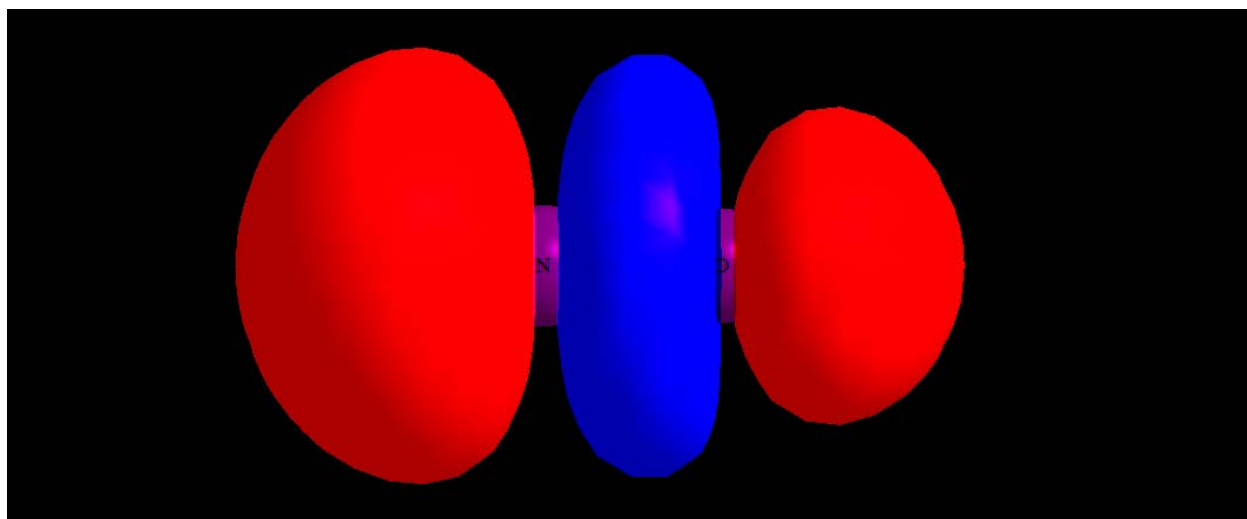

Figure: Highest occupied molecular orbital (HOMO) of nitrosyl ion.

(N.B: Red colour is for positive sign of the wave function while the blue colour indicates negative sign of the wave function)

Whereas ($\pi_y^*=\pi_z^*$) are the lowest unoccupied molecular orbitals(LUMO) which can accept the electron density from an appropriately oriented filled metal orbital resulting into formation of a $M \rightarrow NO^+ \pi$ bond.

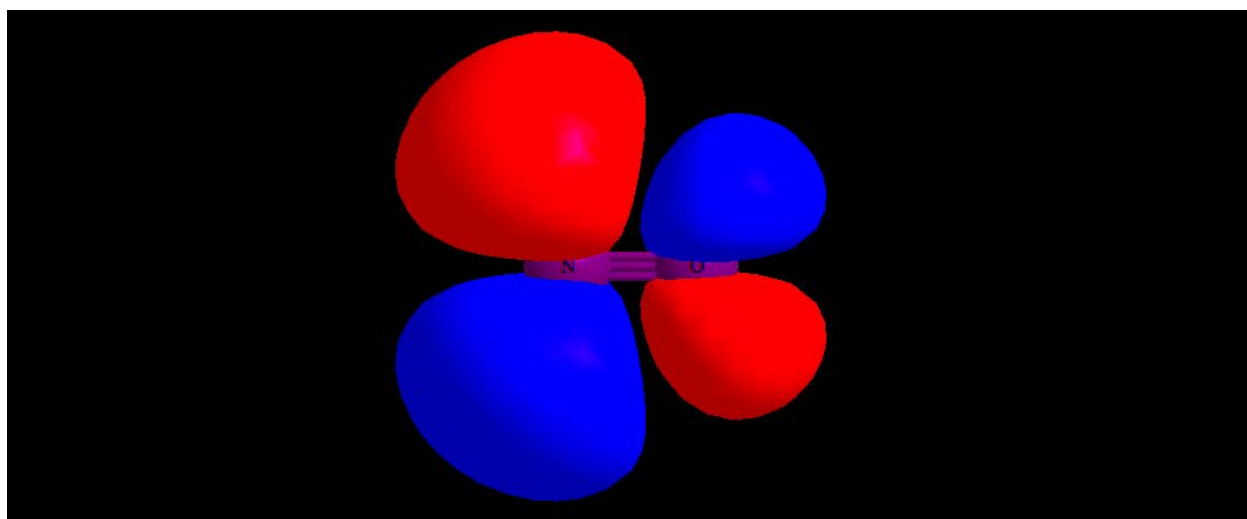

Figure: Lowest unoccupied molecular orbital (LUMO) of nitrosyl ion.

(N.B: Red colour is for positive sign of the wave function while the blue colour indicates negative sign of the wave function)

In certain nitrosyls like $[\text{Co}^{+3}(\text{CN})_5(\text{NO})]^{-3}$ and $[\text{Co}^{+3}(\text{NH}_3)_5(\text{NO})]^{+2}$ the nitric oxide is known to exist as nitric oxide anion (NO^-).

The following steps are involved during the formation of a metallic nitrosyl with nitric oxide anion (NO^-):

The nitrogen of nitric oxide gains one electron from metal atom / ion to form nitric oxide anion (NO^-). Nitrogen of the nitric oxide anion (NO^-) donates an electron pair to the metal for coordination.

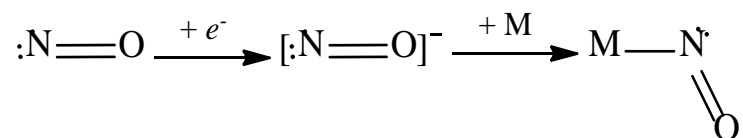

The nitrogen atom of the ligand in this case retains one lone pair. Because of this reason, the metallic nitrosyls containing nitric oxide anion (NO^-) are bent with M-N-O bond angle in the range of $120-140^\circ$. In these types of complexes, the nitric oxide effectively donates only one electron to the metal ion. Hence, NO^- can be considered as one electron donor.

LECTURE #13**3. INFRARED SPECTROSCOPY**

The free nitric oxide has a stretching frequency of 1870 cm^{-1} . A change in this frequency is expected upon ligation. Some of the factors that affect this change are the nature of co-ligands, charge on the complex and structure of the complex. We have already seen that the nitrosyl ligand is linear ($\angle\text{M-N-O}=180^\circ$) when it coordinates as NO^+ . The N-O stretching frequency in such complexes is observed in a broad range of $1950\text{--}1450\text{ cm}^{-1}$. The nitrosyl ligand is bent when it coordinates as NO^- . The angle M-N-O in such cases has been observed in the range of 120° to 140° . The observed N-O stretching frequency in such complexes is found to be slightly lower in the range of $1720\text{--}1400\text{ cm}^{-1}$.

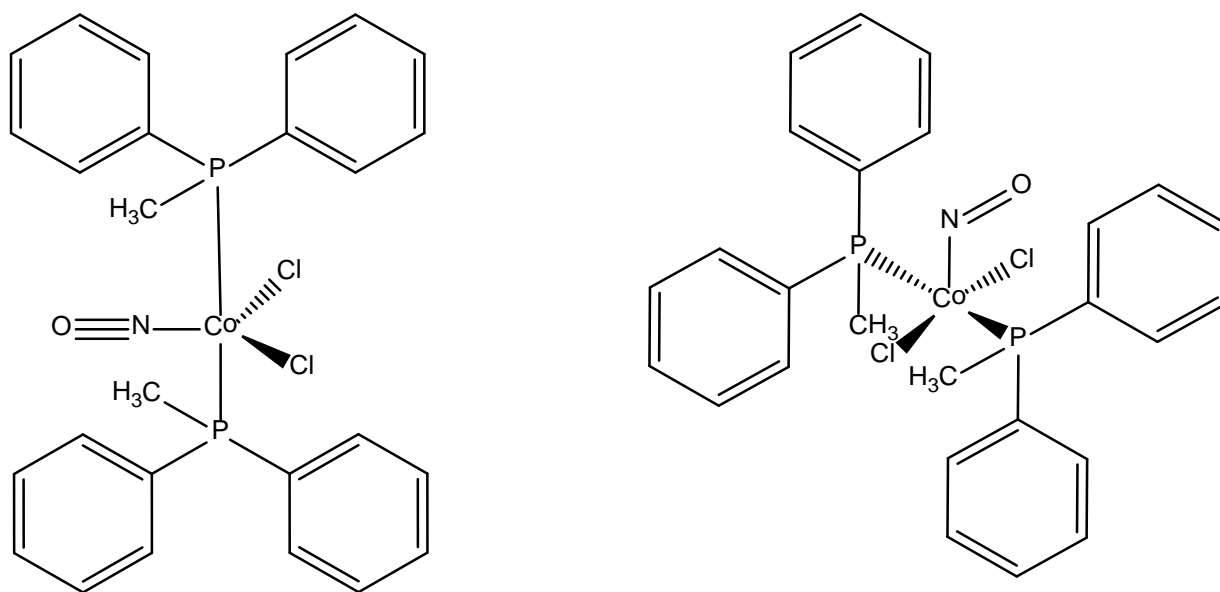

Figure: Structure of two isomeric forms of $[\text{CoCl}_2(\text{NO})(\text{PCH}_3\text{Ph}_2)_2]$

A five coordinated complex $[\text{CoCl}_2(\text{NO})(\text{PCH}_3\text{Ph}_2)_2]$ shown in the above figure is known to exist in two isomeric forms. The trigonal bipyramidal isomer exhibits N–O stretching frequency at 1750 cm^{-1} while the square pyramidal isomer absorbs at 1650 cm^{-1} . The bond angle and nitrosyl stretching frequencies of some mononuclear nitrosyl complexes of first transition series is shown in the table below.

Table: Comparison N-O stretching in some mononuclear metallic nitrosyls.

<i>Nitrosyl</i>	<i>Type</i>	$\angle M - N - O$	$\nu_{N-O} (\text{cm}^{-1})$
<i>Nitric Oxide</i>	Free	Not applicable	1870
$[\text{Fe}(\text{CN})_5\text{NO}]^{2-}$	Cyano nitrosyl	~175	1940
$[\text{Mn}(\text{CN})_5\text{NO}]^{3-}$	Cyano nitrosyl	~175	1725
$[\text{Cr}(\text{CN})_5\text{NO}]^{4-}$	Cyano nitrosyl	~175	1515
$[\text{V}(\text{CN})_5\text{NO}]^{-1}$	Cyano nitrosyl	~175	1530
$[\text{Coen}_2\text{Cl}(\text{NO})]^{+1}$	Nitric oxide as NO^-	121	1611
$[\text{Co}(\text{NH}_3)_5(\text{NO})]^{+2}$	Nitric oxide as NO^-	119	1610

There is a significant overlapping in the above shown ranges. Due to this a correlation between bond angle and N–O stretching frequency is not possible in these complexes. The complexes containing bridging nitrosyl ligand exhibit the N–O stretching frequency around $1650\text{--}1300\text{ cm}^{-1}$. The bridging nitrosyl ligands are also regarded as linear nitrosyls. Complexes with doubly and

triply bridging nitrosyls are known. Triply bridging nitrosyls absorb at frequencies lower than that of doubly bridging ones.

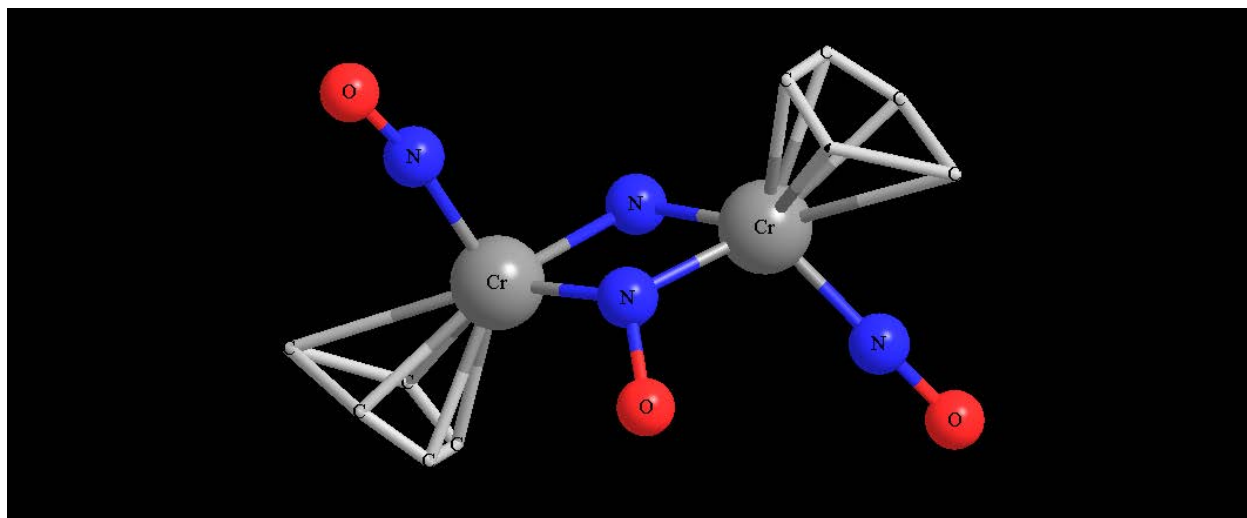

Figure: Structure of $(h^5-C_5H_5)(NO)Cr(\mu-NO)(\mu-NH_2)Cr(NO)(h^5-C_5H_5)$

A bridged binuclear complex of chromium; $[(h^5-C_5H_5)(NO)Cr(\mu-NO)(\mu-NH_2)Cr(NO)(h^5-C_5H_5)]$ is shown in the above figure. The structure contains two terminal M-N-O groups and one double bridging $\mu-NO$ group. In this complex, band due to terminal nitrosyls is seen at 1644 cm^{-1} . The bridged nitrosyl groups absorb at a lower frequency of 1505 cm^{-1} .

The complex $[(h^5-C_5H_5)_3Mn_3(NO)_4]$ contains one triply bridging nitrosyl groups and three double bridging nitrosyl groups. Two bands corresponding to the doubly bridging groups are observed at 1543 cm^{-1} and 1481 cm^{-1} respectively. As expected, the triply bridging nitrosyl absorbs at a lower frequency of 1320 cm^{-1} .

4. CLASSIFICATION OF NITROSYLS

Table: Different types of metal nitrosyls

<i>Type</i>	<i>Examples</i>
<i>Nitrosyl carbonyls</i>	$[\text{Co}^-(\text{NO}^+)(\text{CO})_3]^0$, $[\text{Fe}^{2-}(\text{NO}^+)_2(\text{CO})_2]^0$, $[\text{Mn}^{3-}(\text{NO}^+)_3(\text{CO})]^0$, $[\text{Mn}^-(\text{NO}^+)(\text{CO})_4]^0$, $[\text{V}^-(\text{NO}^+)(\text{CO})_5]^0$
<i>Nitrosyl halides</i>	$[\text{Fe}^-(\text{NO}^+)_2\text{I}]_2$, $[\text{Fe}^-(\text{NO}^+)_2\text{I}]^0$, $[\text{Fe}^0(\text{NO}^+)\text{I}]^0$, $[\text{Fe}^{2-}(\text{NO}^+)_3\text{Cl}]^0$, $[\text{Co}^-(\text{NO}^+)_2\text{X}]^0$ (X=Cl, Br, I)
<i>Nitrosyl thio complexes</i>	$\text{M}^+[\text{Fe}^-(\text{NO}^+)_2\text{S}]^-$, $\text{M}^+[\text{Co}^-(\text{NO}^+)_2\text{S}]^-$, $\text{M}^+[\text{Ni}^-(\text{NO}^+)_2\text{S}]^-$
<i>Nitrosyl cyano complexes</i>	$[\text{Mn}^+(\text{NO}^+)(\text{CN})_5]^{2-}$, $[\text{Fe}^+(\text{NO}^+)(\text{CN})_5]^{2-}$, $[\text{Mn}^+(\text{NO}^+)(\text{CN})_5]^{3-}$, $[\text{Mo}^+(\text{NO}^+)(\text{CN})_5]^{4-}$
<i>Other nitrosyl complexes</i>	$[\text{Co}^+(\text{NO}^+)(\text{NH}_3)_5]^{2+}$, $[\text{Co}^+(\text{NO}^+)(\text{NO}_2)_5]^{3-}$, $[\text{Fe}^+(\text{NO}^+)]^{2+}$, $[\text{Ru}^{2+}(\text{NO}^+)(\text{NH}_3)_4\text{Cl}]^{2+}$, $[\text{Ru}^{2+}(\text{NO}^+)\text{Cl}_5]^{2-}$, $[\text{Fe}^{2-}(\text{NO}^+)_2(\text{PR}_3)_3]^0$

5. SYNTHESIS OF METALLIC NITROSYLS

Preparation of metallic nitrosyl carbonyls:

Metal nitrosyl carbonyls can be obtained by the action of NO on metal carbonyls.

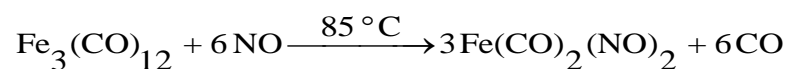
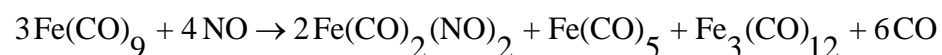
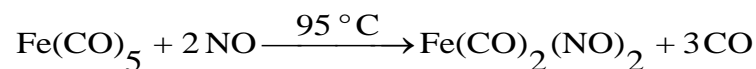

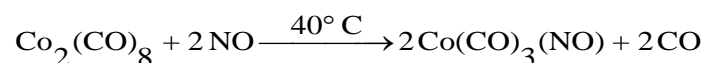

Properties of metal nitrosyl carbonyls:

Substitution reactions:

Since, the nitrosyl ligand is more firmly attached to the metal ion as compared to the carbonyl group; only carbonyl groups can easily be replaced by ligands like PR_3 , CNR , phen.

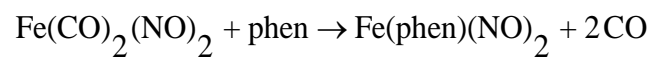
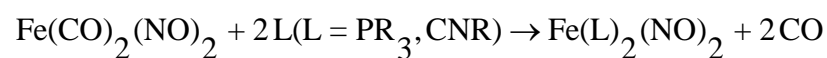

Reaction with halogens:

Halogens can convert carbonyl nitrosyls to metal nitrosyl halides.

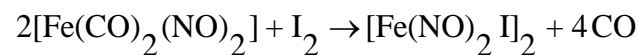

Preparation of metallic nitrosyl halides:

Metal nitrosyl halides can be prepared by the action of nitric oxide on metal halides using a suitable halogen acceptor.

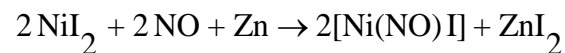
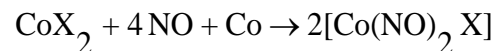

They can also be prepared by halogenation of nitrosyl carbonyls.

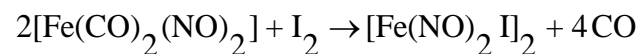

Properties of metal nitrosyl halides:

Metal nitrosyl halides react with other ligands to form mono-nuclear complexes.

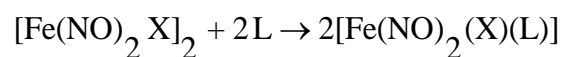

Iron nitrosyl halide reacts with potassium sulphide to form dark red compound with the composition, $\text{K}_2[\text{Fe}_2(\text{NO})_4\text{S}_2]$. This compound can be reacted with methyl chloride to give a compound with composition, $\text{K}_2[\text{Fe}_2(\text{NO})_4(\text{SCH}_3)_2]$. Both these compounds are known as Roussin's red salts. In these compounds, Fe is in -1 oxidation state.

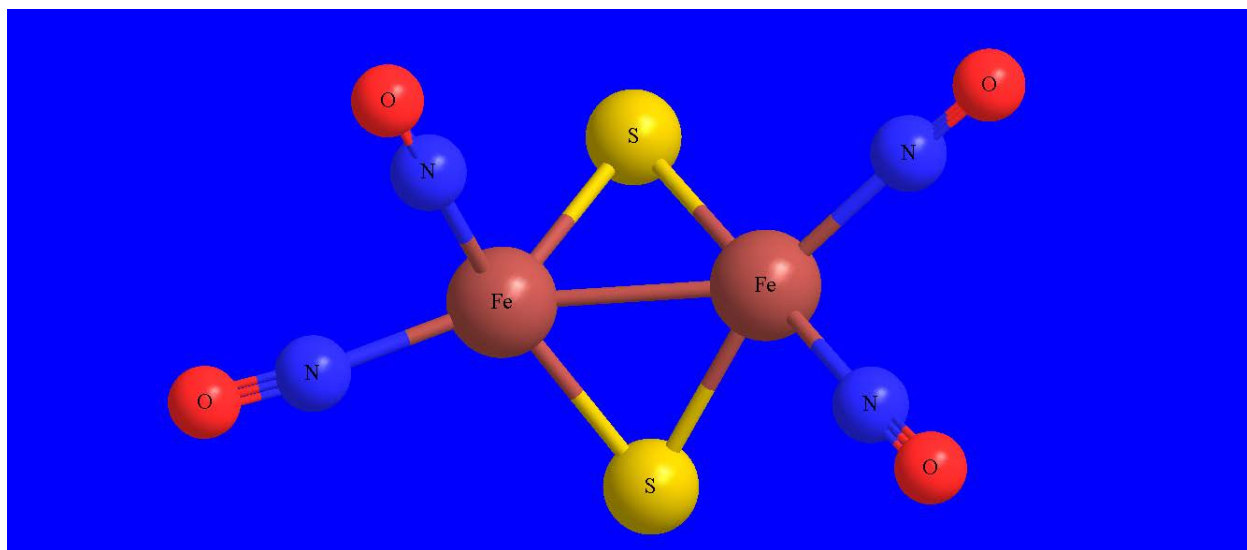
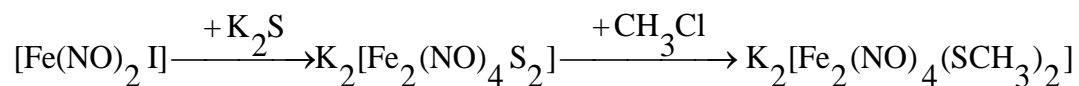

Figure: Structure of Roussin's red salt.

Roussin's black salt is a compound with molecular formula $\text{NaFe}_4\text{S}_3(\text{NO})_7$ which is obtained upon mild acidification of the red salt. The red salt can be brought back by alkalization.

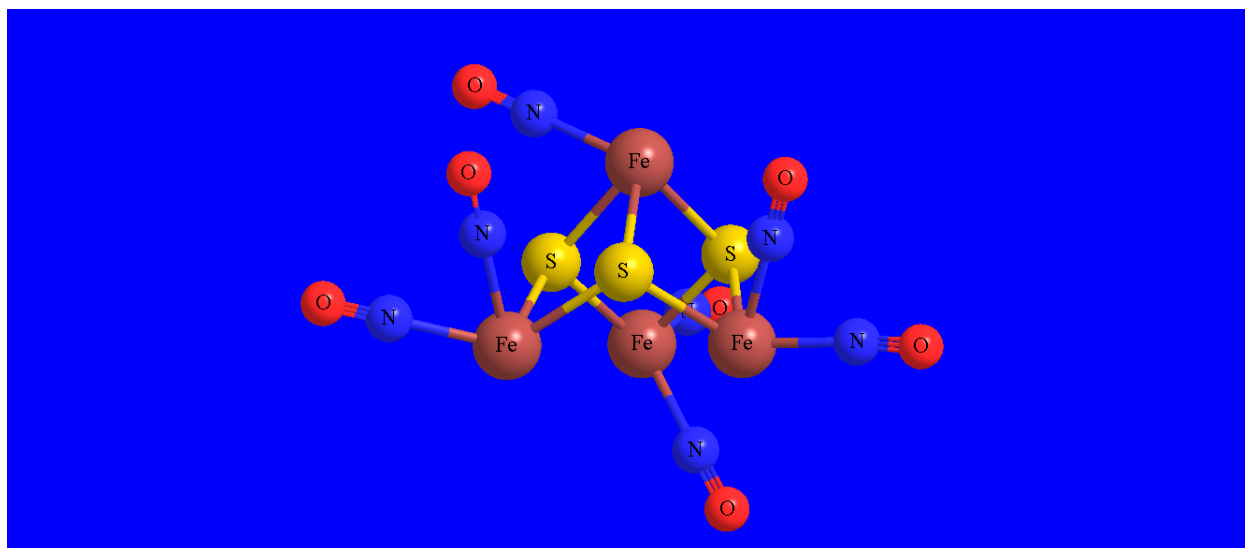

Figure: Structure of Roussin's black salt.

Both the Roussin salts find applications as nitric oxide donor in medicinal and food processing fields.

LECTURE #14**6. INDIVIDUAL NITROSYLS**

$\text{Na}_2[\text{Fe}^{2+}(\text{CN})_5(\text{NO}^+)]$, **Sodium pentacyano nitrosyl ferrate (II)** also known as **Sodium nitroprusside:**

Preparation:

It is prepared by the action of sodium nitrite on sodium ferrocyanide

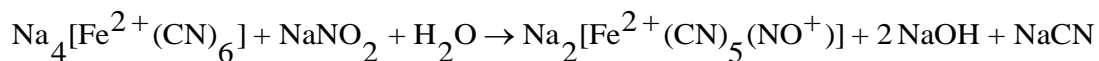

It can also be prepared by passing nitric oxide in a solution of sodium ferrocyanide in acidic medium.

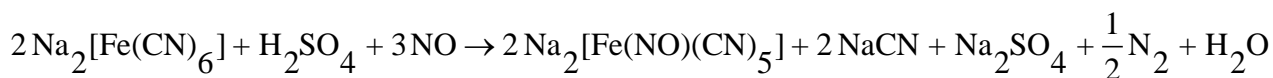

It has been prepared from potassium ferrocyanide too. Upon boiling a solution of potassium ferrocyanide with concentrated nitric acid, a mixture of potassium nitrate, potassium ferricyanide and nitric oxide is produced. Subsequent to the crystallization and removal of potassium nitrate, the neutralization of the reaction mixture yields sodium nitroprusside.

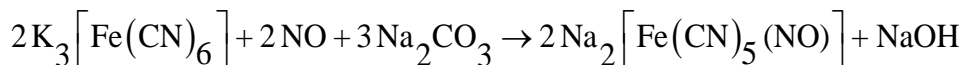
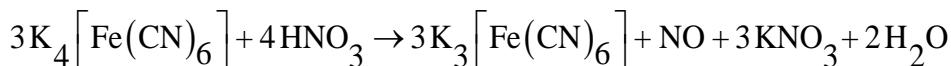
**Structure:**

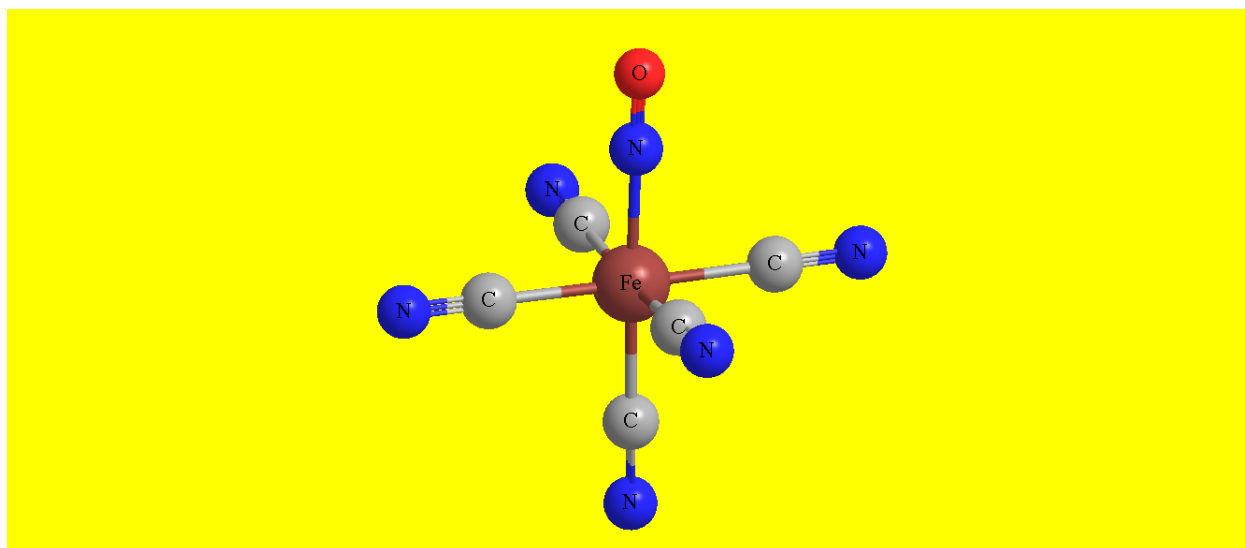

Figure: Structure of sodium nitroprusside.

The sodium nitroprusside has an octahedral ferrous ion centre surrounded by five cyano ligands and one nitrosyl ligand. In $[\text{Fe}(\text{CN})_5(\text{NO})]^{2-}$ the total positive charge is three units [Fe^{+2} and NO^+] and the negative charge is five units created due to five cyano groups. Hence the resultant charge over the ion is -2.

Properties:

Sodium nitroprusside forms beautiful ruby red rhombic crystals, which are soluble in water and practically insoluble in acetone, ether and chloroform.

It is diamagnetic which proves that the nitric oxide is present as nitrosyl ion in this complex.

It reacts with sodium hydroxide to give sodium ferrocyanide.

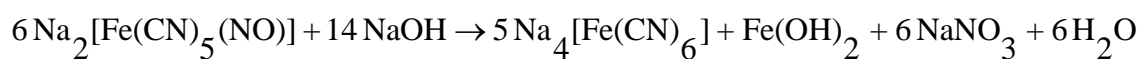

Freshly prepared solution of sodium nitroprusside gives different colouration as shown below:

Violet colouration in presence of sulphide ions.

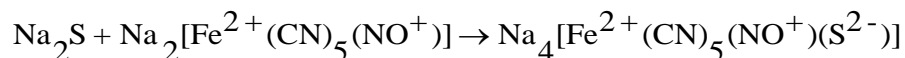

Red colouration with sulphites of alkali metals.

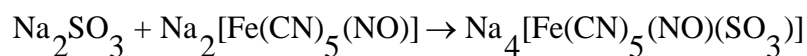

Flesh colouration with silver nitrate.

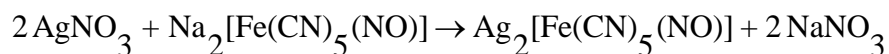

Deep red colour with aldehydes and ketones containing $\text{CH}_3\text{-CO-R}$ group in excess of sodium hydroxide.

Uses:

It is used as a reagent in qualitative analysis for the detection of sulphides, sulphites, aldehydes and ketones containing $\text{CH}_3\text{-CO-R}$ group.

It is used as a reference compound for calibration of a Mossbauer spectrometer.

It is used to detect illicit substance like secondary amines in forensic laboratories (Simon's test).

It is used to control blood pressure.

It is used to treat hyper tension.

$[\text{Fe}^+(\text{NO}^+)(\text{H}_2\text{O})_5]\text{SO}_4$, Nitroso ferrous sulphate:

It can be prepared by reacting a metal nitrate and ferrous sulphate in presence of few drops of sulphuric acid. The reaction occurs in following three steps:

Metal nitrate reacts with sulphuric acid to produce nitric acid

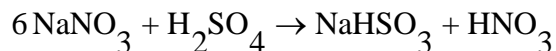

Nitric acid oxidises the ferrous ion (light green) into ferric ion (reddish brown) and itself gets reduced to nitric oxide

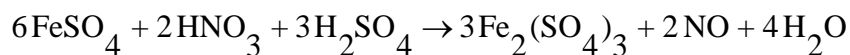

Nitric oxide is absorbed by unreacted ferrous sulphate to form a dark brown ring nitroso ferrous sulphate.

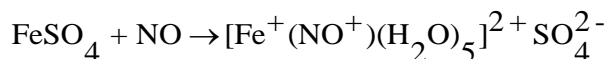

In aqueous solution nitroso ferrous sulphate is in penta aqua form $[\text{Fe}(\text{NO})(\text{H}_2\text{O})_5]^{2+}$. It is a paramagnetic complex with three unpaired electrons showing a magnetic moment of 3.90 B.M. This value of magnetic moment supports the +1 oxidation state of iron (d^7) in a high spin complex ion.

The formation of brown ring is a well-known observation for detection of nitrate in inorganic salts.

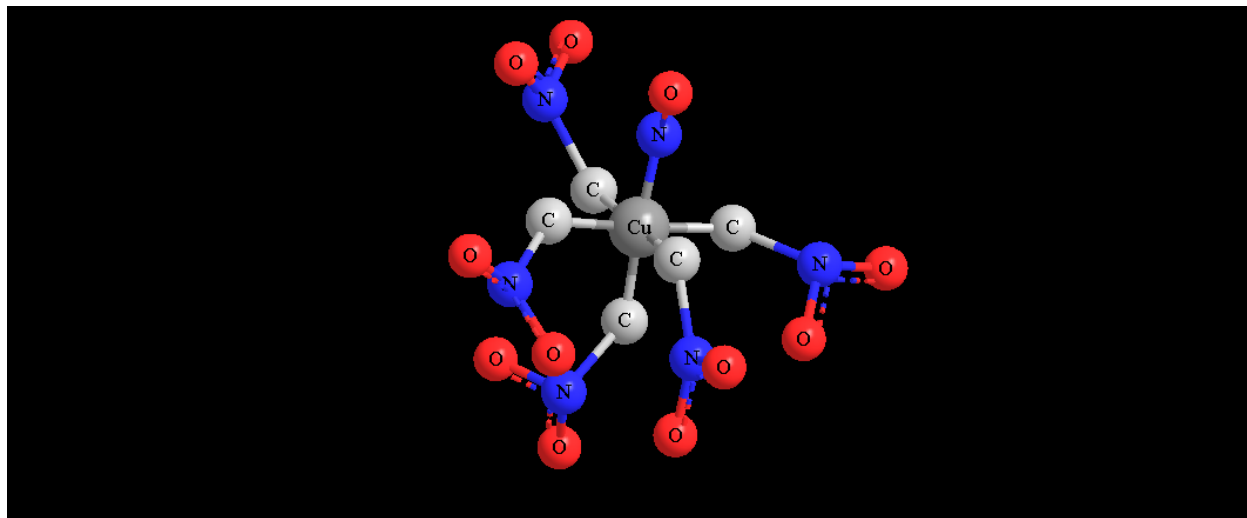
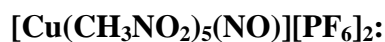

Figure: Structure of $[\text{Cu}(\text{CH}_3\text{NO}_2)_5(\text{NO})][\text{PF}_6]_2$

A M Wright and co-workers have recently synthesized and structurally characterised a copper nitrosyl complex, $[\text{Cu}(\text{CH}_3\text{NO}_2)_5(\text{NO})][\text{PF}_6]_2$ which is the first of its kind. Addition of NO^+PF_6^- to powdered metallic copper in nitromethane results in the formation of the said complex. The corners of an octahedron are occupied by five CH_3NO_2 ligands and one NO^+ ligand in this complex ion. The observed Cu-N-O bond angle in the complex is 121° which suggests that the nitric oxide is bound as NO^+ ion in this complex. The Cu—N bond in this complex is found to be much weaker as compared to other Cu—NO complexes. Application of vacuum at room temperature results in to release of nitric oxide gas from the complex. This complex has a promising potential application as nitric oxide donor.

LECTURE #15**7. EFFECTIVE ATOMIC NUMBER (EAN) RULE:**

The EAN for metallic nitrosyls can be calculated in a manner similar to that of carbonyls. In metallic nitrosyls, the metals exhibit variable oxidation state. Hence, instead of considering the nuclear charge Z for the calculation, $Z+n$ should be used. Here 'n' indicates the number of electrons gained or lost by the metal to achieve the oxidation state observed in the nitrosyl complex.

The EAN for $[\text{Co}^-(\text{CO})_3(\text{NO}^+)]^0$ can be calculated as follows:

$$\text{EAN} = Z + n + a + b + c$$

Here,

Co ($Z = 27$) is in -1 oxidation state which is achieved by gaining one electron. Hence $n = +1$.

Moreover, all the four ligand groups (three carbonyls and one nitrosyl) are terminal groups each donating an electron pair i.e. $a = 4 \times 2 = 8$.

There are no bridge bonds or M-M bonds in the complex. Therefore, both b and c equals zero.

Thus,

$$\text{EAN} = 27 + 1 + 8 + 0 + 0 = 36 \text{ [Kr]}$$

Thus $[\text{Co}^-(\text{CO})_3(\text{NO}^+)]^0$ obeys the EAN rule.

Table: Calculation of effective atomic number (EAN) in some nitrosyls.

<i>Metal Nitrosyl</i>	<i>Z + n</i>	<i>a</i>	<i>b</i>	<i>c</i>	<i>EAN=</i> <i>Z + n + a + b + c</i>
$[Co^-(CO)_3(NO^+)]^0$	27+1	4 x 2 = 8	0	0	36 [Kr]
$[Fe^{2-}(CO)_2(NO^+)_2]^0$	26+2	4 x 2 = 8	0	0	36 [Kr]
$[Mn^{3-}(CO)(NO^+)_3]^0$	25+3	4 x 2 = 8	0	0	36 [Kr]
$[Cr^+(NO^+)(CN)_5]^3$	24-1	6 x 2 = 12	0	0	35
$[Fe^+(NO^+)(H_2O)_5]^2$	26-1	6 x 2 = 12	0	0	37
$[Co^{+3}(NO^-)(CN)_5]^3$	27-3	6 x 2 = 12	0	0	36 [Kr]
$[Fe^{-2}(NO^+)_3(NO^-)]^2$	26+2	4 x 2 = 8	0	0	36 [Kr]

EXERCISES**MULTIPLE CHOICE QUESTIONS**

- Which of the following species is isoelectronic with carbon monoxide?
 - NO^+
 - NO
 - NO^-
 - none of these
- How many electrons does nitric oxide donate when bonded to metal as NO^+ ?
 - 1
 - 2
 - 3
 - 4
- The expected value for $\angle M - N - O$ in complexes containing NO^+ ligand is_____
 - 180
 - 120
 - 90
 - uncertain

4. The expected value for $\angle M - N - O$ in complexes containing NO^- ligand is _____
- (a) 180 (b) 120 (c) 90 (d) uncertain
5. In which test is nitroso ferrous sulphate produced?
- (a) Brown ring (b) Simon's test (c) azo dye test (d) Fehling's test test
6. Sodium nitroprusside is useful in treatment of _____
- (a) hepatitis (b) hypertension (c) cancer (d) diabetes

SHORT / LONG ANSWER QUESTIONS

1. Using the donor pair method, perform the electron count for $[Cr(CN)_5(NO)]^{4-}$ considering (i) Cr-N-O angle = 120° (ii) Cr-N-O angle = 180° .

Solution:

Bent (120°):	5 CN^-	10 e^-	Linear (180°):	5 CN^-	10 e^-
	1 NO^-	2 e^-		1 NO^+	2 e^-
	Cr^{2+}	4 e^-		Cr^0	6 e^-
	Total	16 e^-		Total	18 e^-

2. For an 18 electron complex ion, $[Fe(CN)_5(NO)]^{2-}$ what is the expected M-N-O angle? Why?
3. “ NO^+ is three electron donor while NO^- is one electron donor.”: Justify.
4. Discuss the infrared spectra of $[CoCl_2(NO)(PCH_3Ph_2)_2]$.
5. Why is it difficult to correlate the N – O stretching frequencies with $\angle M - N - O$ in case of nitrosyl complexes? Explain.

MODULE 3: ISOMERISM

Key words: Structural isomerism; stereo isomerism; geometrical isomerism; optical activity;

Grinberg's method; Kurnakov reaction; enantiomers; racemic mixture

MODULE 3: ISOMERISM

LECTURE #16

1. INTRODUCTION

Two or more different compounds can have the same molecular formula. Hence, molecular formula alone is not sufficient to identify a coordination compound. Two or more different compounds having the same molecular formula are called isomers and the phenomenon is called isomerism. The isomers may or may not exhibit same properties. The complex $[\text{Pt}(\text{Cl})_2(\text{NH}_3)_2]$ can have two isomers out of which one of the isomer known as cis-platin is found to be very effective against cancer whereas the trans-platin is not useful for the treatment of cancer. In the present study, a wide variety of isomerism in coordination compounds has been included. The categories discussed here are not mutually exclusive and hence two or more types of isomerism may have to be invoked to fully describe the isomerism between complexes. Methods of structure determination like X-ray diffraction have been useful in identifying many isomers of coordination compounds.

2. CLASSIFICATION OF ISOMERISM:

Following Werner, the isomerism that occurs in metal complexes can be classified as under:

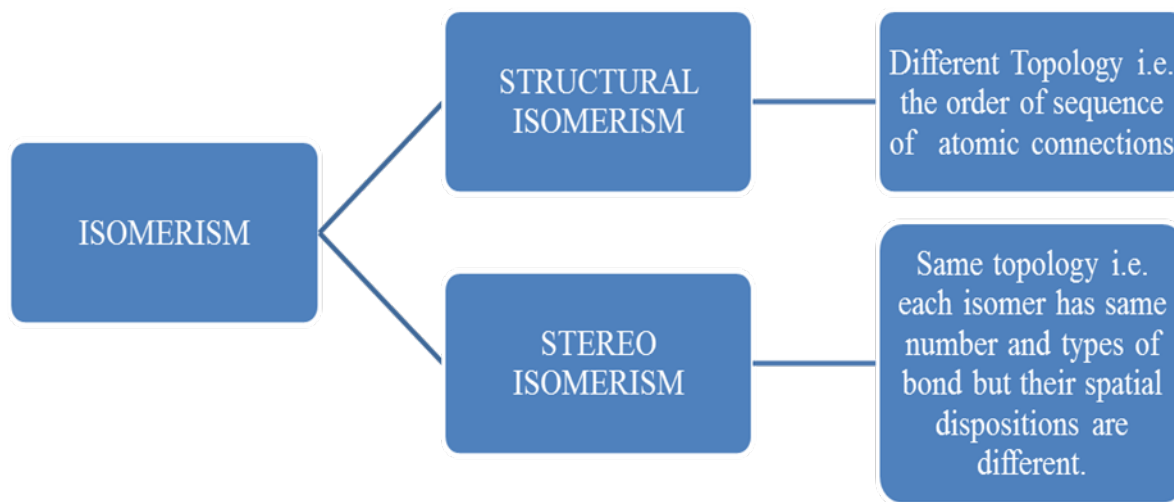

Figure: Broad Classification of Isomerism in Metal Complexes.

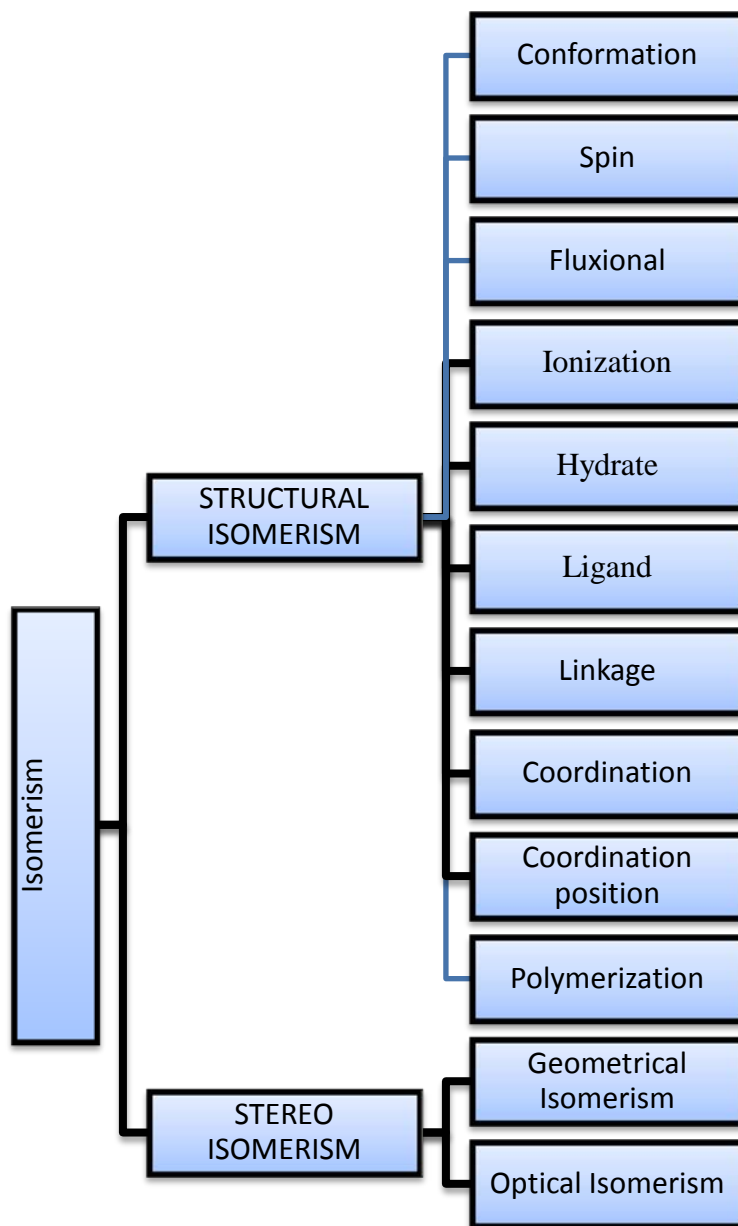

Figure: Detailed Classification of Isomerism in Metal Complexes.

3. STRUCTURAL ISOMERISM:

1) Conformation isomerism:

The isomers that differ only with respect to stereochemistry point of view are named as conformation isomers.

Complexes of only a few metal ions exhibit this type of isomerism. The d^8 metal ions exhibit conformation isomerism. The complex $\text{NiCl}_2(\text{Ph}_2\text{PCH}_2\text{PPh}_2)_2$ existing in both trans square planar and tetrahedral stereochemistry as shown in figure below is a typical example of conformation isomerism.

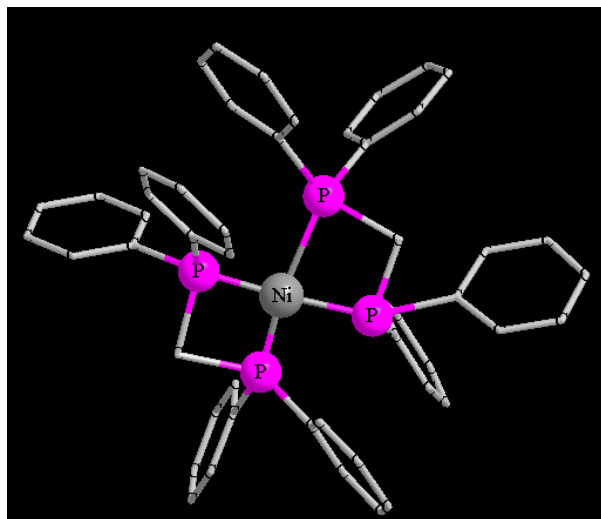

Square planar Ni(II)(dppm) complex

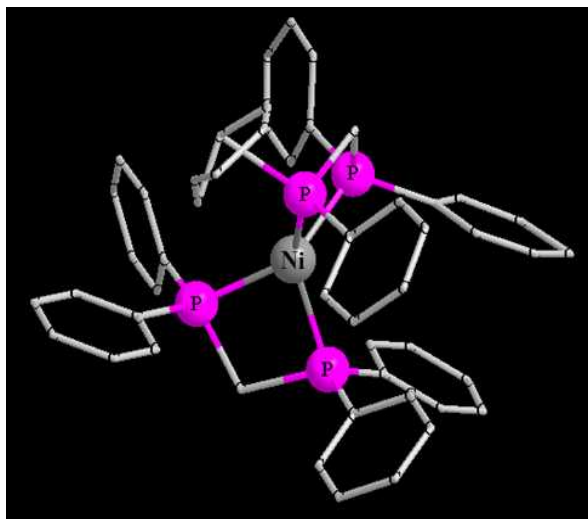

Tetrahedral Ni(II)(dppm) complex

Many a times, the difference in stereochemistry results in difference in magnetic properties of a complex. Square planar complexes of Ni (II) are diamagnetic whereas the tetrahedral ones are paramagnetic. Hence, some of the conformation isomers are also spin isomers.

2) Spin isomerism

Isomerism observed due to different electron spins in complexes of same geometry is known as spin isomerism. In some of the complexes of Fe (II), Fe (III) and Co (II), the metal ions are known to exist in both high spin and low spin states. Fe (III) ion in an octahedral ligand field can have either high spin $(t_{2g})^5 (e_g)^0$ or low spin $(t_{2g})^3 (e_g)^2$ configuration as shown below.

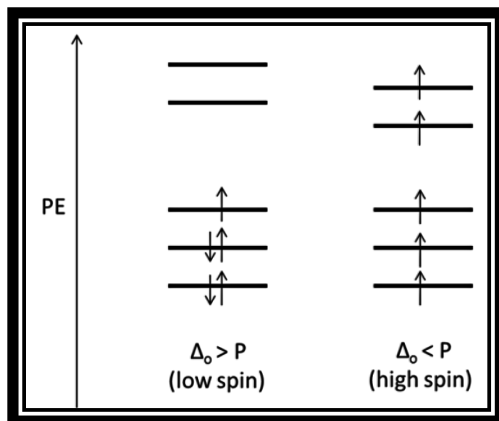

Figure : Spin states for Fe(III), a d^5 ion in octahedral ligand field

Spin isomerism is known to be present in a complex $[\text{Fe}^{+3}(\text{S}_2\text{CNMe}_2)_3]$

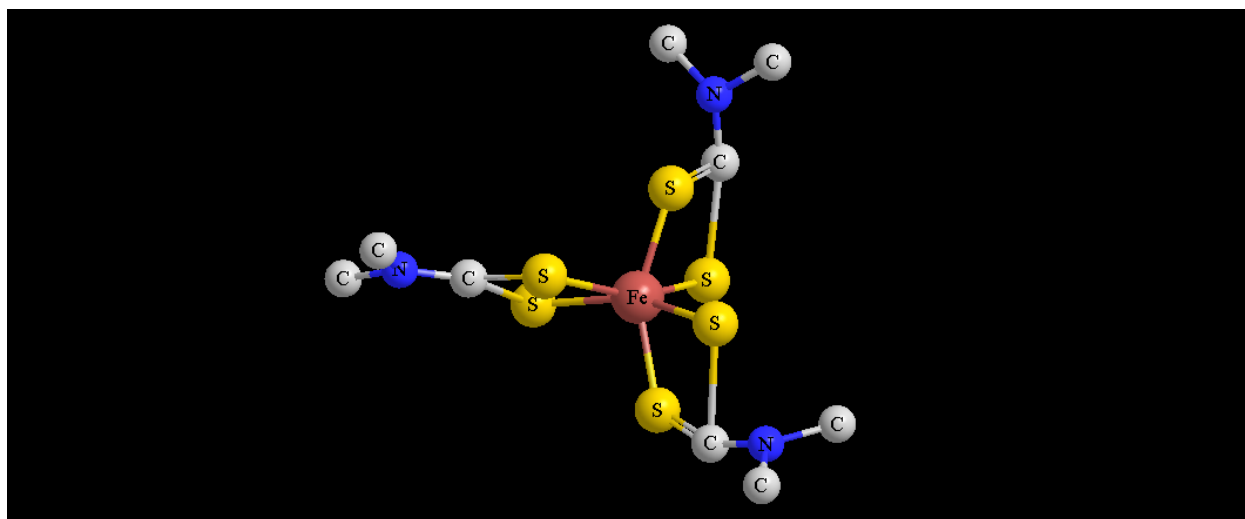

Figure: Structure of $[\text{Fe}^{+3}(\text{S}_2\text{CNMe}_2)_3]$

Spin isomers coexist in the sample but their lifetimes are very short ($\sim 10^{-7}$ s) and hence are very difficult to distinguish. The spin isomerism behaviour in solution and solid states are found to be different.

3) Fluxional isomerism

Fluxional molecules are the molecules that rapidly undergo intramolecular rearrangements among their constituent atoms. Such phenomenon exhibited by ketones / phenols is termed as tautomerism in organic chemistry.

Earlier during the discussion on polynuclear metal carbonyls, we have seen that dicobaltoctacarbonyl, $[\text{Co}_2(\text{CO})_8]$ exhibits coexistence two structures.

The molecule $\eta^5\text{-C}_5\text{H}_5\text{Mn}(\text{CO})_3$, shown in the figure below is capable of showing fifteen fluxional isomers.

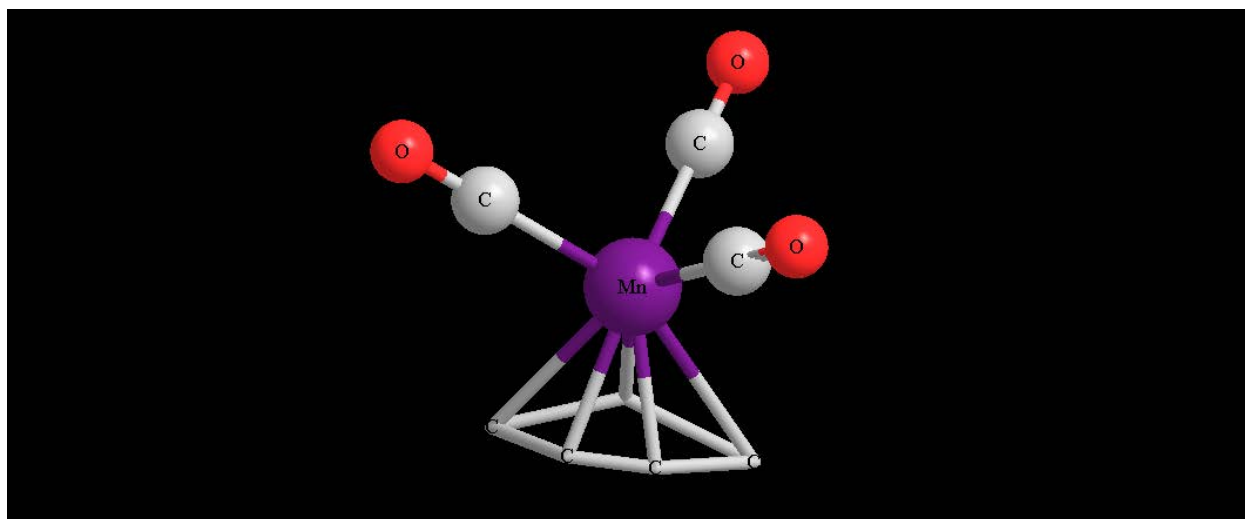

Figure : Structure of $\eta^5\text{-C}_5\text{H}_5\text{Mn}(\text{CO})_3$

From the structure, it is seen that the unit $\eta^5\text{-C}_5\text{H}_5\text{Mn}$ has a five-fold rotational axis due to the cyclopentadienyl ring. Similarly, the unit $\text{Mn}(\text{CO})_3$ possess a three –fold rotational axis due to the three carbonyl groups. Combining these two sets of axes, there are in all 15 rotational isomers (fluxional isomers) possible in this molecule. A 15 fold rotational axis affords an angle of 24° ($360^\circ / 15 = 24^\circ$) between two equipotential arrangements. In addition to this, a negligible energy change is involved during the interchange. Thus, individual nomenclatures of all these structural isomers are avoided and are collectively named as fluxional molecules.

LECTURE #17**4) Ionization Isomerism:**

Isomers that give different ions in the solution are called ionization isomers.

An example of a pair of ionization isomers is $[\text{Co}(\text{NH}_3)_5\text{Br}]\text{SO}_4$ & $[\text{Co}(\text{NH}_3)_5\text{SO}_4]\text{Br}$.

These two isomers can be easily identified by performing tests for sulfate and bromide ions in their aqueous solutions.

$[\text{Co}(\text{NH}_3)_5\text{Br}]\text{SO}_4$ gives white precipitates of barium sulphate with an aqueous solution of barium chloride. It does not give the test for bromide ion.

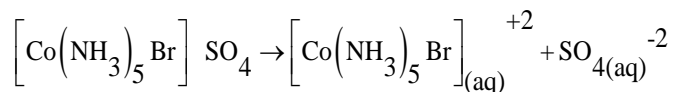

While $[\text{Co}(\text{NH}_3)_5\text{SO}_4]\text{Br}$ gives pale yellow precipitates of silver bromide with an aqueous solution of silver nitrate, but it does not give the test for sulphate ion.

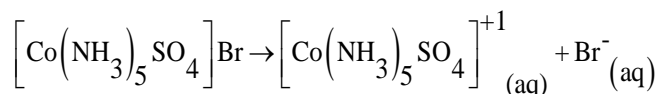

Few more examples of ionization isomers are listed below:



The structural formulae of ionisation isomers can be deduced by the measurement of molar conductance. Consider the following example:

If a complex having molecular formula $\text{CrCl}_4\text{H}_2\text{O}$ exhibits molar conductance corresponding to two ions, the dissociation can only be written as

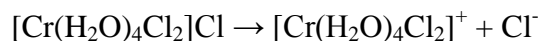

The above formula can be verified by measuring the amount of precipitation of AgCl using AgNO_3 .

5) Hydrate Isomerism:

The isomers in which coordinated ligands are replaced by water molecules are known as hydrate isomers.

Green crystals of chromium (III) chloride are formed in hot aqueous solution upon reduction of chromium (IV) oxide with hydrochloric acid. When these crystals are dissolved in water, the chloride ligands in the complex are slowly replaced by water to give blue green and finally violet coloured complexes.

1 g quantity of these three dark green, blue green and violet coloured isomers of a complex with molecular formula $\text{CrCl}_3\cdot 6\text{H}_2\text{O}$ when treated with dehydrating agents attained a constant weight of 0.865 g, 0.932 g and 1 g respectively.

Using this information, it is possible to identify the structural formula of the isomers as follows:

The molecular weight of $\text{CrCl}_3\cdot 6\text{H}_2\text{O} = 52 + (35.5 \times 3) + (6 \times 18) = 266.5 \text{ g}$

1 g of dark green isomer loses $(1 - 0.865) = 0.135 \text{ g}$ of H_2O

Therefore, 266.5 g of dark green isomer loses $(0.135 \times 266.5) = 36.0$ g of H_2O which corresponds to two water molecules. Thus, the dark green isomer has two water molecules outside the coordination sphere of the complex.

Similarly,

1 g of blue green isomer loses $(1 - 0.932) = 0.068$ g of H_2O

Therefore, 266.5 g of dark green isomer loses $(0.068 \times 266.5) = 18.12$ g of H_2O which corresponds to one water molecule. Thus, the blue green isomer has only one water molecules outside the coordination sphere of the complex.

Since, the violet isomer does not lose any weight; there is no water molecule in the outer shell of this isomer.

Also, it has been observed that 1 g quantity of these three dark green, blue green and violet coloured isomers of a complex with molecular formula $\text{CrCl}_3\cdot 6\text{H}_2\text{O}$ when treated with excess of silver nitrate precipitate AgCl in the amount of 0.538 g, 1.076 g and 1.614 g respectively.

Using this information, it is possible to identify the structural formula of the isomers as follows:

The molecular weight of $\text{CrCl}_3\cdot 6\text{H}_2\text{O} = 52 + (35.5 \times 3) + (6 \times 18) = 266.5$ g

The molecular weight of $\text{AgCl} = 108 + 35.5 = 143.5$

1 g of dark green isomer gives 0.538 g AgCl

Therefore, 266.5 g of dark green isomer gives $(0.538 \times 266.5) = 143.37$ g of AgCl which corresponds to one Cl^- ion. Thus, the dark green isomer has one chloride ion outside the coordination sphere of the complex.

Similarly,

1 g of blue green isomer gives 1.076 g AgCl

Therefore, 266.5 g of dark green isomer loses $(1.076 \times 266.5) = 86.7$ g of AgCl which corresponds to two Cl^- ions. Thus, the blue green isomer has two chloride ions outside the coordination sphere of the complex.

And,

1 g of violet isomer gives 1.614 g AgCl

Therefore, 266.5 g of dark green isomer loses $(1.614 \times 266.5) = 430.13$ g of AgCl which corresponds to three Cl^- ions. Thus, the violet isomer has three chloride ions outside the coordination sphere of the complex.

From the above calculations the structural formula of the three isomers are obtained and tabulated as below:

$[\text{Cr}(\text{H}_2\text{O})_6]\text{Cl}_3$ Violet	$[\text{Cr}(\text{H}_2\text{O})_5\text{Cl}]\text{Cl}_2 \cdot \text{H}_2\text{O}$ Blue green	$[\text{Cr}(\text{H}_2\text{O})_4\text{Cl}_2]\text{Cl}_2 \cdot 2\text{H}_2\text{O}$ Dark green
Gives three chloride ions in aqueous solution	Gives two chloride ions in aqueous solution	Gives one chloride ion in aqueous solution
No moisture loss upon dehydration.	Loss of moisture corresponding to two water molecules upon dehydration.	Loss of moisture corresponding to three water molecules upon dehydration.

Few more examples of hydrate isomerism are:

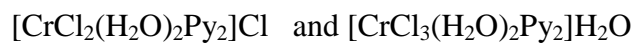
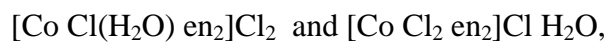

6) Ligand Isomerism:

The complexes of isomeric ligands are known as ligand isomers.

1,2-diaminopropane and 1,3-diaminopropane form complexes showing ligand isomerism as shown in the figure.

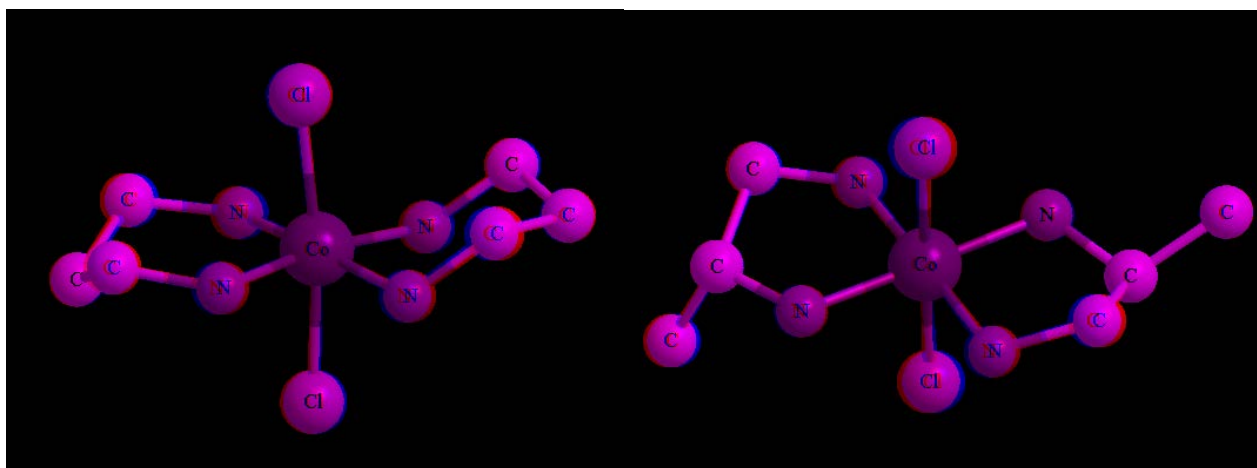

1, 3-diaminopropane complex

1, 2-diaminopropane complex

(View Movie: [flv 1\1, 2-diaminopropane complex.flv](#),

[flv 1\1, 3-diaminopropane complex.flv](#))

7) Linkage Isomerism:

The ligands that are capable of binding the metal ion using either of the more than one coordinating atoms are called ambidentate ligands. NO_2^- is an ambidentate ligand as it can

coordinate either through nitrogen or oxygen atom. SCN^- and $\text{S}_2\text{O}_3^{2-}$ are also ambidentate ligands.

The isomers formed when ambidentate ligands use different coordinating atoms for binding the metal ion are known as linkage isomers.

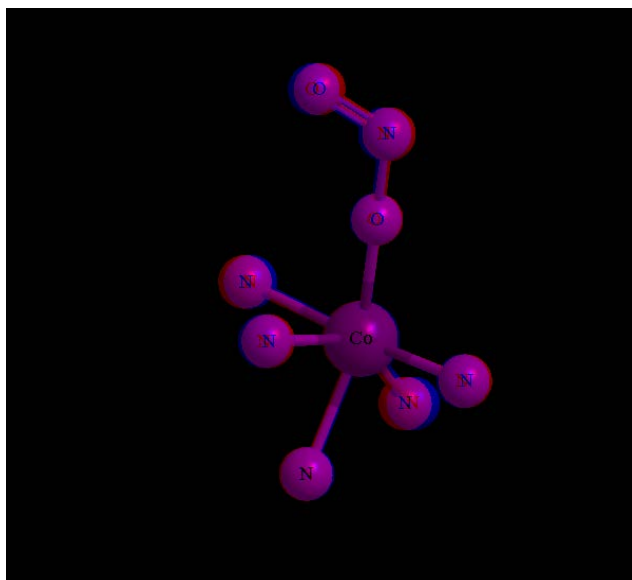

$[\text{Co}(\text{NO}_2)(\text{NH}_3)_5]\text{Cl}$

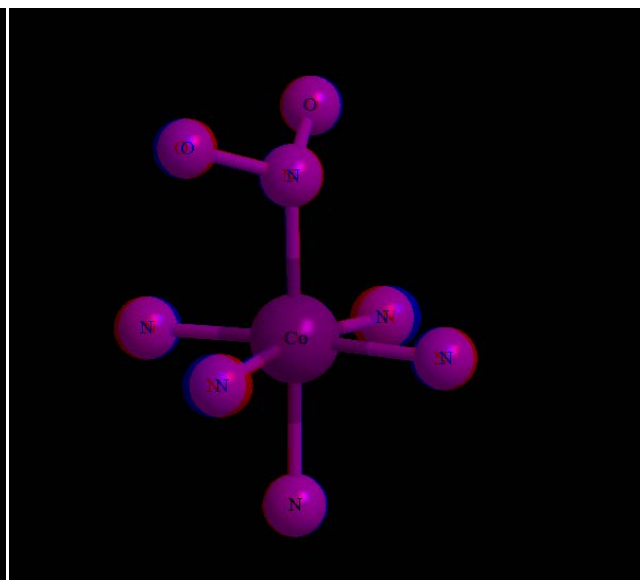

$[\text{Co}(\text{ONO})(\text{NH}_3)_5]\text{Cl}$

(View movie: [flv 1\\[Co\(NO2\)\(NH3\)5\]Cl.flv](#), [flv 1\\[Co\(ONO\)\(NH3\)5\]Cl.flv](#))

LECTURE #18

8) Coordination Isomerism:

The isomers having both cationic and anionic parts as complexes with a different distribution of ligands and /or metal ions are known as coordination isomers.

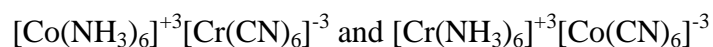
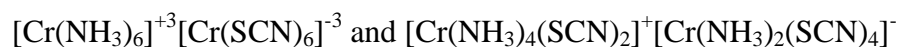

9) Coordination Position Isomerism:

Isomers of bridged polynuclear complexes having different distribution of non-bridging ligands with respect to the metal ion are known as coordination position isomers. e.g.

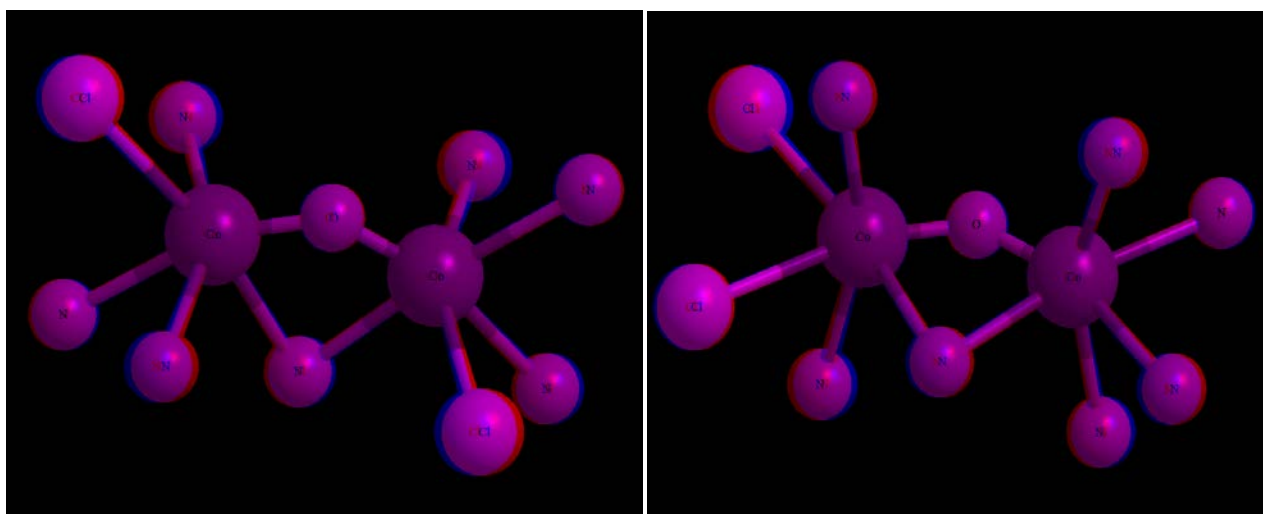

Symmetrical

Unsymmetrical

(View movie: [flv 1\Symmetrical.flv](#), [flv 1\Unsymmetrical.flv](#))

10) Polymerization isomerization

Polymerization isomerism represents variable value of 'x' in a complex $[ML_n]_x$. Actually it is not an isomerism but it is included in this list because it represents an additional way in which an empirical formula may give incomplete information about the nature of complex. All members of the series; $[Co(NH_3)_3(NO_2)_3]_x$ are polymerization isomers as shown below:

<i>Empirical formula</i>	<i>Value of 'x'</i>
$[Co(NH_3)_3(NO_2)_3]$	1
$[Co(NH_3)_6] [Co(NO_2)_6]$	2
$[Co(NH_3)_4(NO_2)_2] [Co(NH_3)_2(NO_2)_4]$	2
$[Co(NH_3)_5(NO_2)] [Co(NH_3)_2(NO_2)_4]_2$	3
$[Co(NH_3)_6] [Co(NH_3)_2(NO_2)_4]_3$	4
$[Co(NH_3)_4(NO_2)_2]_3 [Co(NO_2)_6]$	4
$[Co(NH_3)_5(NO_2)_6]_3 [Co(NO_2)_6]_2$	5

4. STEREO ISOMERISM OR SPACE ISOMERISM:

The isomers that differ with respect to the relative orientation of bonds are known as stereo isomers or space isomers. There are two forms of stereoisomerism.

Geometrical Isomerism (diastereoisomerism)

Optical Isomerism (mirror image isomerism)

1. Geometrical Isomerism: 4-Coordinate complexes:

The arrangement of four ligands around the central metal atom may be tetrahedral or square planar.

Tetrahedral complexes:

Tetrahedral complexes of the types $[Ma_4]$, $[Ma_2b_2]$ or $[Mabcd]$ can exist in only one geometrical form as the arrangement of every ligand around the central metal atom in space is equivalent in every respect. They do not exhibit geometrical isomerism

Square planar complexes:

The two distinguished forms of $[Pt(NH_3)_2Cl_2]$ led a surge in proposing square planar structure for four coordinated complexes of Pt(II) ion.

A square planar complex $[Ma_2b_2]$ can exist in 1,2 (cis) and 1,3 (trans) form.

The terms cis- and trans- refer to the positions of two groups with respect to each other. In the cis- isomer they are next to each other or at an angle of 90° with respect to the central metal ion, whereas in the trans- isomer they are opposite each other i.e. at 180 degrees relative to the central

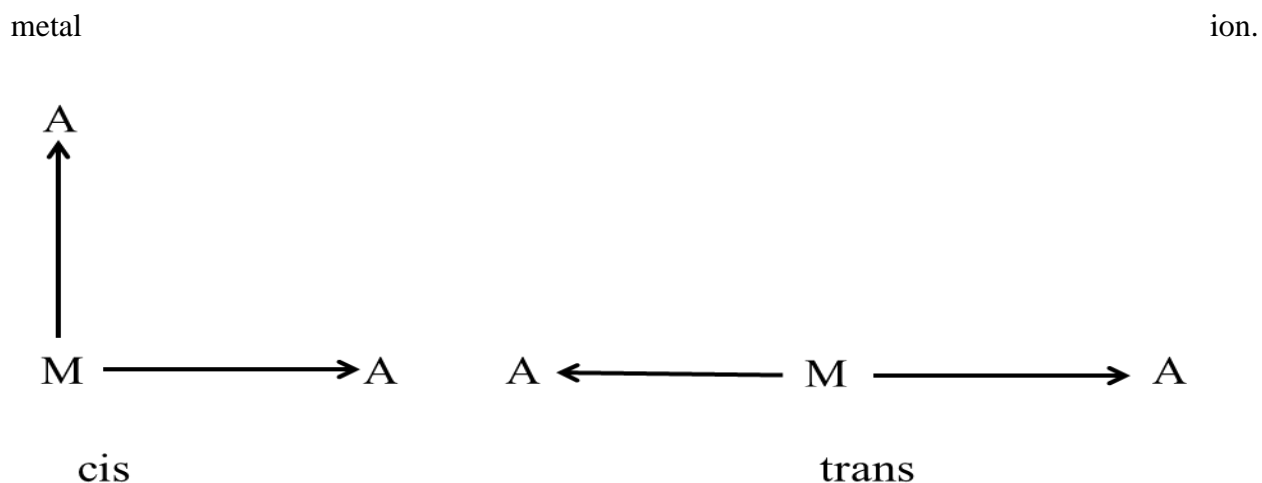

Tsherniaev isolated the three forms predicted for the planar species $[Mabcd]$ of the complex $[\text{Pt}(\text{NH}_3)(\text{NH}_2\text{OH})\text{Py}(\text{NO}_2)]\text{Cl}$ providing elegant support to the Werner's postulation. The planar structure of 4-coordinate complexes has since then been confirmed by physical methods of structure determination like dipole moment measurement, vibrational spectroscopy and X-ray diffraction. Planar complexes are formed by the central metal ions like Co (II), Ni (II), Cu (II), Au (III), Pd (II) having d^7 , d^8 or d^9 configuration.

No stereoisomers are possible for planar species of the type $[\text{Ma}_4]$, $[\text{Ma}_3\text{b}]$ or $[\text{Mab}_3]$ because all possible arrangements of a and b for each of these types are exactly equivalent.

Following type of square planar complexes show geometrical isomers:

I. Square planar complexes containing only monodentate ligand:i. $[\text{Ma}_2\text{b}_2]^{\pm n}$ type:

Here M is central ion while a and b are monodentate ligands. Complexes of this type exist as cis-trans isomers.

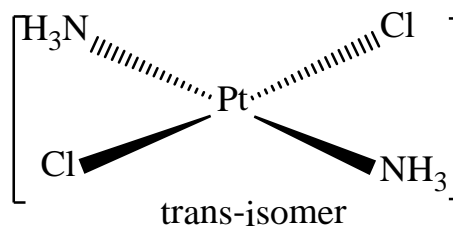
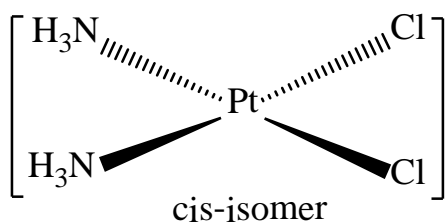

In all such isomers, all the four bonds are coplanar with the central atom.

Similarly $[\text{Pd}(\text{NH}_3)_2(\text{NO}_3)_2]$ also shows cis and trans isomers.

ii. $[\text{Ma}_2\text{bc}]^{\pm n}$ type:

In this type of complexes, a is any neutral monodentate ligand like NH_3 , py, H_2O while b and c are anionic Monodentate ligands like Cl^- , Br^- and NO_2^- .

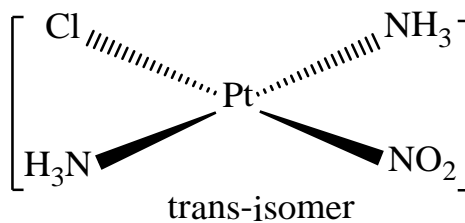
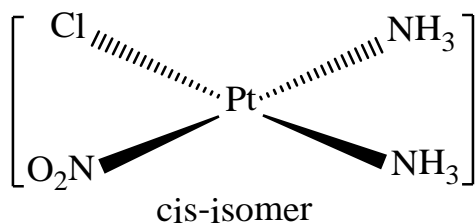

iii. $[Mabcd]^{±n}$ type:

Pt(II) ion forms a number of complexes of this type. Complexes of this type exist in three isomeric forms as shown below.

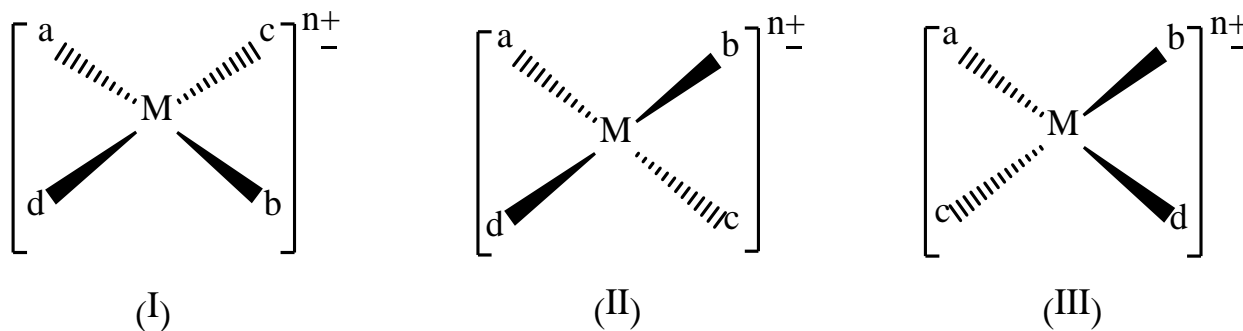

Few more examples are $[Pt(NH_3)ClBrNO_2]$, $[Pt(NH_3)_2pyClBr]$, $[Pt(NO_2)py(NH_3)(NH_2OH)]^+$, $[Pt(C_2H_4)(NH_3)ClBr]$.

II. Square planar complexes containing unsymmetrical bidentate chelating ligands:

i. $[M(AB)_2]^{±n}$

Complexes containing unsymmetrical bidentate chelating ligands can also exist as cis and trans isomers of type $[M(AB)_2]^{±n}$, where AB is unsymmetrical bidentate chelating ligand.

e.g. $[Pt(gly)_2]$ where gly is $NH_2-CH_2COO^-$ (glycine ion), exists in following cis-trans isomeric forms

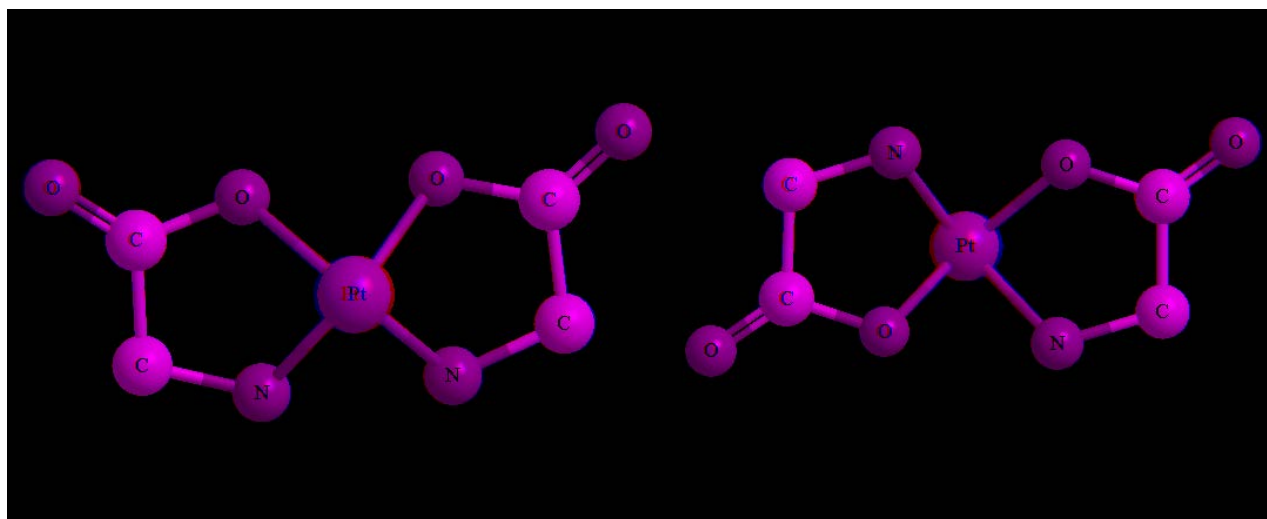

cis-[Pt(gly)₂]

trans-[Pt(gly)₂]

(View Movie: [flv 1\cis-\[Pt\(gly\)2\].flv](#), [flv 1\trans-\[Pt\(gly\)2\].flv](#))

III. Square planar complexes containing symmetrical bidentate chelating ligands:



Complexes containing symmetrical bidentate chelating ligands can also exist cis and trans isomers of type $[M(AA)_2]^{\pm n}$, where AA is symmetrical bidentate chelating ligands .

e.g. $[Pt(NH_2CH(CH_3)CH(CH_3)NH_2)_2]^{+2}$

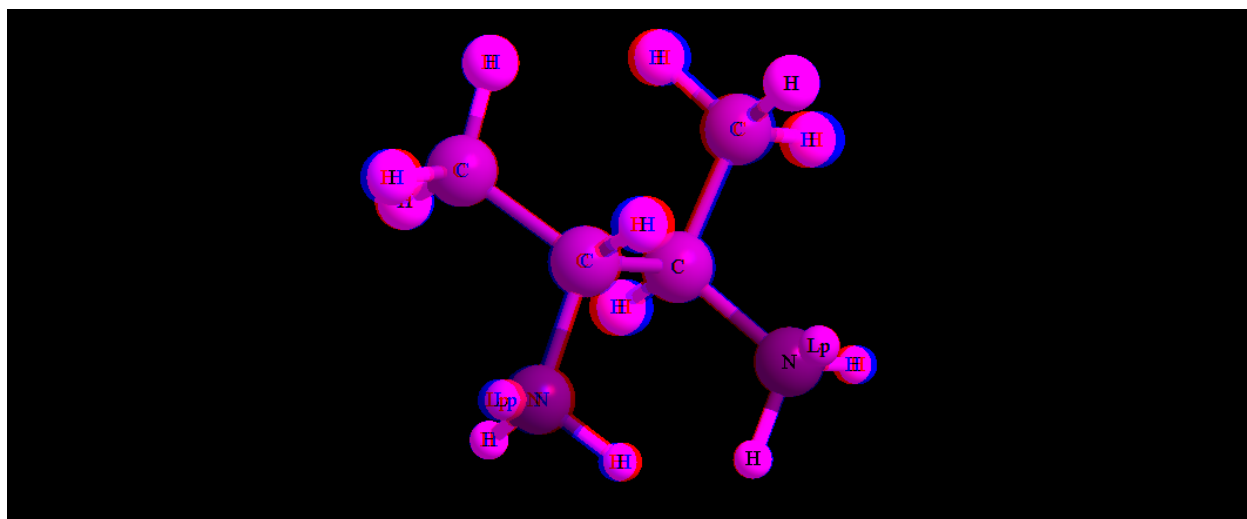

Symmetrical Bidentate Ligand (AA): $\text{NH}_2\text{CH}(\text{CH}_3)\text{CH}(\text{CH}_3)\text{NH}_2$

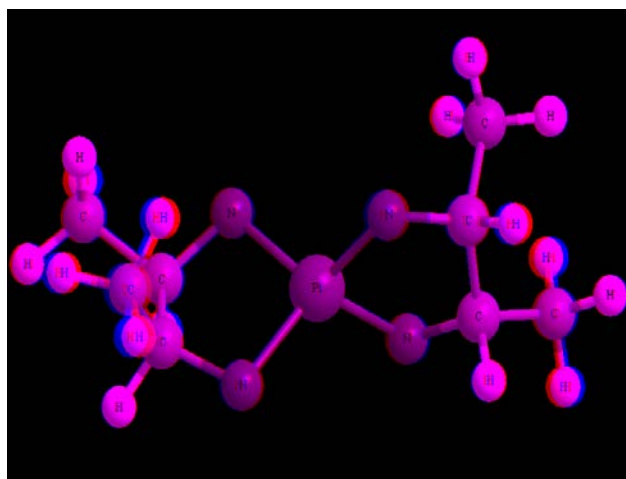

$\text{cis-}[\text{Pt}(\text{NH}_2\text{CH}(\text{CH}_3)\text{CH}(\text{CH}_3)\text{NH}_2)_2]^{+2}$

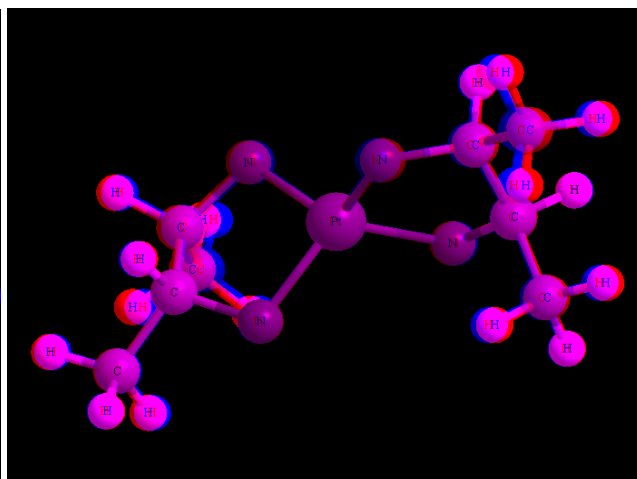

$\text{trans-}[\text{Pt}(\text{NH}_2\text{CH}(\text{CH}_3)\text{CH}(\text{CH}_3)\text{NH}_2)_2]^{+2}$

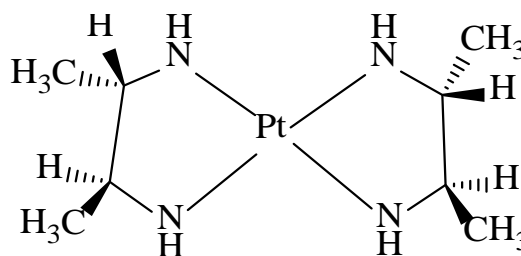
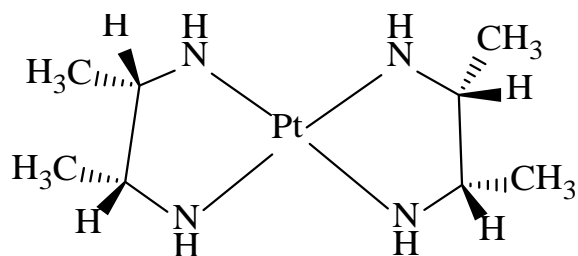

(View movie: [flv 1/cis-\[Pt\(NH2CH\(CH3\)CH\(CH3\)NH2\)2\]+2.flv](#),

[flv 1\trans-\[Pt\(NH2CH\(CH3\)CH\(CH3\)NH2\)2\]+2.flv](#)

IV. Bridged binuclear planar complexes

i. $M_2a_2b_4$ type:

In this type of complexes cis and trans isomers as well as the unsymmetrical form also exist as shown below.

e.g. $[Pt(PEt_3)Cl_2]_2$

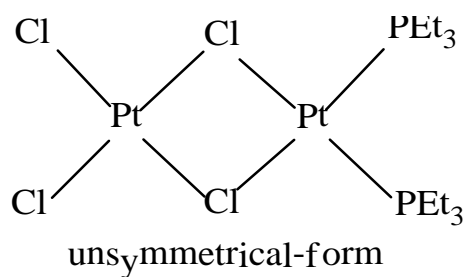
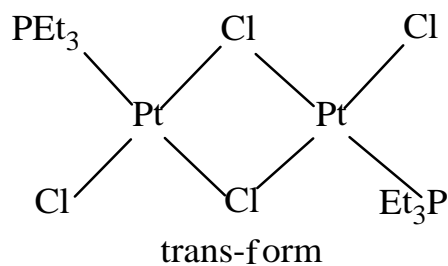
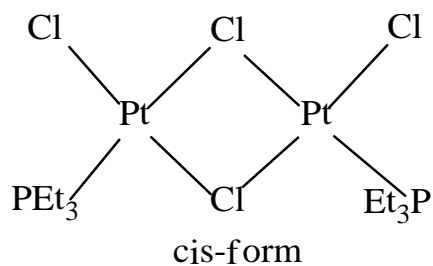

LECTURE #19

2. Geometrical isomerism: 6-Coordinate complexes

6-Coordination is the most common and hence the most extensively studied coordination in coordination chemistry. Three possible arrangements of six ligands around the central metal ion are possible

Hexagonal planar

Trigonal prismatic

Octahedral

The physical and chemical evidences, especially those based on isomerism have shown that the arrangement of six ligands in a 6-coordinate complex is always octahedral with all six positions equivalent.

The arrangement of six ligands in a regular octahedral complex around the central metal ion can be represented as shown below:

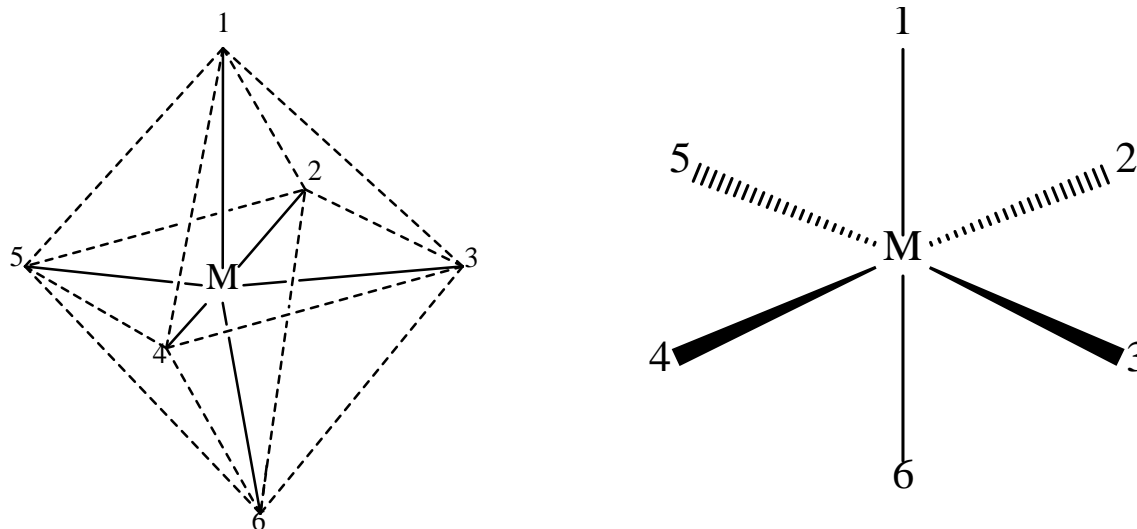

I. Octahedral complexes containing monodentate ligands:

In these complexes; $[Ma_6]^{\pm n}$, $[Ma_5b]^{\pm n}$ and $[Mab_5]^{\pm n}$ types do not show geometrical isomerism.

Following types show geometrical isomerism.

i. $[Ma_4b_2]^{\pm n}$ type:

In this type of complexes two 'b' ligands have adjacent position for cis isomers, while in trans form two 'b' ligands are diagonally opposite to each other as shown below.

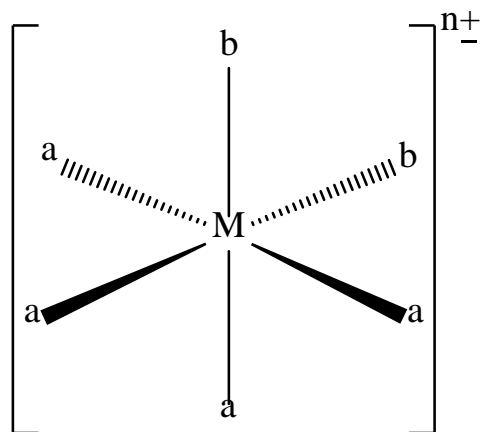

cis-form

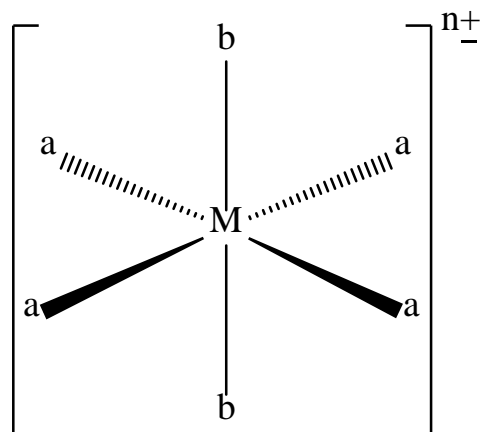

trans-form

It means in cis form 'b' ligands lie on any of the twelve edges of the octahedron and in trans form 'b' ligands are at end of the straight line passes through the central atom.

$[\text{Co}(\text{NH}_3)_4\text{Cl}_2]^+$ is a well-known example for this type. In cis isomers, two Cl^- ions are at the adjacent position (i.e. 1,2-position), while in trans isomers two Cl^- ions are opposite to each other (i.e. 1,6-position) as shown below.

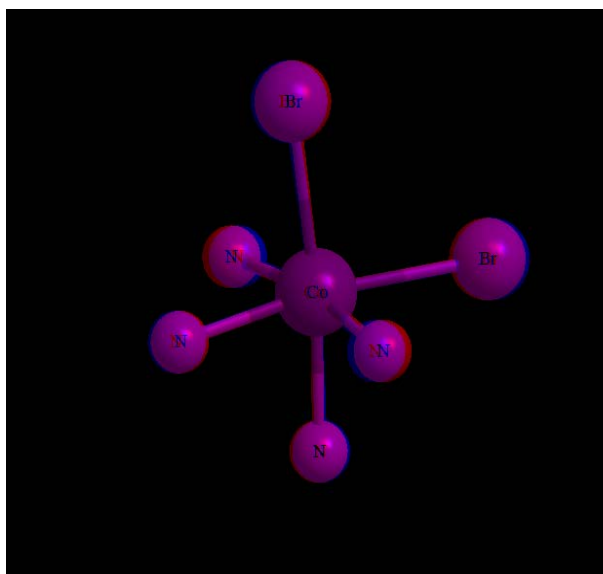

cis-form or (1,2)-isomer

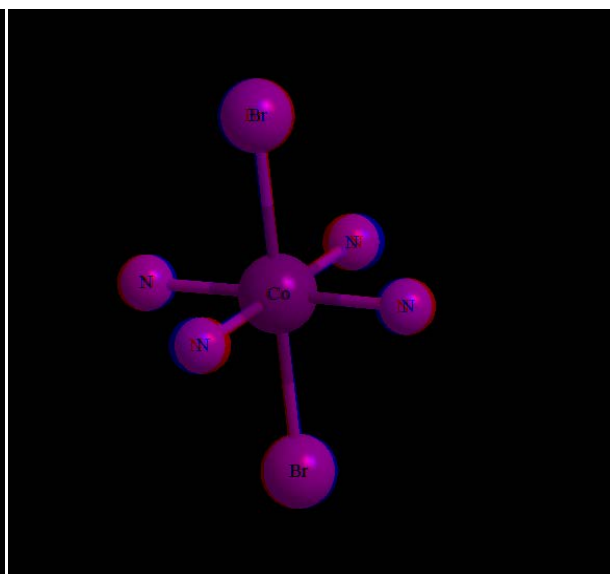

trans-form or (1,6)-isomer

(View Movie: [flv 1\cis-form or \(1,2\)-isomer.flv](#), [flv 1\trans-form or \(1,6\)-isomer.flv](#))

ii. $[Ma_3b_3]^{n\pm}$ type:

Two isomers exist (i.e. cis & trans) as shown below

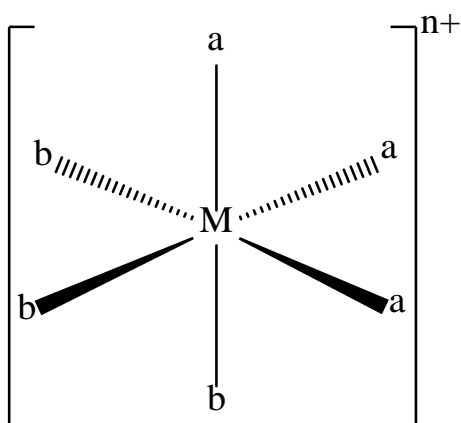

cis-form or (1,2,3-isomer)

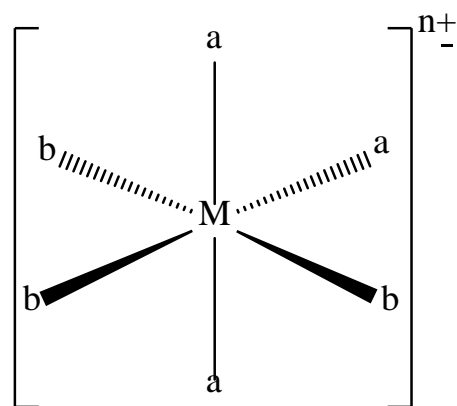

trans-form or (1,2,6-isomer)

In cis isomers, three 'a' occupy 1, 2 and 3 positions while in trans isomers, they occupy 1, 2 and 6 positions.

e.g. $[\text{Cr}(\text{NH}_3)_3\text{Cl}_3]$, $[\text{Rh}(\text{py})_3\text{Cl}_3]$

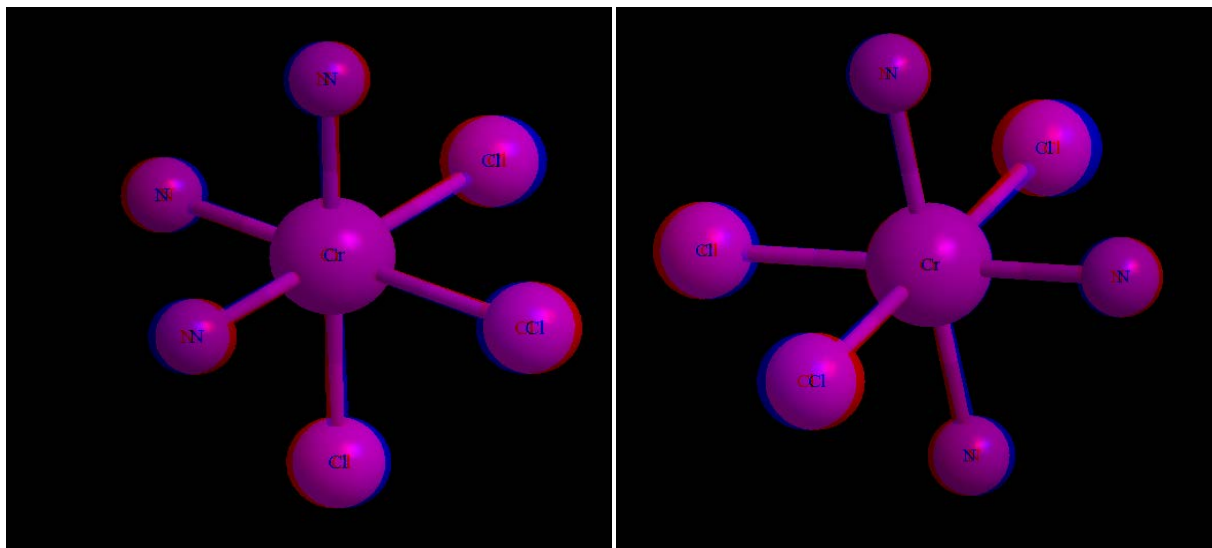

cis- $[\text{Cr}(\text{NH}_3)_3\text{Cl}_3]$ OR fac- $[\text{Cr}(\text{NH}_3)_3\text{Cl}_3]$

trans- $[\text{Cr}(\text{NH}_3)_3\text{Cl}_3]$ OR mer- $[\text{Cr}(\text{NH}_3)_3\text{Cl}_3]$

(View Movie: [flv 1\cis-\[Cr\(NH3\)3Cl3\]OR fac-\[Cr\(NH3\)3Cl3\].flv](#),

[flv 1\trans-\[Cr\(NH3\)3Cl3\]OR mer-\[Cr\(NH3\)3Cl3\].flv](#))

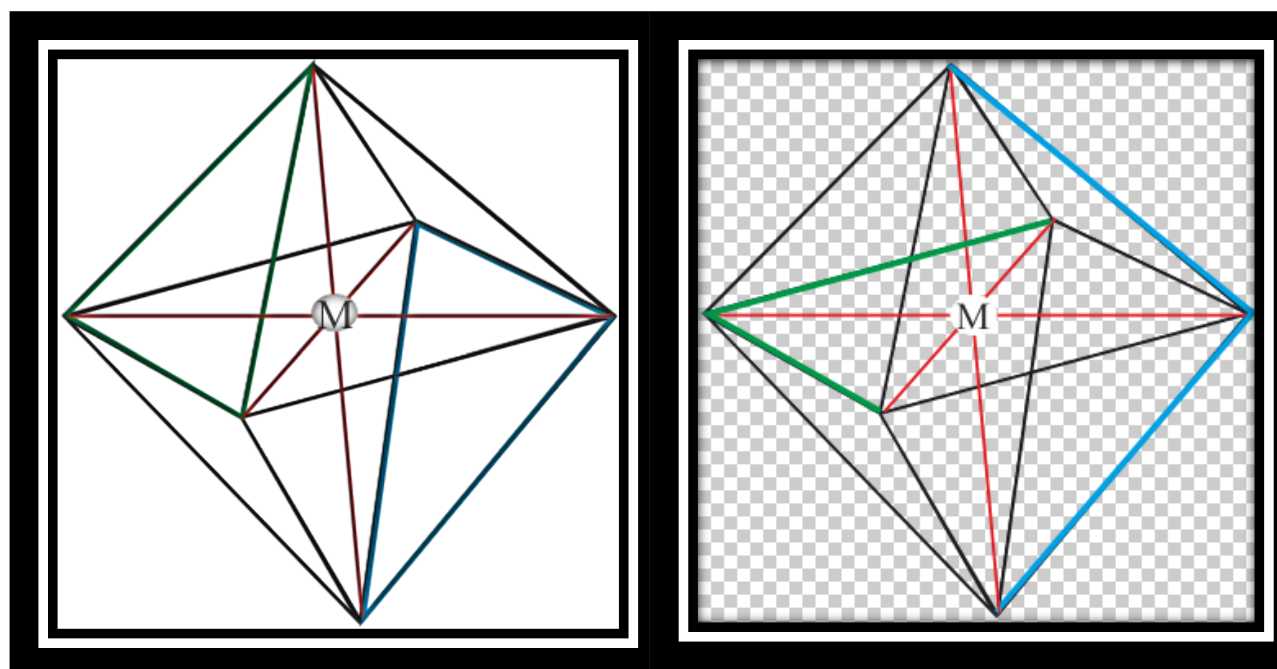

facial arrangement

meridional arrangement

In cis isomer, three Cl^- ions are on the triangular face of the octahedron and three NH_3 molecules are on the opposite triangular face of the octahedron hence is called facial isomer.

In trans isomer, three Cl^- ions are around the edge of the octahedron and three NH_3 molecules are at the opposite edge of the octahedron, hence is called peripheral isomer.

iii. $[\text{Mabcdef}]^{\pm n}$ type:

In this type of complexes, there are 15 different geometrical isomers in which all have optical isomers. Only one compound known is $[\text{Pt}(\text{py})(\text{NH}_3)(\text{NO}_2)\text{ClBrI}]$. In this compound only three forms are obtained but no attempt has been made to isolate all the 15 isomers.

II. Octahedral complexes containing monodentate and symmetrical bidentate ligands:I. $[M(AA)_2a_2]^{n\pm}$ type:

Here (AA) is a symmetrical bidentate chelating ligand having ends A. Cis and trans forms are shown below.

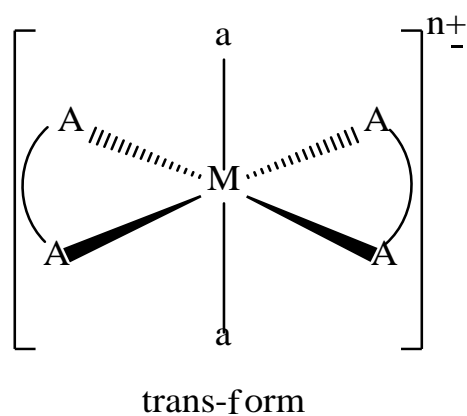
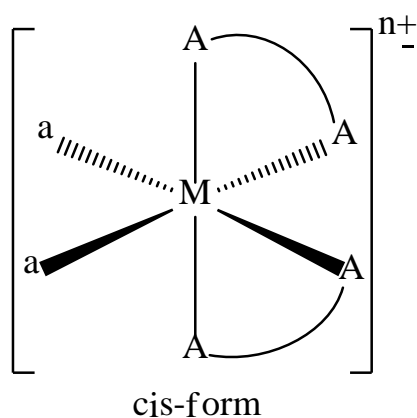

In cis isomer, 'a' are cis to each other and in trans isomers 'a' are trans to each other.

e.g. $[\text{Co}(\text{en})_2(\text{NO}_2)_2]^+$, $[\text{Ir}(\text{C}_2\text{O}_4)_2\text{Cl}_2]^{2-}$, $[\text{Rf}(\text{C}_2\text{O}_4)_2\text{Cl}_2]^{2-}$, $[\text{Cr}(\text{C}_2\text{O}_4)_2(\text{H}_2\text{O})_2]^-$ etc.

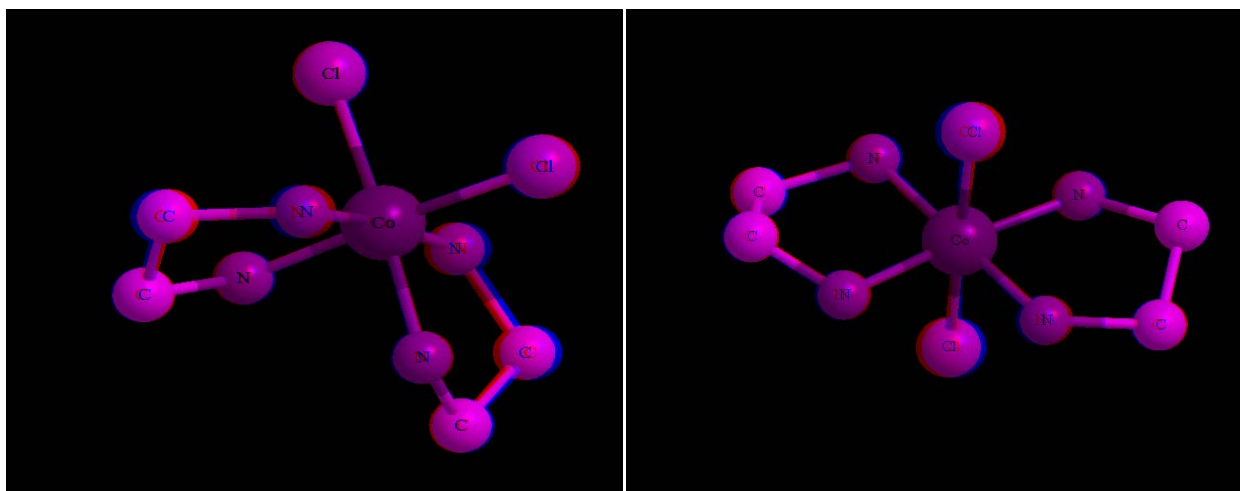

cis-[Co(en)₂(Cl)₂]⁺

trans-[Co(en)₂(Cl)₂]⁺

(View Movie: [flv 1\cis-\[Co\(en\)2\(Cl\)2\]+.flv](#), [flv 1\trans-\[Co\(en\)2\(Cl\)2\]+.flv](#))

In cis isomer two Cl⁻ ions are cis to each other and trans isomers two Cl⁻ ions are trans to each other.

II. [M(AA)₂ab]^{±n} type:

Following geometrical isomers exist

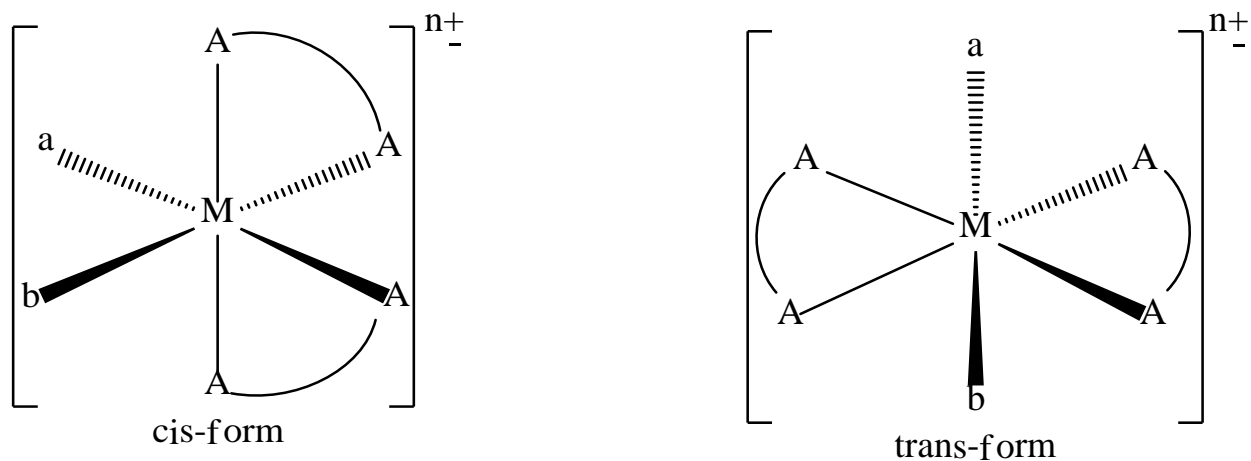

e.g. $[\text{Co}(\text{en})_2(\text{NH}_3)\text{Cl}]^{2+}$, $[\text{Ru}(\text{py})(\text{C}_2\text{O}_4)_2(\text{NO})]$ etc.

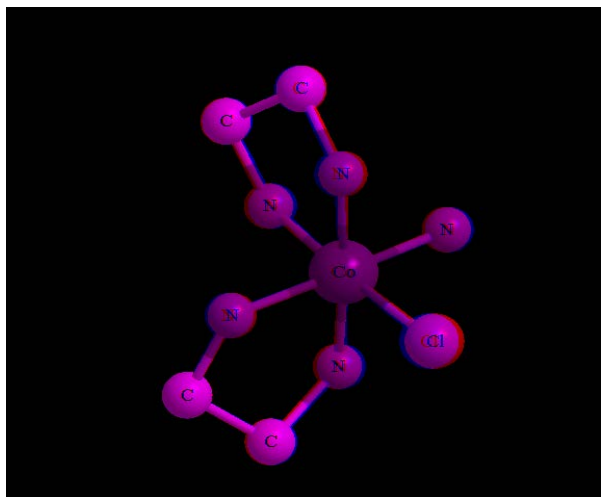

cis- $[\text{Co}(\text{en})_2(\text{NH}_3)\text{Cl}]^{2+}$

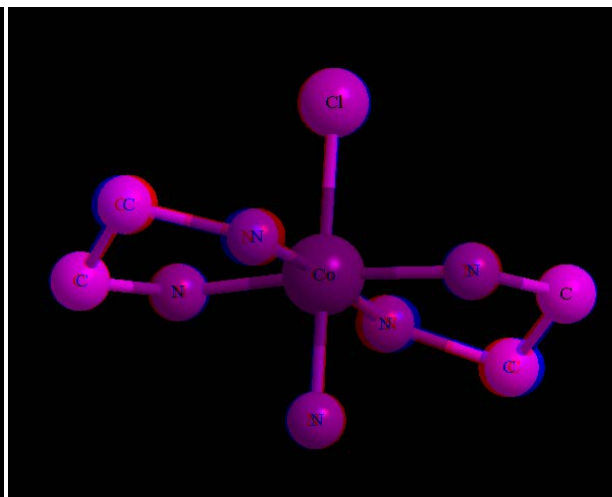

trans- $[\text{Co}(\text{en})_2(\text{NH}_3)\text{Cl}]^{2+}$

(View Movie: [flv 1\cis-\[Co\(en\)2\(NH3\)Cl\]2+.flv](#), [flv 1\trans-\[Co\(en\)2\(NH3\)Cl\]2+.flv](#))

III. $[\text{M}(\text{AA})_2\text{b}_2]^{±n}$ type:

Following geometrical isomers exist.

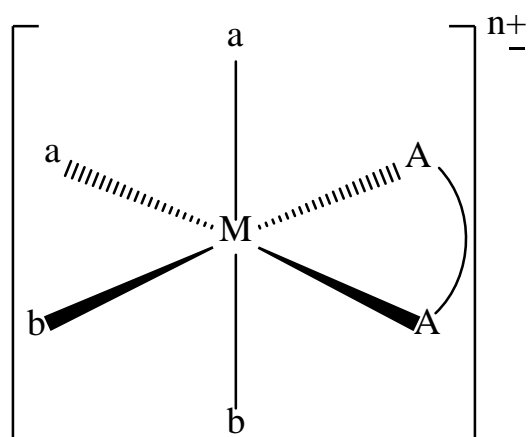

cis-form

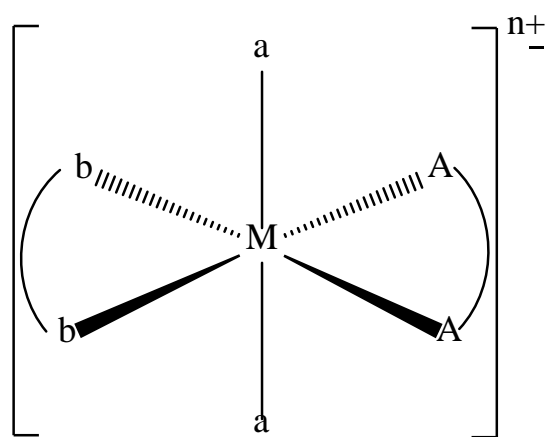

trans-form

e.g. $[\text{Co}(\text{en})(\text{NH}_3)_2\text{Cl}_2]^{2+}$

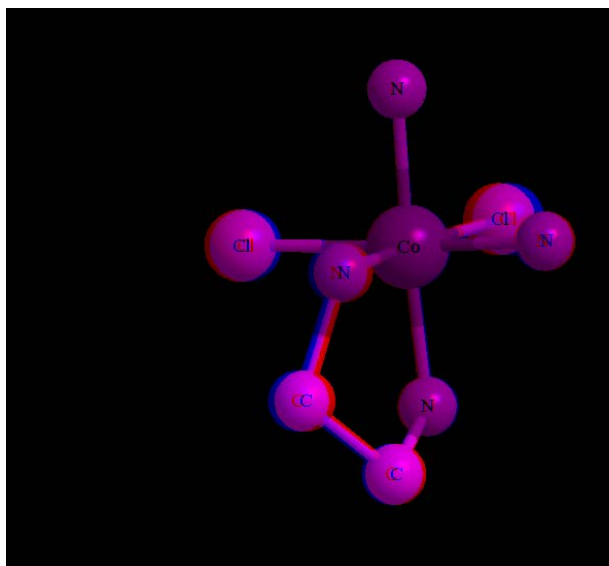

cis- $[\text{Co}(\text{en})(\text{NH}_3)_2\text{Cl}_2]^{2+}$

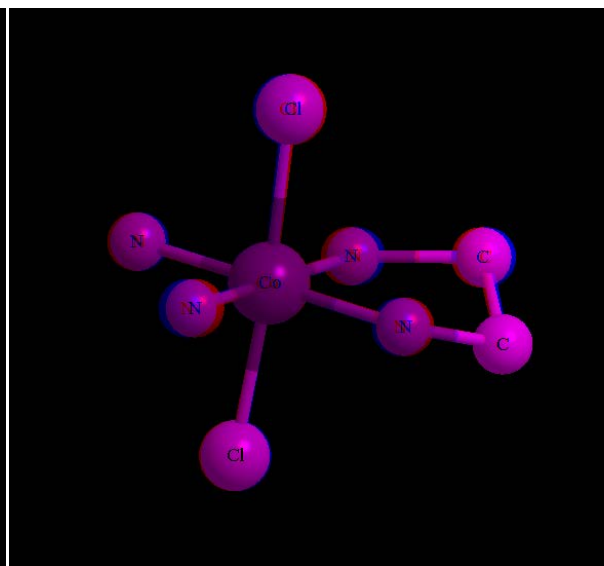

trans- $[\text{Co}(\text{en})(\text{NH}_3)_2\text{Cl}_2]^{2+}$

(View Movie: [flv 1\cis-\[Co\(en\)\(NH3\)2Cl2\]2+.flv](#), [flv 1\trans-\[Co\(en\)\(NH3\)2Cl2\]2+.flv](#))

IV. Octahedral Complexes containing unsymmetrical bidentate chelating ligands:

1. $[M(AB)_3]^{±n}$ type:

In this type AB is unsymmetrical bidentate chelating ligand which is having A and B two ends as shown below.

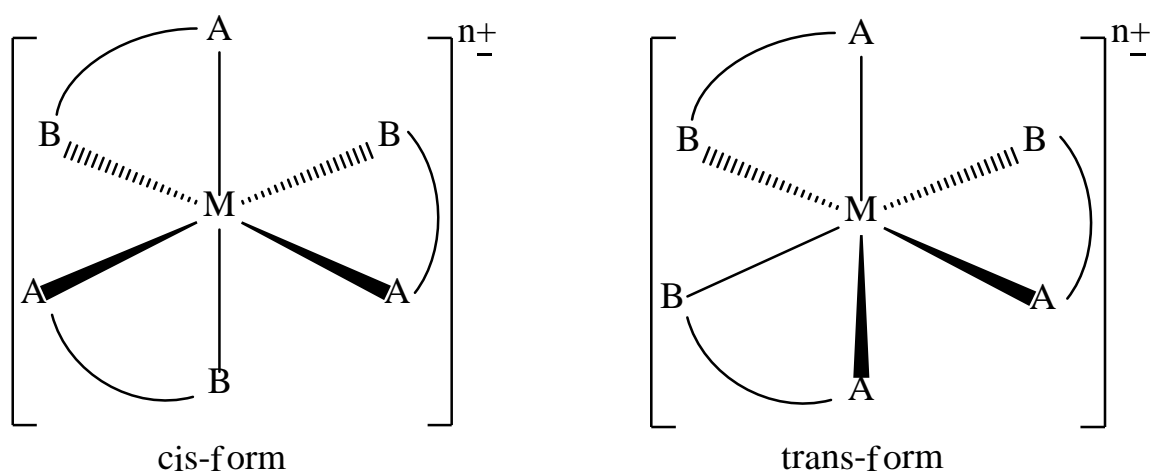

e.g. $[Cr(gly)_3]$

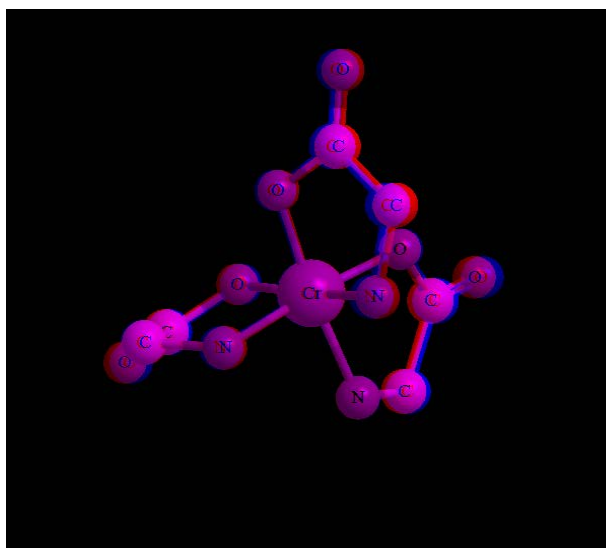

cis-[Cr(gly)₃]

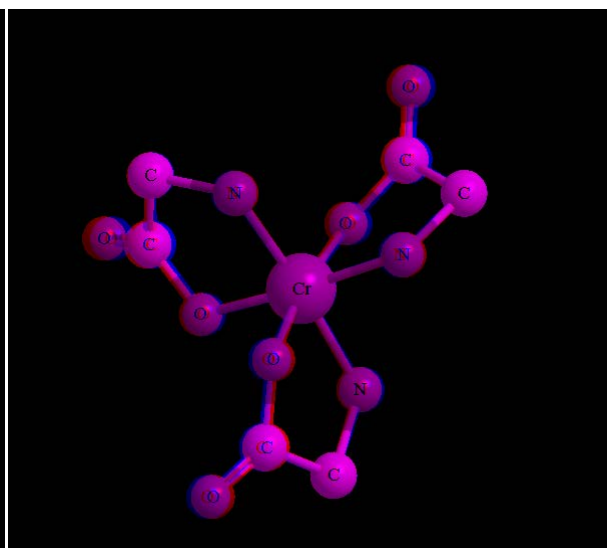

trans-[Cr(gly)₃]

(View Movie: [flv 1\cis-\[Cr\(gly\)3\].flv](#), [flv 1\trans-\[Cr\(gly\)3\].flv](#))

LECTURE #20**5. MAXIMUM NUMBER OF GEOMETRICAL ISOMERS IN DIFFERENT COMPLEXES:**

Owing to various geometries and a wide variety of ligands, a detailed treatise on all types of complexes is avoided. However, a table shown below can provide a guidance to study isomerism any many other complexes. A student should prepare the hypothetical molecules and sketch the possible isomers for the complexes shown in the table.

<i>Formula</i>	<i>Geometry</i>	<i>Maximum Number of geometrical isomers</i>
Ma_4	Tetrahedral	1
$Mabcd$		1
Ma_4	Square planar	1
Ma_3b		1
Ma_2b_2		2
Ma_2bc		2
$Mabcd$		3
$M(AA)_2$		2
$M(AB)_2$		2
$M_2A_2B_4$		3

Ma_6	Octahedral	1
Ma_5b		1
Ma_4b_2		2
Ma_3b_3		2
Ma_4bc		2
Ma_3bcd		5
Ma_2bcde		15
$Mabcdef$		30
$Ma_2b_2c_2$		6
Ma_2b_2cd		8
Ma_3b_2c		3
$M(AA)_2a_2$		2
$M(AA)_2ab$		2
$M(AA)a_2b_2$		2
$M(AA)(BC)de$		10
$M(AB)(AB)cd$		11

$M(AB)(CD)ef$	20
$M(AB)_3$	2
$M(ABA)cde$	9
$M(ABC)_2$	11
$M(ABBA)cd$	7
$M(ABCBA)d$	7

LECTURE #21

6. EXPERIMENTAL SEPARATION AND IDENTIFICATION OF ISOMERS:

1) Dipole moment:

The cis and trans isomers of Pt (II) complexes of the type $[PtA_2X_2]$ type (where A = substituted phosphine, arsine and X = halogen) have been distinguished from their dipole moment values. Since the bond moments in the trans isomer are equal and opposite, the net dipole moment becomes zero. Whereas, the dipole moments for cis isomers in such complexes were observed in the range of 8 to 12 Debye unit. Thus, a non-zero value of dipole moment in the case of square planar complexes of the type $[Ma_2b_2]$ is an indication of cis isomerism while a trans isomer is characterized by zero dipole moment.

2) X-ray crystal analysis:

X-ray crystal analysis is capable of providing more structural information than any other techniques. With a single crystal, it is possible to solve the structure of complexes using X-ray diffraction. Since, electrons diffract the X-rays; the centres of the electron clouds are located using this method. A computer program named Oak Ridge Thermal Ellipsoid Plot (ORTEP) gives the diagram of the complex known as ORTEP diagram. Using ORTEP diagrams, square planarity of several Pt (II) complexes has been confirmed. This arrangement has also been established for four coordinated complexes of Ag (II), Cu (II) and Au (III).

3) IR technique:

The bands in the infrared spectra of the complexes are corresponding to the change in dipole moment of the molecule. The vibrations that do not produce any change in the dipole moment do not show bands. In the trans isomers like $[\text{Co}(\text{NH}_3)_4\text{Cl}_2]^+$ or $[\text{Co}(\text{NH}_3)_2\text{Cl}_2]^+$, the Cl-M-Cl symmetrical stretching vibration do not produce any change in the dipole moment of the molecule. Hence no band corresponding to this vibration is observed in IR spectra.

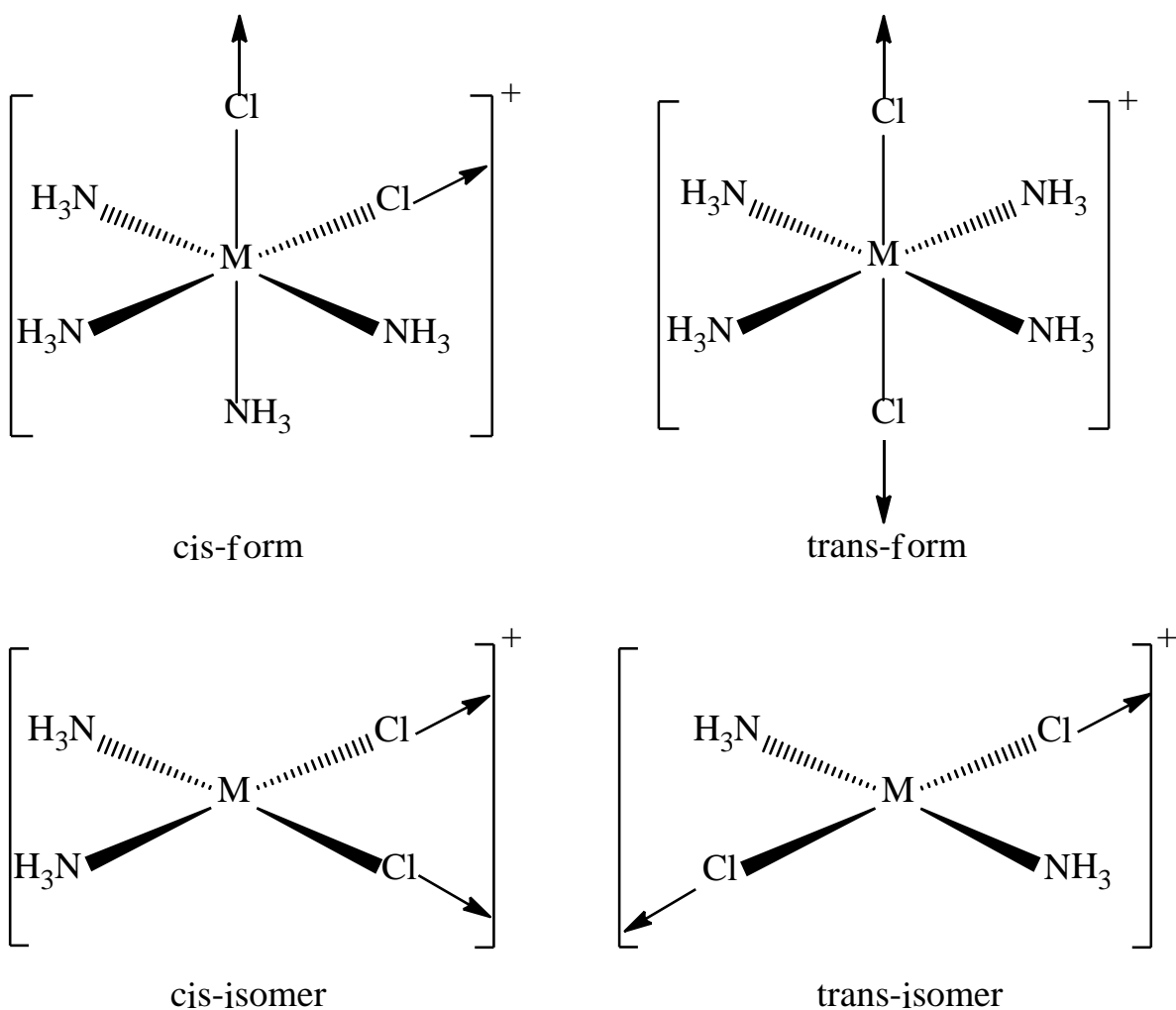

Whereas in the cis isomers, the symmetrical as well as unsymmetrical stretching vibrations produce changes in the dipole moment. Thus, a cis isomer shows a large number of bands due to Cl-M-Cl stretching. An infrared spectrum is thus useful in distinguishing the geometrical isomers of the complexes.

4) Grinberg's method:

It is an important chemical method in which a chelating ligand having two donor atoms is allowed to react with cis and trans isomers separately. With cis isomer, both the donor atoms of chelating ligand coordinate to the central atom forming a chelate with five or six membered ring. Whereas, in case of the trans isomer, the chelating ligand can coordinate to the central atom by only one of the donor atoms. Here it functions as a monodentate ligand and forms an ordinary complex but not chelate.

Oxalic acid (COOH)₂, glycine (H₂N-CH₂-COOH) and ethylenediamine (H₂N-CH₂-CH₂-NH₂) are the most frequent chelating ligands used in this method.

Reactions between cis and trans isomers of [Pt(NH₃)₂Cl₂] and Oxalic acid as well as glycine ligands are shown below:

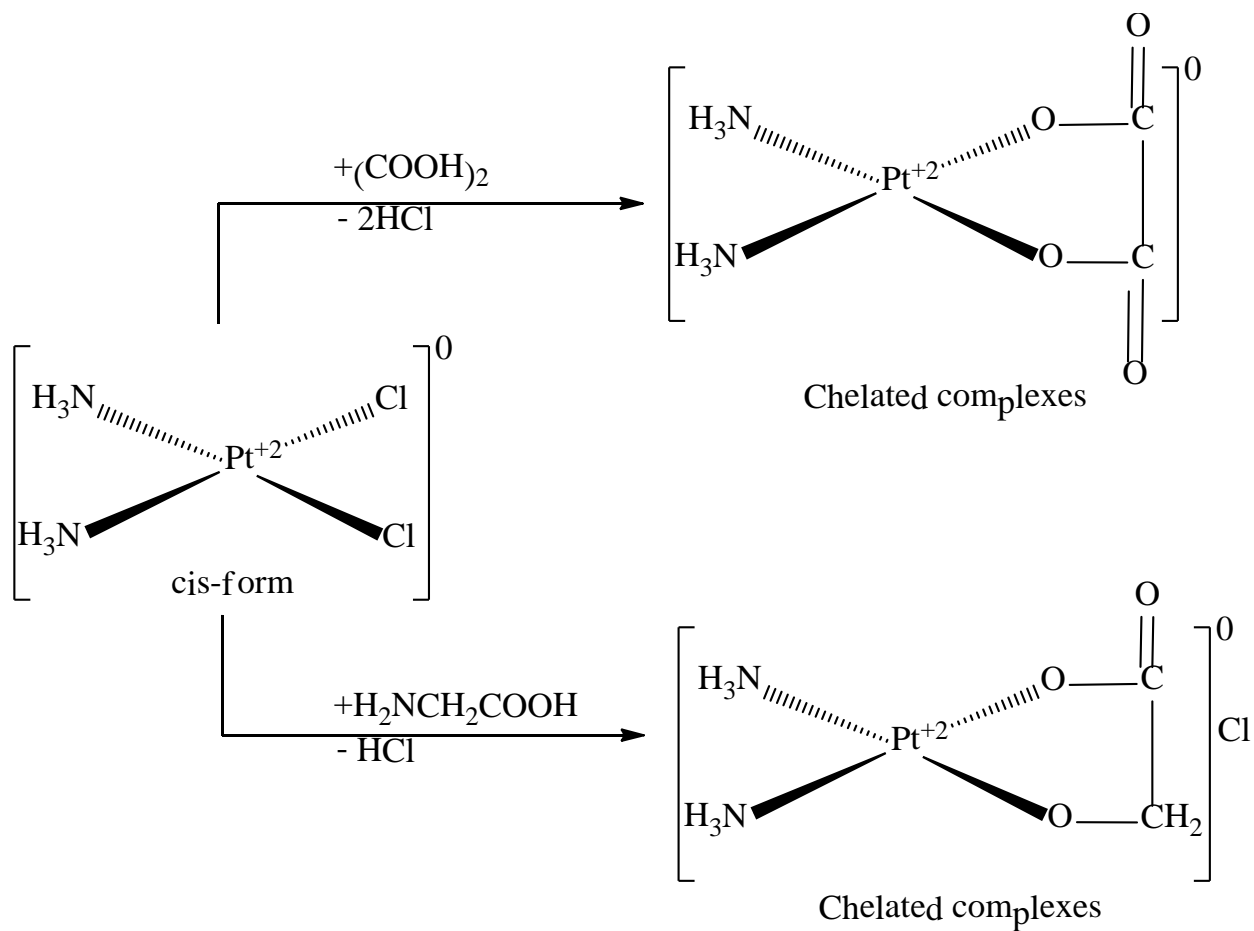

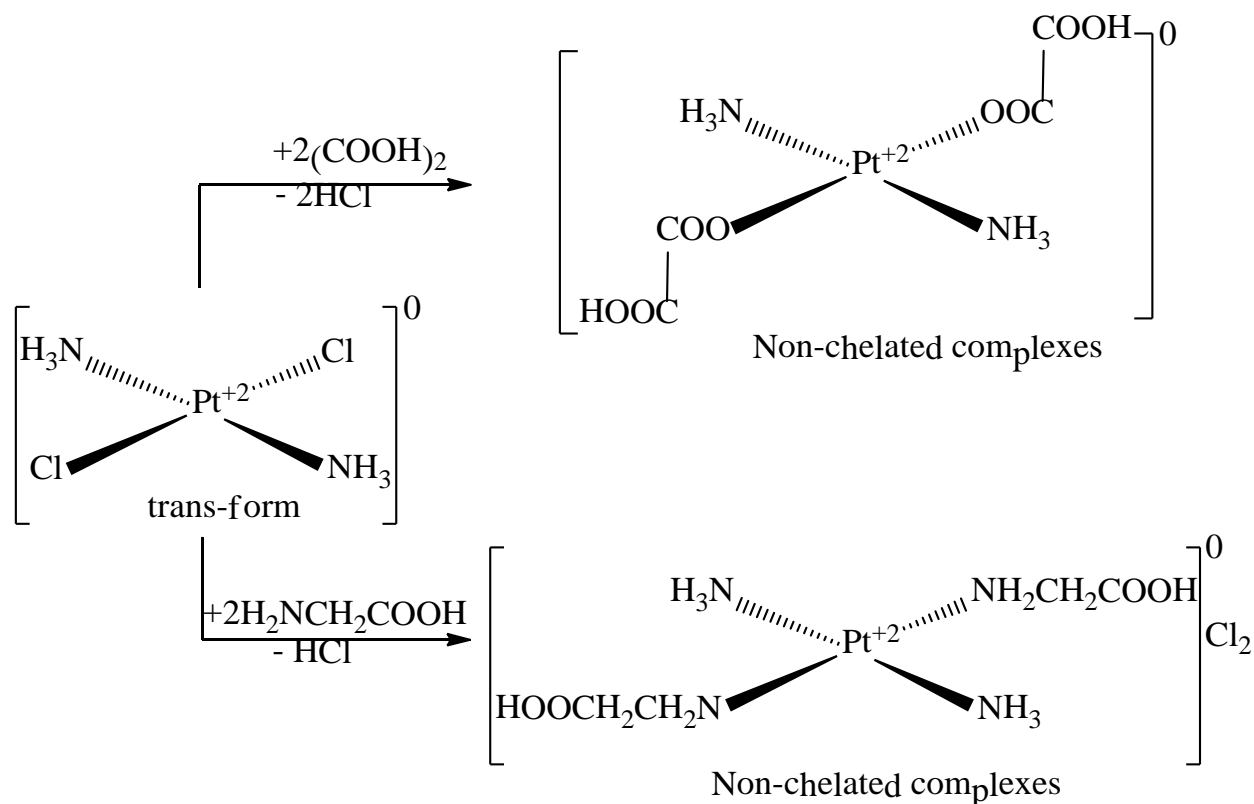

5) Kurnakov's method:

This method is based on the trans directing ability of the ligands. Kurnakov used the phenomena of trans effect in distinguishing the geometrical isomers of square planar complexes of $[\text{PtA}_2\text{X}_2]$ type by treating them with thiourea (th). Here, Pt-N bond is stronger than Pt-Cl bond and the trans directing ability of th is greater than NH_3 .

While reacting a cis isomer of $[\text{Pt}(\text{NH}_3)_2\text{Cl}_2]$ with th, the two weakly bonded chloro ligands get replaced by th in the first step. In the second step, since the th has higher trans directing ability than ammonia, they guide two more th molecules to occupy trans positions with respect to

themselves. Thus, all the four ligands on the substrate gets substituted by thiourea giving $[\text{Pt}(\text{th})_4]$.

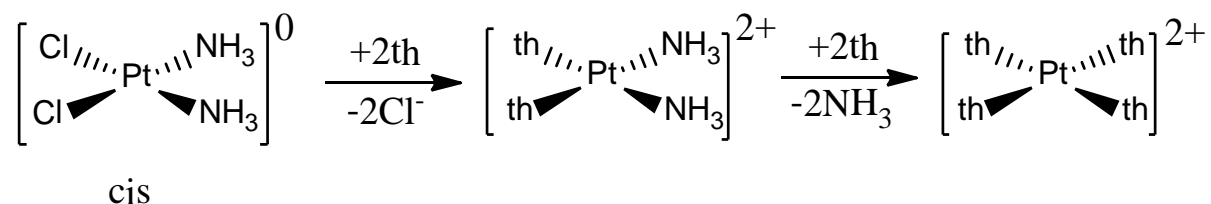

While in case of trans isomer of $[\text{Pt}(\text{NH}_3)_2\text{Cl}_2]$, the two weakly bonded chloro ligands are replaced by th in the first step but in the second step the higher trans effect of th does not allow the ammine ligands to be sufficiently reactive so as to be replaced by the remaining th ligands. Thus, the trans isomer does not permit full substitution by th and gives $[\text{Pt}(\text{NH}_3)_2(\text{th})_2]$.

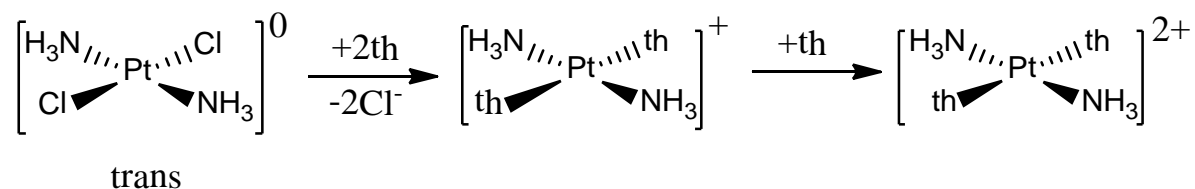

In addition to thiourea, thiosulfate $(\text{S}_2\text{O}_3)^{-2}$ also shows similar reactions with the complexes of type $[\text{PtA}_2\text{X}_2]$.

LECTURE #22**6. OPTICAL ISOMERISM OR MIRROR IMAGE ISOMERISM:**

In order to understand optical isomerism, consider the figure below.

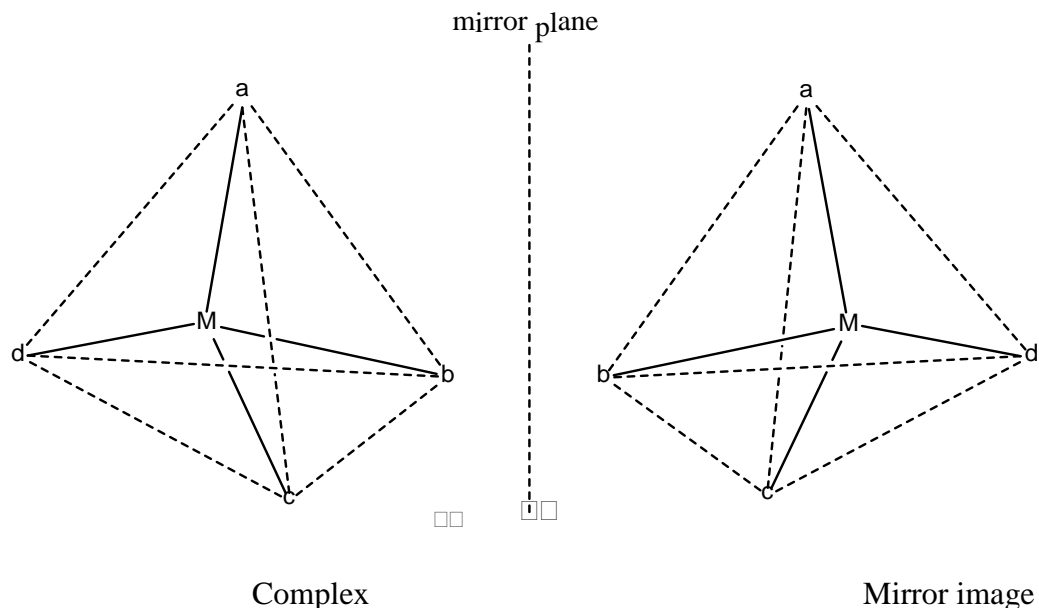

From the figure, it is seen that the complex is not superimposable on its mirror image. The molecules that are not superimposable on their mirror image are called chiral molecules. The reason behind the non-superimposability is the presence of asymmetric bonding on the central metal ion. This asymmetry is characterized by the attachment of all the four different ligands viz. a, b, c and d to the centre. Chiral molecules do not have a plane of symmetry. If a molecule exists in two isomeric forms, which are mirror images of each other and are not superimposable over one another, the pair of such isomers is called enantiomers. When such enantiomers have an adequately long lifetime so that they can be separated, the phenomenon of optical isomerism occurs. These isomers are called optical isomers, as they are optically active. While one of the

enantiomer rotates the plane of the polarized light in one direction by a particular angle, the other rotates it in the opposite direction with the same angle. The isomer that rotates the plane of the polarized light towards right side (clockwise direction) is said to be dextro-rotatory or *d*-form. It is also represented by (+) sign. The isomer which rotates plane of polarized light towards left side (anticlockwise direction) is said to be laevo-rotatory or *l*-form. It is also represented by (-) sign. Both isomers have exactly identical physical and chemical properties. A racemic mixture is not capable of rotating the plane polarized light. It contains exactly equal proportion of *d* & *l* forms. In racemic mixture, one form rotates the plane of polarized light in one direction which is balanced by other form in the opposite direction.

1) Optical isomerism in 4-coordinate complexes:

Square planar complexes

Optical isomerism is not possible in any type of square planar complexes as they possess at least one plane of symmetry (molecular plane). However, in one of the rare case, a complex $[\text{Pt}(\text{NH}_2\text{CH}(\text{C}_6\text{H}_5)\text{CH}(\text{C}_6\text{H}_5)(\text{NH}_2)(\text{NH}_2\text{CH}_2\text{C}(\text{CH}_3)_2\text{NH}_2)]\text{Cl}_2$ was resolved into enantiomers. The complex exhibits optical isomerism, which cannot be explained considering tetrahedral geometry.

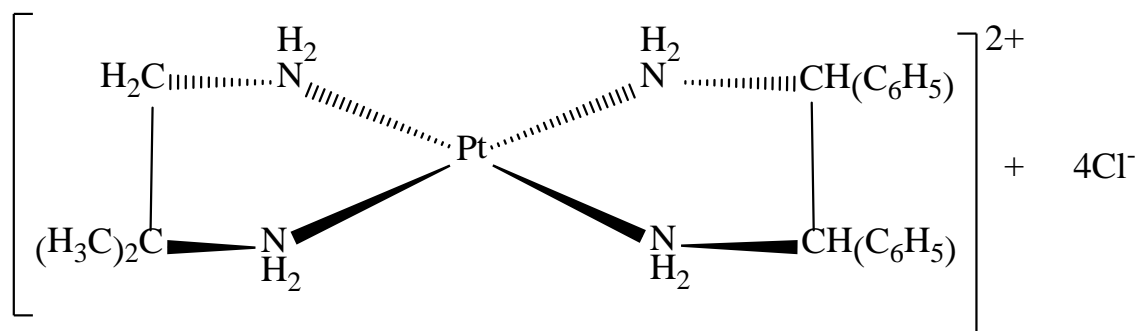

This structure has no plane of symmetry and hence is unsymmetrical and optically active and gives optical isomer.

Tetrahedral complexes:

Only asymmetric tetrahedral molecule characterized by lack of plane of symmetry; [Mabcd] can show optical isomerism.

Optical isomers of As^{+3} ion complex, $[\text{As}(\text{CH}_3)(\text{C}_2\text{H}_5)\text{S}(\text{C}_6\text{H}_4\text{COO})]^{+2}$ are shown below:

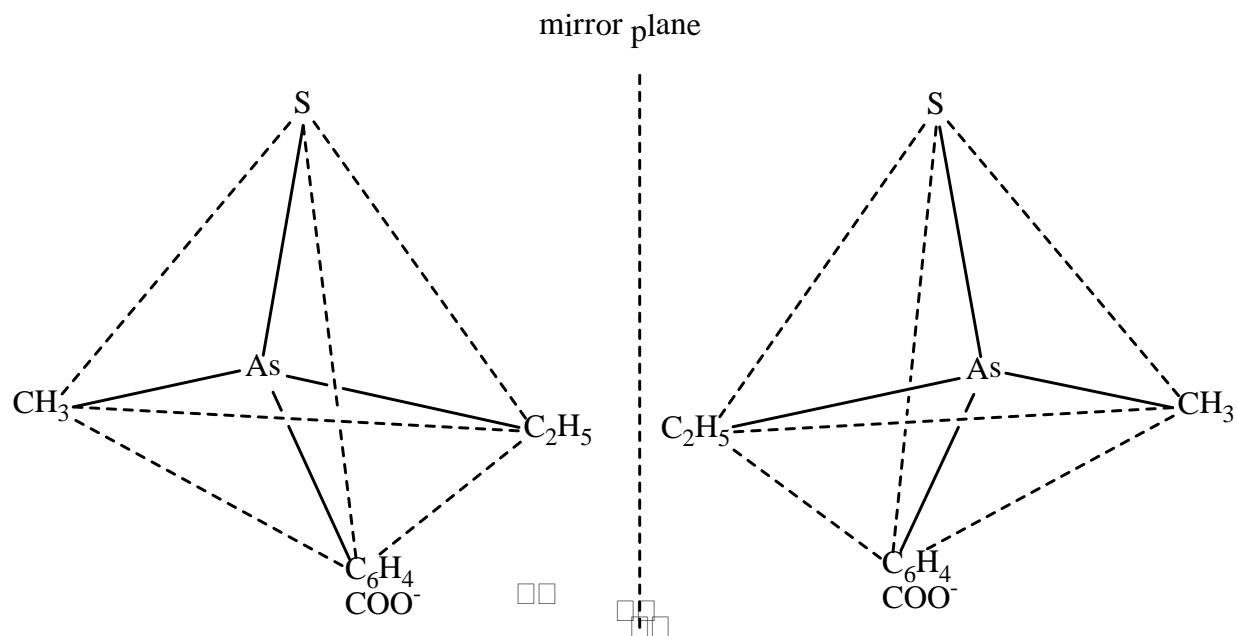
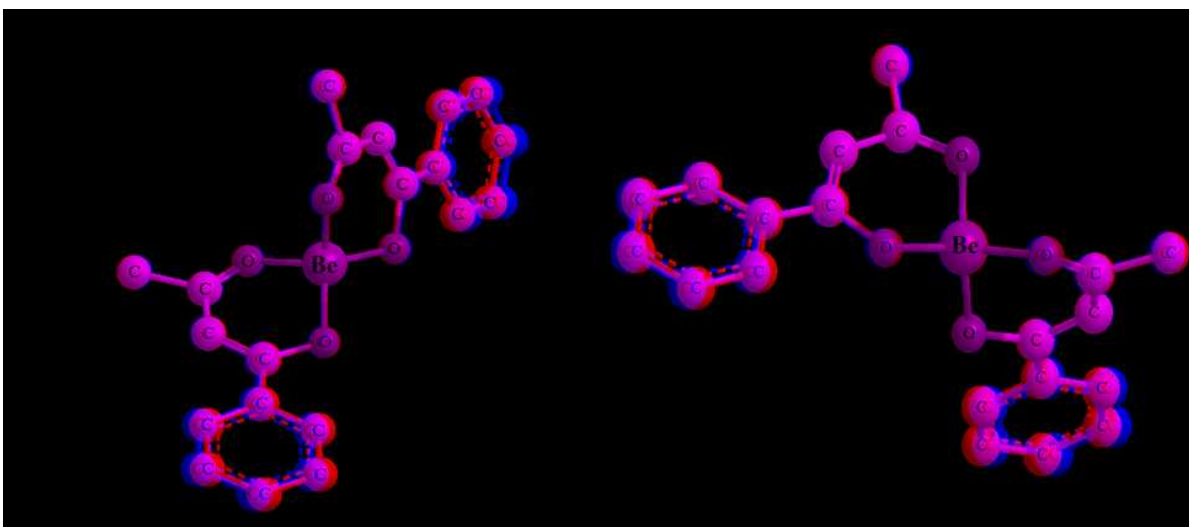

Figure: Optical isomers of $[\text{As}(\text{CH}_3)(\text{C}_2\text{H}_5)\text{S}(\text{C}_6\text{H}_4\text{COO})]^{+2}$

Tetrahedral complexes of Be (II), B (III) and Zn (II) with unsymmetrical bidentate ligands are known to exhibit optical isomerism.

bis(benzoylacetonato)beryllium(II), $[\text{Be}(\text{C}_6\text{H}_5\text{COCHCOCH}_3)_2]$ is an important example of this class.



d-bis(benzoylacetonato)beryllium(II)

l-bis(benzoylacetonato)beryllium(II)

(View Movie: [flv 1\d-bis\(benzoylacetonato\)beryllium\(II\).flv](#),

[flv 1\l-bis\(benzoylacetonato\)beryllium\(II\).flv](#))

In above complex there is no centre or plane of symmetry and are not superimposed on each other. So it will give d- and l- form.

LECTURE #23**2) Optical isomerism in 6-Coordinate complexes:**

The octahedral configuration of the 6-coordinate complex requires the existence not only of the geometrical isomerism of the kind discussed earlier but also of mirror image isomerism leading to optical activity.

Optical activity is very common in the following types of octahedral complexes:

Octahedral complexes containing only monodentate ligands:

i. $[\text{Ma}_2\text{b}_2\text{c}_2]^{\pm n}$ type:

It has two optical isomers as shown below.

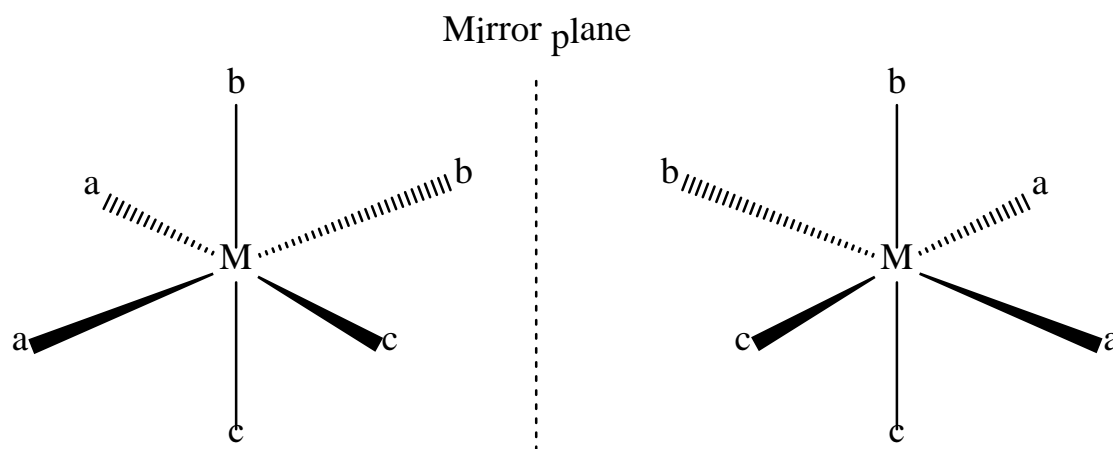

e.g. $[\text{Co}(\text{NH}_3)_2\text{Cl}_2(\text{NO}_2)_2]^{-1}$

ii. $[Mabcdef]^{±n}$ type:

Only Pt(IV) complexes are existing. There are 15 geometrical isomers, each of which could exist in d- and l- form (i.e. each of which a non-superimposable mirror image arises) to give a total of 30 isomers.

For one form of $[Pt(py)(NH_3)(NO_2)(Cl)(Br)(I)]$, the optical isomers are shown below.

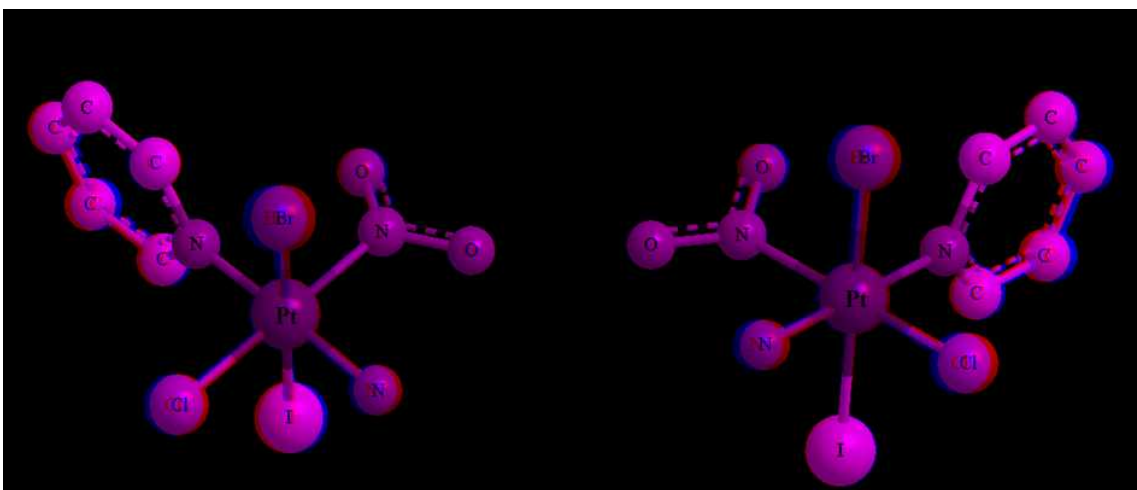

d-isomer

l-isomer

(View Movie: [flv 1\d-isomer.flv](#), [flv 1\l-isomer.flv](#))

Octahedral complexes containing only symmetrical bidentate chelating ligands:

i. $[M(AA)_3]^{±n}$ type:

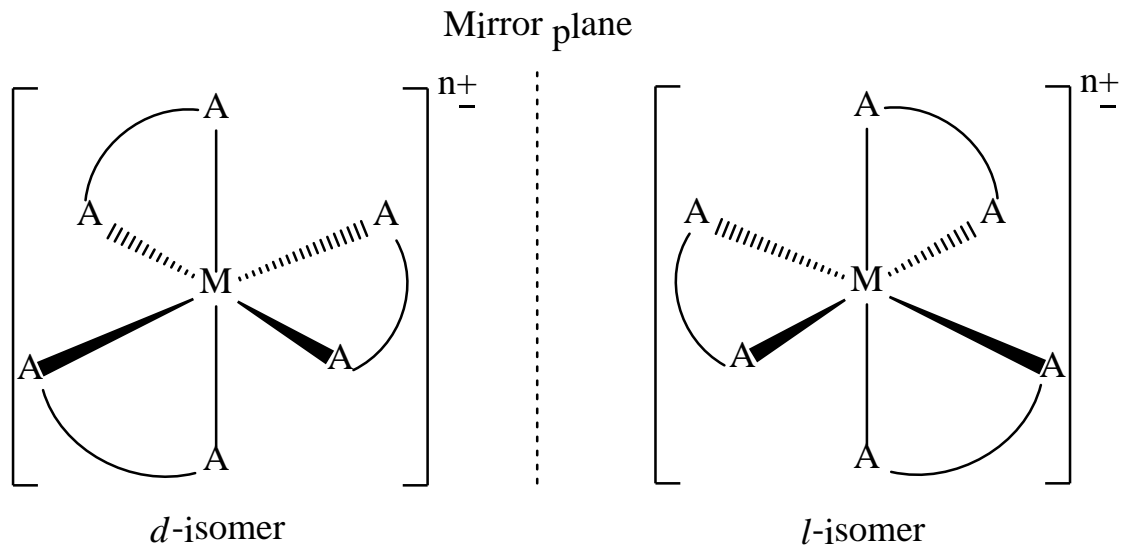

Here AA is a symmetrical bidentate chelating ligand which may be neutral molecule or negative ions.

e.g. $[Co(en)_3]^{+3}$, $[Co(pn)_3]^{+3}$, $[Pt(en)_3]^{+3}$, $[Cr(C_2O_4)_3]^{+3}$, $[Cd(pn)_3]^{+2}$, $[Fe(C_2O_4)_3]^{-3}$

$[Co(en)_3]^{+3}$ give two isomers as shown below.

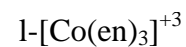
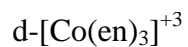
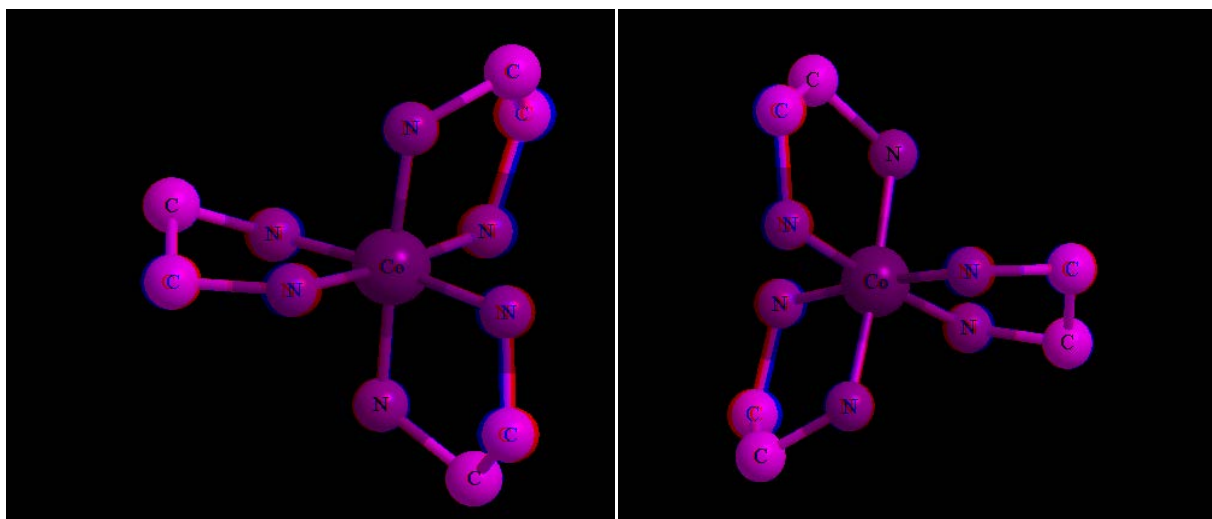

(View Movie: [flv 1\d-\[Co\(en\)3\]+3.flv](#), [flv 1\l-\[Co\(en\)3\]+3.flv](#))

Octahedral complexes containing monodentate and symmetrical bidentate chelating ligands:

1. $[M(AA)_2a_2]^{\pm n}$ type:

Here AA is the symmetrical bidentate chelating and a is the monodentate ligand.

e.g. [Co(en)₂Cl₂]⁺: This complex has two geometrical isomers (i.e. cis-trans isomers). In cis isomer there is no plane of symmetry, hence it show optical active isomer as shown below.

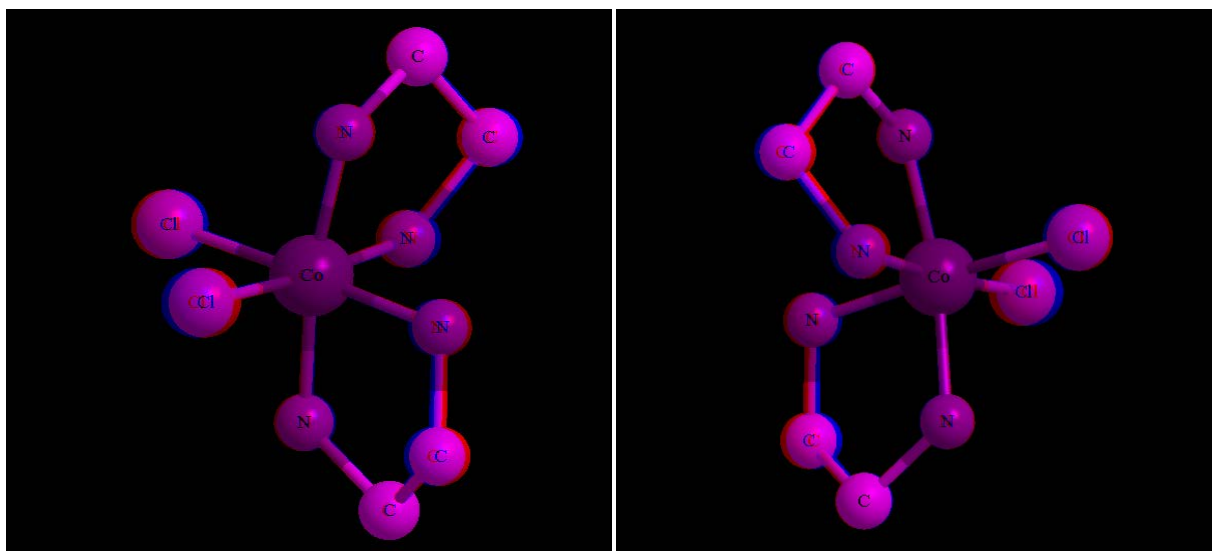

d-cis[Co(en)₂Cl₂]⁺

l-cis[Co(en)₂Cl₂]⁺

(View Movie: [flv 1\d-cis\[Co\(en\)2Cl2\]+.flv](#), [flv 1\l-cis\[Co\(en\)2Cl2\]+.flv](#))

In trans isomer there is plane of symmetry, hence it is optically inactive and show meso form as shown below.

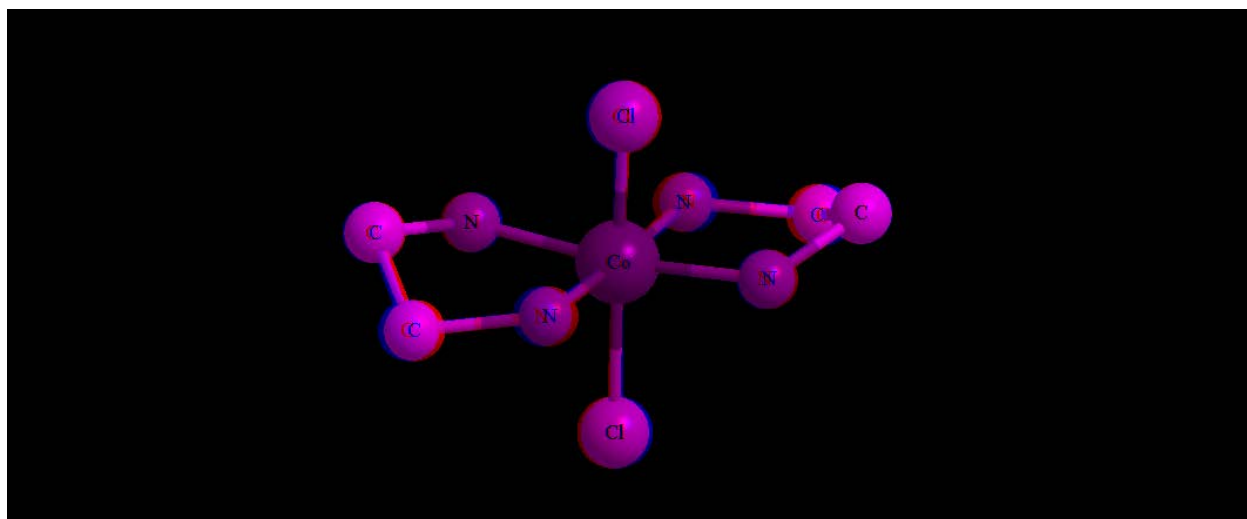

2. $[M(AA)_2ab]^{\pm n}$ type:

These complexes also exist in three forms out of which two forms are optically active and third form is inactive as shown below.

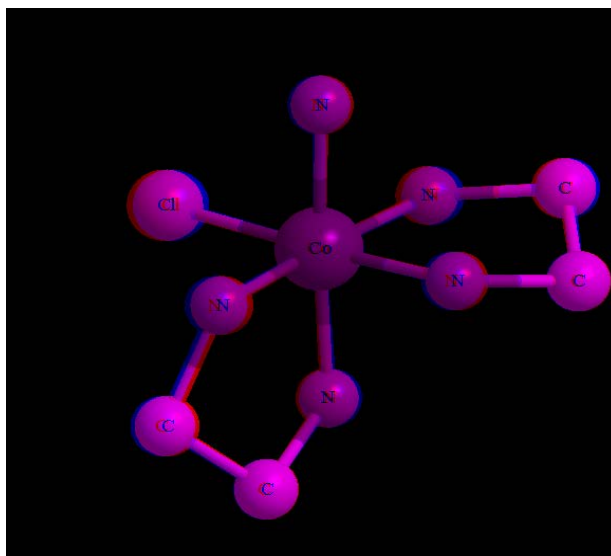

d-[Co(en)₂(NH₃)Cl]

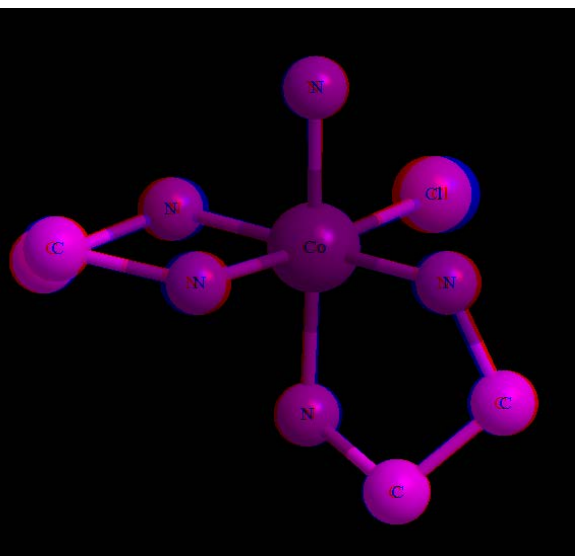

l-[Co(en)₂(NH₃)Cl]

(View Movie: [flv 1\d-\[Co\(en\)2\(NH3\)Cl\].flv](#), [flv 1\l-\[Co\(en\)2\(NH3\)Cl\].flv](#))

3. $[M(AA)_2b_2]^{±n}$ type:

These complexes also exist in three forms out of which two forms are optically active and third form is inactive as shown in below figure.

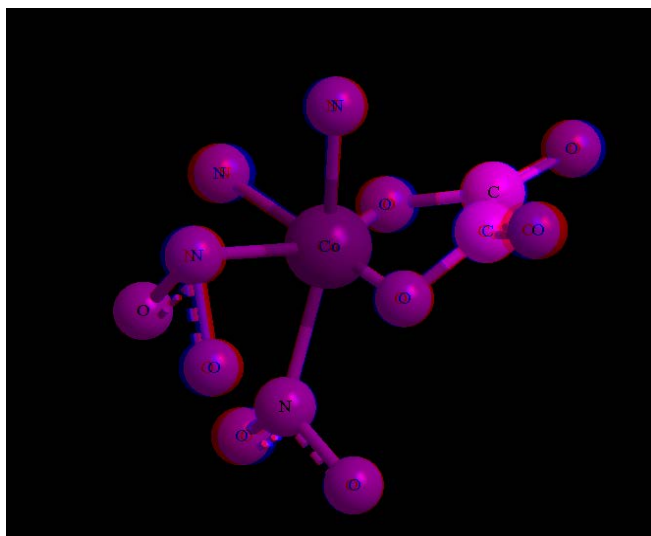

d-cis[Co(C₂O₄)(NH₃)₂(NO₂)₂]

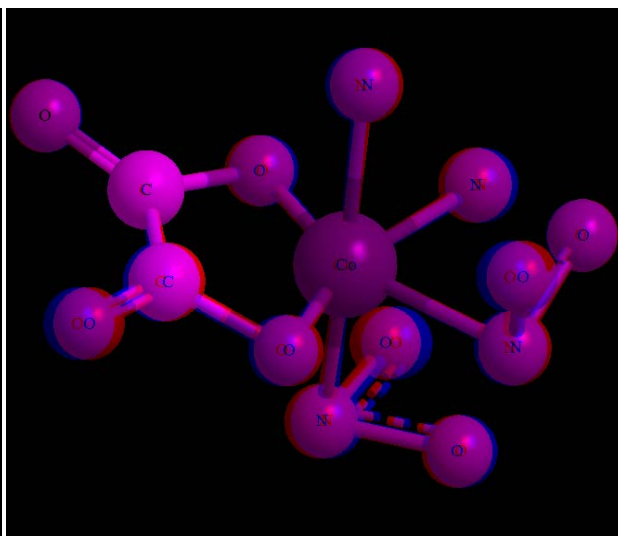

l-cis[Co(C₂O₄)(NH₃)₂(NO₂)₂]

(View Movie: [flv 1\d-cis\[Co\(C2O4\)\(NH3\)2\(NO2\)2\].flv](#),

[flv 1\l-cis\[Co\(C2O4\)\(NH3\)2\(NO2\)2\].flv](#))

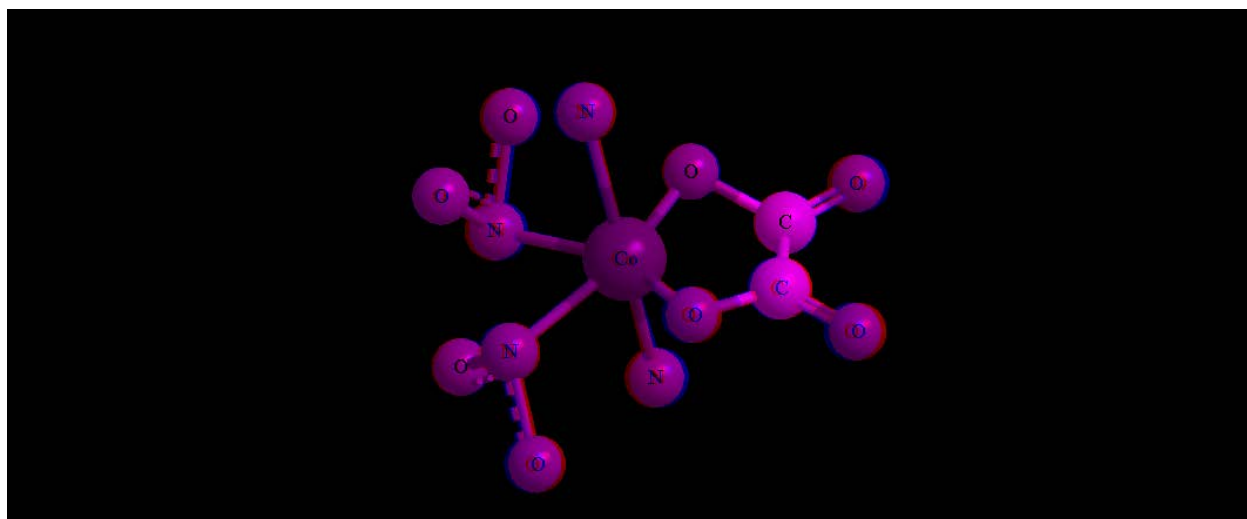

meso-trans[Co(C₂O₄)(NH₃)₂(NO₂)₂]

Octahedral complexes containing optically active ligand:

1,2-diaminopropane (pn) is an unsymmetrical bidentate ligand. The complex [Co(en)(pn)(NO₂)₂]⁺ can form two cis and two trans isomers. Both the cis forms give two optical isomers as shown below.

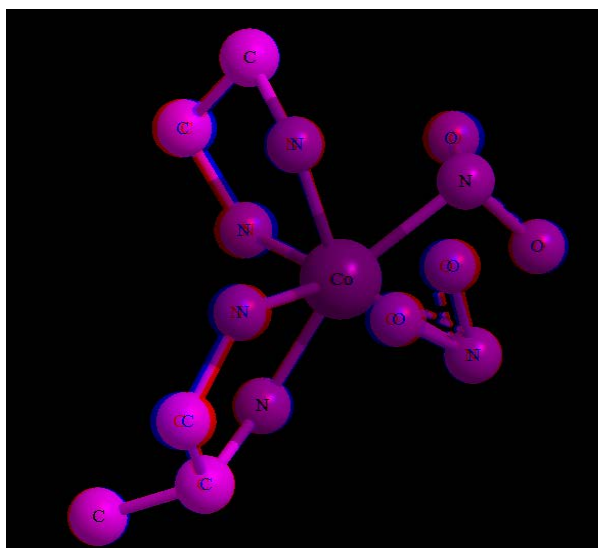

d-cis[Co(en)(pn)(NO₂)₂]⁺

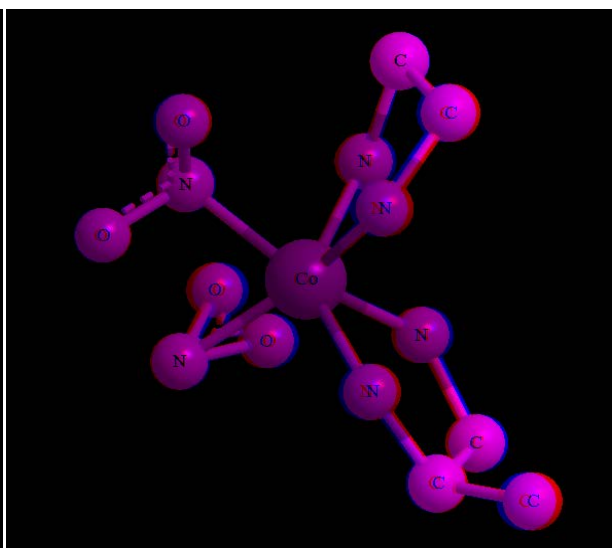

l-cis[Co(en)(pn)(NO₂)₂]⁺

(View Movie: [flv 1\d-cis\[Co\(en\)\(pn\)\(NO2\)2\]+.flv](#), [flv 1\l-cis\[Co\(en\)\(pn\)\(NO2\)2\]+.flv](#))

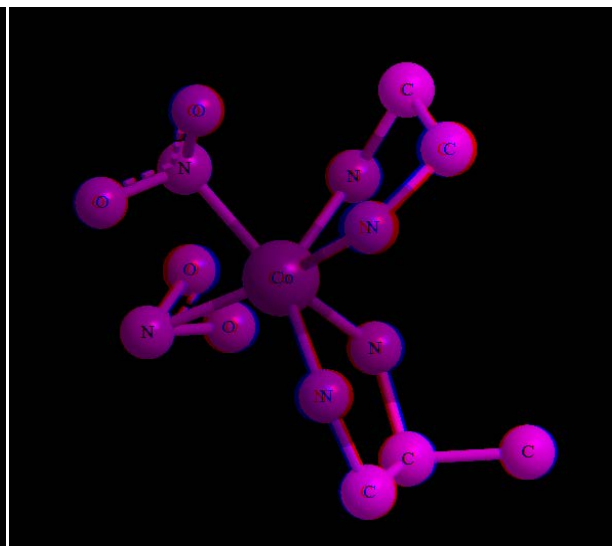
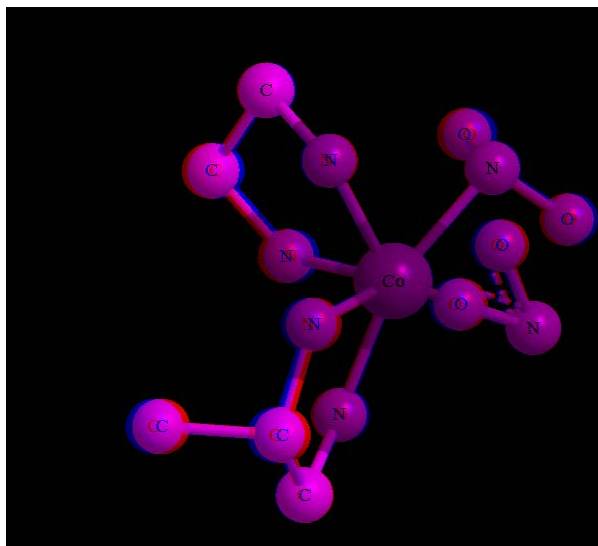

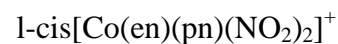
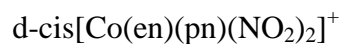

(View Movie: [flv 1\d-cis\[Co\(en\)\(pn\)\(NO2\)2\]+1.flv](#), [flv 1\l-cis\[Co\(en\)\(pn\)\(NO2\)2\]+1.flv](#))

Octahedral complexes containing polydentate ligand:

The structure of Ethylene diamine tetraacetate (edta^{4-}) is a hexadentate ligand is shown below:

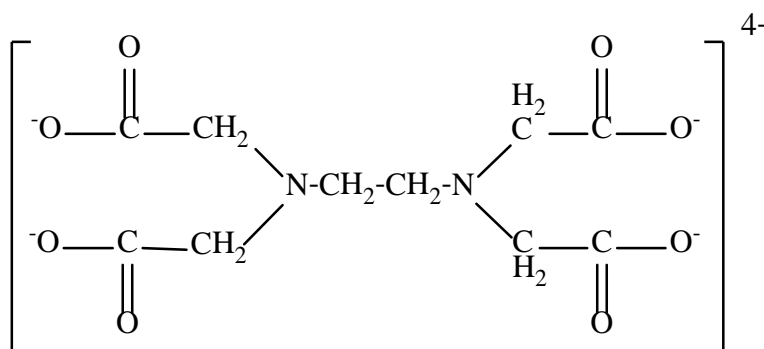

$[\text{Co}(\text{edta})]^-$ exists in two optical isomers (*d*-form and *l*-form) as shown below.

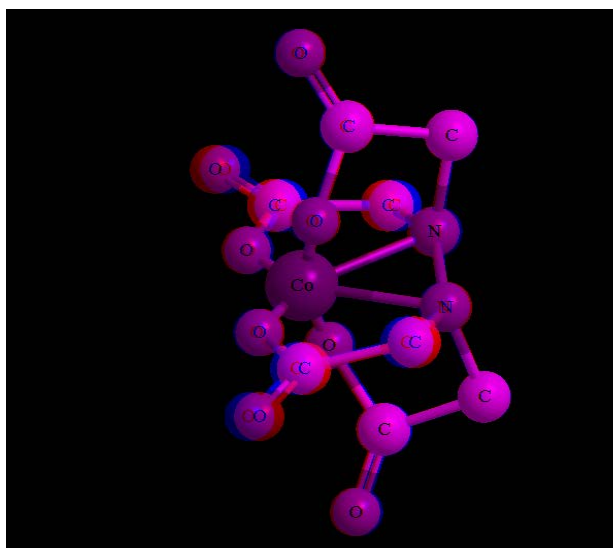

d-[Co(edta)]⁻

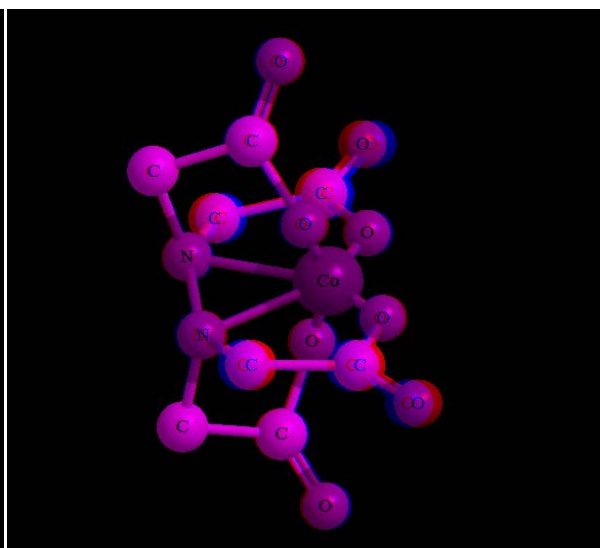

l-[Co(edta)]⁻

(View Movie: [flv 1\d-\[Co\(edta\)\]-.flv](#), [flv 1\l-\[Co\(edta\)\]-.flv](#))

LECTURE #24**7. MAXIMUM NUMBER OF ENANTIOMERIC PAIRS IN DIFFERENT COMPLEXES:**

Owing to various geometries and a wide variety of ligands, a detailed treatise on all types of complexes is avoided. However, a table shown below can provide a guidance to study isomerism any many other complexes.

<i>Formula</i>	<i>Geometry</i>	<i>Number enantiomeric pairs</i>
Ma_4	Tetrahedral	0
$Mabcd$		1
Ma_4	Square planar	0
Ma_3b		0
Ma_2b_2		0
Ma_2bc		0
$Mabcd$		0
$M(AA)_2$		0
$M(AB)_2$		0
$M_2A_2B_4$		0
Ma_6	Octahedral	0
Ma_5b		0

M_4b_2	0
M_3b_3	0
M_4bc	0
M_3bcd	1
M_2bcde	6
$Mabcdef$	15
$M_2b_2c_2$	1
M_2b_2cd	2
M_3b_2c	0
$M(AA)_2a_2$	1
$M(AA)_2ab$	1
$M(AA)a_2b_2$	1
$M(AA)(BC)de$	5
$M(AB)(AB)cd$	5
$M(AB)(CD)ef$	10
$M(AB)_3$	2
$M(ABA)cde$	3
$M(ABC)_2$	5
$M(ABBA)cd$	3
$M(ABCBA)d$	3

LECTURE #25

8. RESOLUTION OF RACEMIC MIXTURE

A mixture of *d* and *l* isomers in equal proportion is known as a racemic mixture. A racemic mixture is optically inactive as expected. Sometimes, a racemic mixture exhibits different physical and chemical properties than any of the isomer. The separation of racemic mixture into its enantiomeric components (*d*-& *l*- forms) is called resolution. Since *d*- and *l*-form has same physical and chemical properties, they cannot be separated by ordinary methods like fractional crystallization and fractional distillation. Use of enzymes and chromatography has enabled the separation of some isomers.

Diastereoisomers are optically active isomers that are not enantiomers. The *cis* and *trans* isomers of a complex can sometimes be diastereoisomers. An important method in resolution of racemic mixture is using the formation of diastereomers.

If enantiomers of *dl*-mixture are acid, they give salt upon treatment with optically active base. In the same way basic enantiomers of a racemic mixture give salts upon reaction with optically active acid. The reactions with an optically active acid/base as required give two diastereomeric salts. These diastereomers can be separated by fractional crystallization on the basis of the difference in their solubility in water. The separated salts are treated with an optically active material to regenerate the optically active *d*-& *l*- forms.

For the resolution of *d*-cis $[\text{Co}(\text{en})_3]\text{Cl}_3$ and *l*-cis $[\text{Co}(\text{en})_3]\text{Cl}_3$ the racemic mixture is treated with an optically active *d*-tartaric acid. Two of Cl^- ions of the complexes are replaced by *d*-tartaric ion to give two diastereomers as shown below.

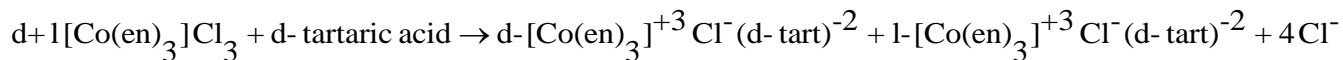

Upon crystallization, the *d*-cis- $[\text{Co}(\text{en})_3]^{2+}\text{Cl}^-(d\text{-tart})^{-2}$ separates in form of large crystals. Due to higher solubility, the crystals of *l*-isomers are obtained much later.

After separation, a treatment with concentrated hydrochloric acid gives the *d*- & *l*- chloride complexes as shown below.

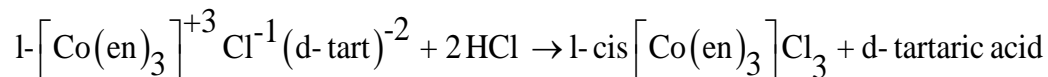
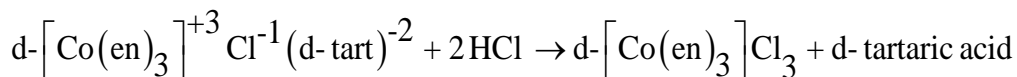

Numerous resolving agents like antimonyl tartarate ion ($\text{SbO}d\text{-tart}^-$) and *d*- α -bromo camphor- π -sulphonate anion for cationic complexes. Resolving agents used for anionic complexes are obtained from bases like brucine and strychnine. Methods that are more sophisticated are required for the resolution of neutral complexes. The neutral complexes can be resolved by preferential adsorption on quartz or sugars or extraction using asymmetric solvents. They can also be resolved using gas chromatography having capillary packed with solvents (Golay columns).

EXERCISES

MULTIPLE CHOICE QUESTIONS

N.B.: More than one option can be correct.

1. Which of the following complex ion shows geometrical isomerism?

- (a) $[\text{Cr}(\text{H}_2\text{O})_4\text{Cl}_2]^+$ (b) $[\text{Pt}(\text{NH}_3)_3\text{Cl}]$ (c) $[\text{Co}(\text{NH}_3)_6]^{3+}$ (d) $[\text{Co}(\text{CN})_5(\text{NC})]^{3-}$

2. The complexes of the type $[\text{Pd}(\text{C}_6\text{H}_5)_2(\text{SCN})_2]$ and $[\text{Pd}(\text{C}_6\text{H}_5)_2(\text{NCS})_2]$ are _____

- (a) linkage isomers (b) coordination isomers (c) Ionization isomers (d) geometrical isomers

3. The complexes $[\text{Co}(\text{SO}_4)(\text{NH}_3)_5]\text{Br}$ and $[\text{Co}(\text{SO}_4)(\text{NH}_3)_5]\text{Cl}$ represent _____

- (a) linkage isomerism (b) Ionization isomerism (c) coordination isomerism (d) no isomerism

4. Which type of isomerism exists between $[\text{Cr}(\text{H}_2\text{O})_6]\text{Cl}_3$ (violet) and $[\text{Cr}(\text{H}_2\text{O})_5\text{Cl}]\text{Cl}_2 \cdot \text{H}_2\text{O}$ (green)?

- (a) linkage isomerism (b) solvate isomerism (c) Ionization isomerism (d) coordination isomerism

5. Identify the optically active compounds from the following:

- (a) $[\text{Co}(\text{en})_3]^{3+}$ (b) trans $[\text{Co}(\text{en})_2\text{Cl}_2]^+$ (c) cis $[\text{Co}(\text{en})_2\text{Cl}_2]^+$ (d) $[\text{Cr}(\text{NH}_3)_5\text{Cl}]$

6. Identify the complexes show linkage isomerism from the following:

- (a) $[\text{Co}(\text{NH}_3)_5(\text{NO}_2)]^{2+}$ (b) $[\text{Co}(\text{H}_2\text{O})_5\text{CO}]^{3+}$ (c) $[\text{Cr}(\text{NH}_3)_5\text{SCN}]^{2+}$ (d) $[\text{Fe}(\text{en})_2\text{Cl}_2]^+$

SHORT / LONG ANSWER QUESTIONS

1. Which one of the following complexes is expected to be optically active?

- (a) cis- $[\text{CrCl}_2(\text{ox})_2]^{3-}$ (b) trans- $[\text{CrCl}_2(\text{ox})_2]^{3-}$

2. Which types of isomerism is exhibited by the following complexes?

- (i) $\text{K}[\text{Cr}(\text{H}_2\text{O})_2(\text{C}_2\text{O}_4)_2]$ (ii) $[\text{Co}(\text{en})_3]\text{Cl}_3$
 (iii) $[\text{Co}(\text{NH}_3)_5(\text{NO}_2)](\text{NO}_3)_2$ (iv) $[\text{Pt}(\text{NH}_3)(\text{H}_2\text{O})\text{Cl}_2]$

3. Justify that $[\text{Co}(\text{NH}_3)_5\text{Cl}]\text{SO}_4$ and $[\text{Co}(\text{NH}_3)_5\text{SO}_4]\text{Cl}$ are ionisation isomers.

4. How many geometrical isomers are possible in the following two complexes?

- (i) $[\text{Cr}(\text{C}_2\text{O}_4)_3]^{3-}$ (ii) $[\text{Co}(\text{NH}_3)_3\text{Cl}_3]$

5. Sketch the structures of optical isomers of following complexes:

- (i) $[\text{Cr}(\text{C}_2\text{O}_4)_3]^{3-}$ (ii) $[\text{PtCl}_2(\text{en})_2]^{+2}$ (iii) $[\text{Cr}(\text{NH}_3)_2\text{Cl}_2(\text{en})]^+$

6. Sketch all the isomers of following complexes:

- (i) $[\text{CoCl}_2(\text{en})_2]^+$ (ii) $[\text{Co}(\text{NH}_3)\text{Cl}(\text{en})_2]^{+2}$ (iii) $[\text{Co}(\text{NH}_3)_2\text{Cl}_2(\text{en})]^+$

7. List all the possible geometrical isomers of $[\text{Pt}(\text{NH}_3)(\text{Br})(\text{Cl})(\text{py})]$. How many of these will exhibit optical isomers?

8. A complex of the type $[M(AA)_2X_2]^{n+}$ is optically active; Giving a suitable example, comment on the structure of such complex?
9. A complex $Co(NH_3)_2(H_2O)_2Cl_2Br_2$ exists in two isomeric forms. Upon treatment with silver nitrate, one of the forms gives two moles of silver bromide while the other gives only one mole. Predict the structures of both the isomers.
10. A complex $Co(NH_3)_5(SO_4)Br$ exists in two isomeric forms. Upon treatment with silver nitrate, the first one gives silver bromide while the second one does not. However, the second isomer gives precipitates with an aqueous solution of $BaCl_2$. Predict the structures of both the isomers.
11. A, B and C are three isomers of a complex with empirical formula $H_{12}O_6Cl_3Cr$ having chloro and aquo ligands. The isomer A does not lose any weight with H_2SO_4 while B and C lose 6.75% and 13.5% of their weight. Identify A, B and C.
12. A complex cation, $[Pt(NH_3)(NH_2OH)(NO_2)(C_6H_5N)]^+$ is optically active. Predict the geometry of the complex.

MODULE 4:

THERMODYNAMICS AND KINETICS

Key words: Labile; inert; stability constants; complex formation; spectroscopy; Job's method;

Bjerrum method; polarography; electromotive force

MODULE 4: THERMODYNAMICS AND KINETICS

LECTURE #26

1. INTRODUCTION

The thermodynamic and kinetic studies are of paramount importance while synthesizing and reacting compounds. Using the knowledge of thermodynamic properties it is possible to know whether a particular transformation will occur or not. Once, thermodynamics okays the transformation, it is the kinetics that gives us information about the speed of transformation.

2. STABILITY AND LABILITY OF COMPLEXES

The term stability generally indicates the ability of a complex to exist for a period of time. Thus, stable complexes can be stored for a long time and under suitable conditions. The term stability is a relative term as different complexes may exhibit variable extent of stability with respect to different reagents. Moreover, the stability of the complexes is also evaluated with reference to the action of heat or light on a compound. Thus, stability is a general term and it may not be very useful unless used with suitable qualifications. While studying the reactions involving complex formation, both thermodynamic and kinetic stabilities require to be considered.

Thermodynamic stability of a complex is a measure of the extent of formation or transformation of a complex at the stage of equilibrium. Thus, a thermodynamically stable species does not readily undergo any reaction. Whereas, the complexes that are unstable in thermodynamic sense are expected to be reactive. However, one needs to keep in mind that the thermodynamic stability of a complex does not give any information regarding the speed of transformation.

Kinetic stability refers to the speed with which transformations leading to the attainment of equilibrium take place. The complexes which react quickly are called labile complexes while, the slow reacting complexes are named as inert complexes.

If the reactant species for a proposed reaction is thermodynamically stable, it will not undergo transformation without application of forcing conditions. If the reactant is thermodynamically unstable, it can be considered as a green signal for a reaction to proceed. Kinetics, at this stage must be referred to know the rate at which the proposed transformation will take place.

3. STEPS INVOLVED IN FORMATION OF A COMPLEX ML_n , STEPWISE AND OVERALL STABILITY CONSTANTS

The complex formation in solution proceeds by the stepwise addition of the ligands to the metal ion. Consider the formation of a complex ML_n occurring through a series of steps as shown below:

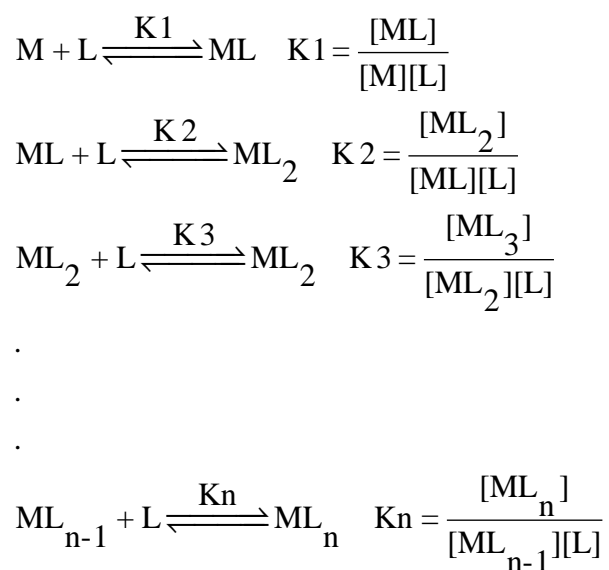

The equilibrium constants $K_1, K_2 \dots K_n$ are stepwise formation constants or stepwise stability constants which indicate the extent of formation of different species corresponding to a particular step. The values of stepwise stability constants for a complex formation reaction mostly decrease successively ($K_1 > K_2 > K_3 > \dots > K_n$). Steady decrease in the values of these constants is due to decrease in coordinated water ligands that are available to fresh ligands for replacement. Other than this, the decrease in ability of metal ions with progressive intake of ligands, steric hindrance and columbic factors also contributes to a steady decrease in successive stepwise stability constant values.

The stepwise stability constants fail to include the information regarding the previous steps. In order, to include the extent of formation of a species up to a particular step, the overall stability constants (β) are introduced. For instance, β_3 indicates the extent of formation up to step 3. Mathematically, it is the product of stepwise stability constants of steps 1 to 3.

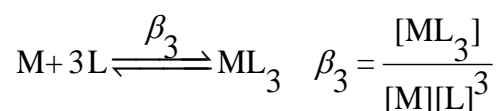

The equality of the product of stepwise stability constants; K_1, K_2, K_3 and overall stability constant can be shown as below:

$$K_1 \times K_2 \times K_3 = \frac{[ML]}{[M][L]} \times \frac{[ML_2]}{[ML][L]} \times \frac{[ML_3]}{[ML_2][L]} = \frac{[ML_3]}{[M][L]^3} = \beta_3$$

The above relation can be generalized as below:

$$\beta_n = K_1 \times K_2 \times K_3 \times \dots \times K_n$$

Since, the equilibrium constants are commonly expressed in logarithmic form, the above equation can also be shown as:

$$\log \beta_n = \sum_{n=1}^{n=n} \log K_n$$

To illustrate this, consider the formation of $[\text{Cu}(\text{NH}_3)_4]^{+2}$ ion



where K_1 , K_2 are the stepwise stability constants and overall stability constant.

$$\text{Also } \beta_4 = \frac{[\text{Cu}(\text{NH}_3)_4]^{+2}}{[\text{Cu}^{2+}][\text{NH}_3]^4}$$

The addition of the four amine groups to copper shows a pattern in which the successive stability constants decrease. In this case, the four constants are:

$$\log K_1 = 4.0, \log K_2 = 3.2, \log K_3 = 2.7, \log K_4 = 2.0$$

$$\text{Thus } \log \beta_4 = 11.9$$

The instability constant or the dissociation constant of coordination compounds is defined as the reciprocal of the formation constant.

4. EXPLANATION OF LABILITY AND INERTNESS OF OCTAHEDRAL COMPLEXES:

Valence bond theory (VBT)

According to VBT octahedral complexes may be either outer orbital complexes involving sp^3d^2 hybridization or inner-orbital complexes resulting from d^2sp^3 hybridization. In both the cases, e.g. orbitals are involved in hybridization.

As per VBT, the outer-orbital octahedral complexes are generally labile due to weakness of the bonds of sp^3d^2 type as compared with d^2sp^3 bonds. This prediction has been supported by complexes of Mn^{+2} ($3d^5$), Fe^{+3} ($3d^5$), Co^{2+} ($3d^7$), Ni ($3d^8$) and Cu^{2+} ($3d^9$).

In case of the inner-orbital octahedral complexes, the six d^2sp^3 hybrid orbitals are occupied by six electron pairs from ligands. The electrons of the central metal occupy the t_{2g} orbitals.

The inner orbital octahedral complexes having at least one d-orbital of t_{2g} set empty are known to be labile. Probably, this empty d-orbital is used to accept the electron pair from the incoming ligand during the formation of an activated complex with higher coordination number. In the inert inner-orbital octahedral complexes every d-orbital of t_{2g} set contain at least one electron.

Crystal field theory (CFT)

Substitution reactions in octahedral complexes follow either substitution nucleophilic unimolecular (SN^1) or substitution nucleophilic bimolecular mechanism. These pathways involve five coordinated (trigonal bipyramidal / square pyramidal) and seven coordinated (pentagonal bipyramidal) intermediates respectively. The formation of any of these intermediates involves

lowering of the symmetry. This in turn reduces the crystal field stabilization energy (CFSE). This loss in CFSE is the activation energy (E_a) required for the transformation.

The octahedral complexes formed by the ions for which there is a large loss in CFSE do not react rapidly and are inert. While, the complexes of the ions for which there is little or no loss in CFSE are labile.

LECTURE #27**5. FACTORS AFFECTING THE STABILITY AND LABILITY OF COMPLEXES****Factors affecting the kinetic stability of complexes**

The observed kinetic stability (lability or inertness) of a species is the result of multifaceted interplay between several factors. The effect of some such factors is summarized below.

<i>FACTOR</i>	<i>COMMENTS</i>
<i>Charge on the central metal ion</i>	Lability order for some isoelectronic species is $[AlF_6]^{3-} > [SiF_6]^{2-} > [PF_6]^- > [SF_6]^0$
<i>Radius of the central metal ion</i>	Order of lability for some [complexes](radius) : $[Mg(H_2O)_6]^{2+}(0.65\text{\AA}) < [Ca(H_2O)_6]^{2+}(0.99\text{\AA})$ $< [Sr(H_2O)_6]^{2+}(1.13\text{\AA})$.
<i>Coordination number</i>	Tetrahedral and square planar complexes exhibit higher lability towards isotopic ligand exchange compared to the octahedral moieties. This is because of the availability of a larger room for entry of the incoming ligands in case of 4-coordinated complexes.

Factors affecting the thermodynamic stability of complexes

A number of factors affect the stability of the complexes. Some of these factors depend on the nature of the central ion, while others depend on the nature of the ligand.

<i>FACTOR</i>	<i>COMMENTS</i>
<i>CENTRAL METAL ION</i>	
<i>Charge</i>	The value of stability constant for $[\text{Fe}^{+3}(\text{CN})_6]^{-3}$ is about four times greater than that of $[\text{Fe}^{+2}(\text{CN})_6]^{-4}$.
<i>Radius</i>	The hydroxide of magnesium (0.65Å) has four times greater value of stability constant as compared to the hydroxide of calcium (0.99Å).
<i>Crystal field stabilization energy (CFSE)</i>	<p>For a reaction</p> $\text{M} + 6\text{L} \xrightleftharpoons{\beta} \text{ML}_6 \quad \beta = \frac{[\text{ML}_6]}{[\text{M}][\text{L}]^6}$ <p>The overall stability constant follows the trend as shown below:</p> $d^0 < d^1 < d^2 < d^3 > d^4 \text{ and } d^5 < d^6 < d^7 < d^8 > d^9 > d^{10}$
<i>Class</i>	Class a metals: Na, Al, Ca, Ti, Fe and lanthanides.
<i>class a</i> → <i>Stable complexes with ligands</i>	Class b metals: Rh, Pd, Ag, Ir, Pt, Au and Hg.

having the coordinating atoms of the second period elements (e.g. N, O, F).

class b → Stable complexes with ligands

having the coordinating atoms from third period of elements (e.g. P, S, Cl)

LIGAND

Ratio of charge to size

Greater negative charge coupled with smaller size gives higher value of the ratio. Thus, the stability constant of a fluoro complex (10^6) of ferric ion is much higher than that of corresponding chloro complex (20).

Basicity

Stronger Lewis bases readily donate electron pairs and form complexes with greater stability. In line of this, ammonia forms more stable complexes than water which in turn forms more stable complexes than hydrofluoric acid.

Chelate effect

Complexes containing chelate ring are generally more stable than those without rings.

The value of stability constant for that of an ammonia complex with Ni (II) is 7.99 whereas with ethylenediamine (en) is 18.1.

The chelates are formed when a polydentate ligand uses more than one of its coordinating atoms to form a ring involving the metal ion. Here, the dissociation of one of the bonds with the metal ion does not detach the ligand molecule and hence the possibility of reestablishment of this bond is more as compared to an ordinary complex. Thus chelation provides additional stability to a complex molecule.

Number of chelate rings

ethylenediamine (en), diethylenetetramine (dien) are capable of forming one and two chelate rings respectively. The 1:2 complexes of these ligands with Fe^{+2} ion register the values of stability constants of 7.7 and 10.4 respectively.

The chelates containing 5 and 6 membered chelate rings show maximum stability.

Steric hindrance

The Ni(II) complex of oxine (8-hydroxy quinolone) has higher stability constant value of 21.8 as compared to an analogous complex with 2-methyl-8-hydroxy quinolone (17.8)

LECTURE #28**6. METHODS FOR DETECTION OF COMPLEX FORMATION**

A complexed metal ion exhibits strikingly different properties as compared to a free metal ion. The complex formation can be detected by studying such properties of metal ion. In addition to this, any property of a system, which is expected to vary with a change in the concentration of one of the species involved in the formation of the complex, can be used to sense the formation of a complex. Changes in properties like colour, melting point, stability towards oxidation or reduction, magnitude of ionic charge, solubility and crystalline form of the salts are also indicative of the formation of a complex. By careful consideration, it is possible to find one or more suitable methods for the detection of all types of complex formation in the solution.

1. Colour change

Many a times a colour change is accompanied with the complex formation. When ammonia is added to Cu^{2+} ion, a deep colour is obtained due to the formation of $[\text{Cu}(\text{NH}_3)_4]^{2+}$, a complex ion. This colour change gives an indication of the complex formation.

2. Solubility method

In certain cases, the formation of a complex increases the solubility of a sparingly soluble salt. When potassium cyanide is added to a solution of sparingly soluble silver cyanide, solubility of silver cyanide increases due to complex formation as shown below.

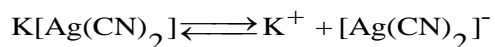
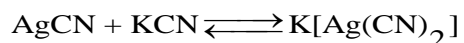

Similar change in solubility is observed when ammonia is added to a solution of sparingly soluble silver chloride. The formation of complex $[\text{Ag}(\text{NH}_3)_2]\text{Cl}$ which ionises as complex cation and chloride ion causes an apparent change in solubility of silver chloride.

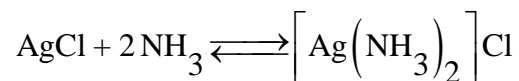

In the case of non-ionic complexes, the solubility of the complex in a water immiscible organic solvent and its distribution co-efficient can be used as a measure of the extent of complex formation.

3. Change in chemical properties

The fact that a complexed metal ion reacts differently than a free ion allows us to distinguish them and in turn can give evidences of complex formation. Addition of hydroxide ion to a solution of Fe^{+2} in the presence of EDTA does not result into precipitation of $\text{Fe}(\text{OH})_2$. This is because iron is in the form of complex $[\text{Fe}(\text{EDTA})]^{2-}$. Similarly, Cl^- does not cause precipitation of Ag^+ from aqueous ammonia solution as Ag^+ ions are present in the form of complex $[\text{Ag}(\text{NH}_3)_2]^+$.

However, the formation of complexes with low thermodynamic stability fails to qualify such test. This is due to an appreciable concentration of free metal ions in the solution. The complexes between ammonia and Ca^{2+} , Zn^{2+} or Al^{3+} give all the usual precipitation reactions of the free metal ion.

4. P^H method

Most of the complex formation reactions involve loss of one or more protons from the ligands. Thus, the complex formation may be considered to be the displacement of one or more, usually, weak acidic protons of the ligand by the metal ion. This displacement increases [H⁺] ion concentration in the medium resulting in to a drop in the P^H. Thus, the P^H effect can be used as an indication of the extent of complex formation.

5. Freezing point method

The properties that depend on the number of particles present in solution but are independent of their nature are called colligative properties. The depression of freezing point is a colligative property. Since the complex formation is a process, in which the number of particles decrease, a depression in freezing point is expected upon complexation.

6. Electrical Conductivity

Electrical conductance in solution is depends on the concentration of ions with high mobility. Complex formation is often accompanied by disappearance or formation of ions with different mobility. Thus, a change in the electrical conductance of the solution is usually observed which can be used as a basis for the detection of the formation of a complex.

The formation and disappearance of ions is demonstrated by the following example:



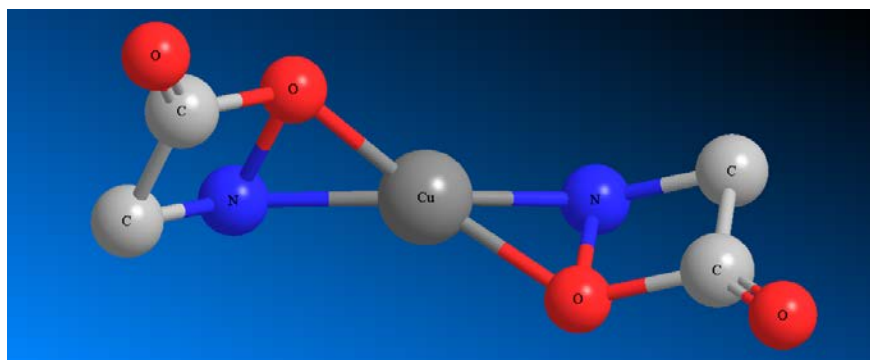

If the complex is sufficiently stable, this method can also be used to determine the charge on the complex by measuring the molar conductivity at infinite dilution. Sometimes, it is also possible to determine the structure of the complex provided the number of ions and their charges are known.

7. Ion Exchange Adsorption

This method is very useful in system where the charge on the complex is different from that of the metal ion. An anionic exchange resin cannot adsorb Zn⁺² cation from aqueous solution without the presence of a large excess of hydrochloric acid. In presence of hydrochloric acid, the zinc is in the form of negative ion [ZnCl₄]²⁻, which can be adsorbed on an anion exchange resin. Comparison of the concentrations of zinc in the resin and aqueous phase gives an insight into the extent of complex formation.

7. Dipole moment

A bond between two different atoms cannot be purely covalent. Depending on the electronegativity of the bonded atoms, the bonded electron pair shifts towards one of the atom. A

vector showing the magnitude and direction of the shifting of this electron pair is known as bond moment. In polyatomic molecules, each bond has individual bond moment. The dipole moment (μ) of a molecule is the vectorial addition of such bond moments. In the cases where all the individual bond moments are zero (homoatomic molecules), the resultant dipole moment is always zero. However, the converse is not true. Because of equal and opposite values of individual bond moments some molecules show a zero net dipole moment. As applied to coordination compounds a dipole measurement can be of value in distinguishing between isomers of a compound particularly between cis and trans isomers. A trans isomer exhibits low or zero dipole moment.

8. Magnetic Studies

Magneto chemistry is a very powerful tool in the hands of a synthetic coordination chemist. The magnetic behaviour reveals the number of unpaired electrons in a complex. This study also provides the information regarding the valence of the metal ion, the bond type and in turn, the geometry of the co-ordination compounds.

The magnetic moment (μ) of the transition metal ion in their compounds is directly related to the number of unpaired electrons (n) and can be equated as $\mu = \sqrt{n(n+2)}$

In some cases where inner d-orbitals are used for hybridisation, the complex formation may result in decrease of n . A decrease in the value of magnetic moment becomes an evidence of complexation in some cases. A free Ni^{+2} ($Z=28$) has eight electrons in five 3d orbitals. Here, six electrons are paired while two remain unpaired exhibiting a magnetic moment of 2.83 BM. In a

square planar complex of Ni (II), the dsp^2 hybridization requires one of the d-orbital to be vacated which results into the pairing to two unpaired electrons. Thus, a square planar complex of Ni (II) is diamagnetic ($\mu=0$).

9. Visible absorption spectral studies

The visible absorption spectroscopy also known as electronic spectroscopy is of paramount importance in coordination chemistry. The absorption of light in the visible region (330-800 nm) by a metal ion depends on the electronic transitions within the ion. It also depends on the type and strength of metal-ligand bonding.

Thus, the metal ions containing incompletely filled d-orbitals give different colours depending on the nature of the ligands attached with the metal ion. In most of the cases, the intensity of absorption is increased and the absorption shifts to lower wavelength when coordinated water molecules are replaced by ligands more basic than water.

10. Nuclear magnetic resonance (NMR) spectroscopy

Nuclear magnetic resonance spectroscopy, commonly known as NMR spectroscopy, is a technique which exploits the magnetic properties of certain atomic nuclei to determine physical and chemical properties of atoms and in turn the molecules in which they are contained. It is based nuclear magnetic resonance and can provide detailed information about the structure of molecules. It is applicable to a sample containing nuclei having resultant nuclear spin. When such nucleus is placed in a strong magnetic field, transitions occur between different spin energy states of the nucleus due to the absorption of frequencies.

In addition to proton n.m.r. and ^{13}C and ^{19}F n.m.r. are useful in studying metal ligand bonding in hydrido and fluoro complexes and of ligands having hydrogen, e.g., acetylacetonate (acac).

The chemical shift (designated as δ and having unit ppm) in the proton n.m.r. provides information about the complex formation.

Here also the method can be utilized even if there is no change in the number of unpaired electrons of the central atom or ion on complex formation.

11. E.S.R. Spectra

Electron spin resonance (ESR) spectroscopy also known as electron paramagnetic resonance (EPR) spectroscopy is analogous to nuclear magnetic resonance (NMR) spectroscopy. It is an electronic version of NMR spectroscopy. This technique is very useful in studying the complexes containing unpaired electrons. It gives information about the distribution of unpaired electrons in the molecule, which in turn helps in mapping the extent of delocalization of electrons over the ligand. When placed in a magnetic field, the molecules having unpaired electrons undergo transitions between different states. The absorption takes place in the microwave region and the energy of transition E is given by $E = h\nu = g\beta H$

Where, β is the magnetic moment expressed in Bohr Magnetons, H is the strength of the field and g is the ratio of magnetic moment to angular momentum known as gyromagnetic ratio.

These measurements provide the value of magnetic moment. The sub-bands in the absorption bands can explain the nature of metal-ligand bond in the complex.

The ESR measurements require very small quantity of sample. It is particularly useful for studying complex formation where there is no change in the number of electrons of the central metal or ion.

LECTURE #29

12. Electromigration Studies

The formation of a negatively charge complex ions can be detected using electrophoresis and electro dialysis. In both the above mentioned processes, the charged species are forced to move by application of external electric field. While the electrophoresis is applicable to dispersed particles having surface charge, electro dialysis is used to transport the ions in the solution. The reversed movement of complexed metal ion (coloured ion) towards the positive electrode instead of negative electrode serves as an indicative of complex formation.

Consider the formation Cobalt (III) aspartic acid complex. The complex shown below is an anionic complex. The movement of free Co (III) ion under the electric field will be reversed by the event of complex formation.

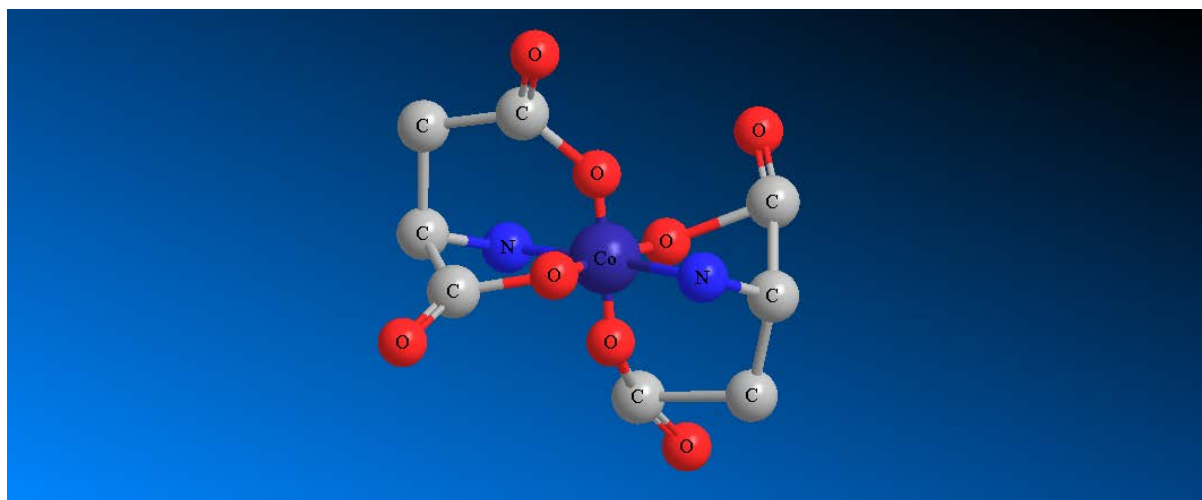

13. Change in Reduction Potential

The reduction potential of a species is its tendency to gain electrons and get reduced. It is measured in millivolts or volts. Larger positive values of reduction potential are indicative of greater tendency to get reduced.

We have seen earlier that the complex formation is accompanied by a decrease in ionic activity of the metal. Therefore, the reduction potential of the metal ion decreases upon complexation.

The standard reduction potential for a free Co^{+3} ion is 1.853 V while in complexed state $[\text{Co}(\text{NH}_3)_6]^{+3}$, it decreases to 0.1 V. Similarly, a free Fe^{+3} ion has a standard reduction potential of 0.771 V but $[\text{Fe}(\text{CN})_6]^{-3}$ has the value of 0.36 V.

In general, a decrease in reduction potential upon complex formation has been observed. This means that the higher oxidation states of the metal ion become more stable after complexation. This change in reduction potential although not popular in synthetic coordination chemistry can be made as a basis for the detection of complex formation.

14. Amperometry

Amperometry involves the measurements of currents at constant voltage applied at the dropping mercury electrode. The value of electrode potential is chosen in such a way that only the metal ion is reduced. This method is generally used for determination of metal ion present in aqueous solution. An aqueous solution of Zn^{+2} may be titrated with an EDTA solution at an applied electrode potential of -1.4 V.

The plot of volume of ligand Vs current in this case is shown in the figure below. From the graph, it is seen that there is decrease in current with an increase in ligand concentration, i.e., decrease in free metal ion concentration and finally attains a constant minimum value. This trend in the curve is an indicative of the complex formation.

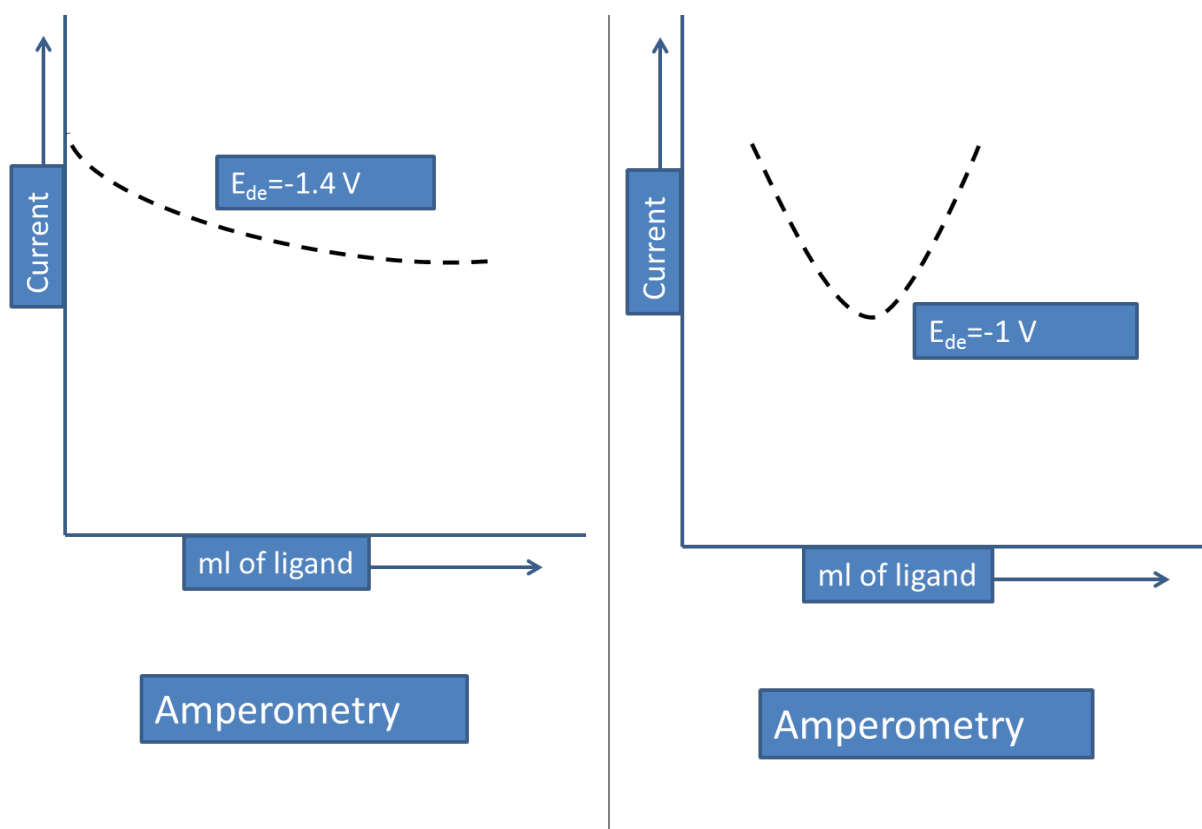

A V-shaped curve is obtained when an electrode potential is kept where both the metal ion and the ligand are reduced. An amperometric titration of Pb^{+2} with standard dichromate solution at an electrode potential of -1 V shows the graph with a V-shaped curve as shown in the figure.

15. E.M.F Method

Electromotive force abbreviated as EMF is the voltage generated by battery, which results into the flow of current. It is measured in volts. E.M.F. of any system depends upon the nature of the ion present in it. Due to the change in the type of ions, an appreciable change in the E.M.F. of the system occurs as a result of complex formation.

16. Polarographic method

The amperometric and polarographic methods rely on the same principle that the diffused current (i_d) is proportional to the concentration. Thus, when an electroactive material (metal ion) is removed from a solution using some reagent (ligand), a decrease in diffused current is observed. From the plot of current vs voltage known as polarogram, important information pertaining to the formation of a complex can be obtained. The characteristic half-wave potential of a simple metal ion is shifted when the metal ion undergoes complex formation. The informations from the polarography can also be useful in determining the stability constants and coordination number of the complex.

LECTURE #30**8. EXPERIMENTAL DETERMINATION OF STABILITY CONSTANT AND COMPOSITION OF A COMPLEX****Spectrophotometric method:**

This method is based on Beer's law, which says that

$$A = \epsilon \times l \times c$$

Where A is the optical density or absorbance, ϵ (epsilon) is the mole extinction coefficient, l is the length of the cell and c is the concentration.

Consider the formation of a complex given by the following reaction

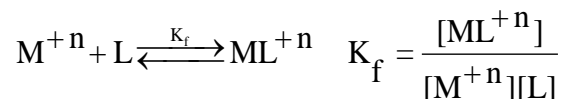

The complex $[ML^{+n}]$ exhibits a characteristic absorption pattern depending on its composition.

The wavelength at which the complex absorbs most is termed as λ_{max} . The value of the formation constant K_f can be obtained by measuring the absorbance (A) of the sample solution at the λ_{max} of the complex.

According to the standard procedure, a known quantity of metal ion and ligand are equilibrated.

Under equilibrium conditions, both metal and ligand can exist in the solution either in the free state or complexed form. Thus, the total metal concentration $[C_M]$ and total ligand concentration $[C_L]$ can be given as:

$$[C_M] = [M^{+n}] + [ML^{+n}] \text{ and } [C_L] = [L] + [ML^{+n}]$$

or

$$[M^{+n}] = [C_M] - [ML^{+n}] \text{ and } [L] = [C_L] - [ML^{+n}]$$

The term 'c' in the Beer's equation can be replaced by $[ML^{+n}]$ in this case.

Thus, Beer's equation can be shown as

$$[ML^{+n}] = \frac{A}{\epsilon \times l}$$

Hence,

$$[M^{+n}] = [C_M] - \frac{A}{\epsilon \times l} \text{ and } [L] = [C_L] - \frac{A}{\epsilon \times l}$$

The values from the above two equations enable the solution of the equation for the formation constant.

Job's method

Analogous to the spectrophotometric method, the Job's method also involves the measurement of absorbance of the complex at its λ_{\max} .

This method involves preparation of several sets with constant volume and variable concentrations of the complexes. Due to this, this method is also known as method of continuous variation. Using this method, it is possible to determine the metal-ligand ratio (composition) of a complex.

The standard procedure involves preparation of ten sets of solutions of complex. Different volumes of metal and ligand solutions are equilibrated in these sets in such a way that the total

volume of every set remains same. An illustration of such a set preparation is shown in the table below:

SET No.	1	2	3	4	5	6	7	8	9	10
M^{+n} (ml)	0	1	2	3	4	5	6	7	8	9
L (ml)	10	9	8	7	6	5	4	3	2	1
TOTAL (ml)	10	10	10	10	10	10	10	10	10	10

In each of the sets, the sum (C) of total concentration of metal ion (C_M) and total concentration of ligand (C_L) remains constant. i.e. $C = C_M + C_L$ remains constant.

The graph of the mole fraction of ligand ($mf_L = C_L/C$) against absorbance (A) measured at the characteristic λ_{max} will appear as shown below:

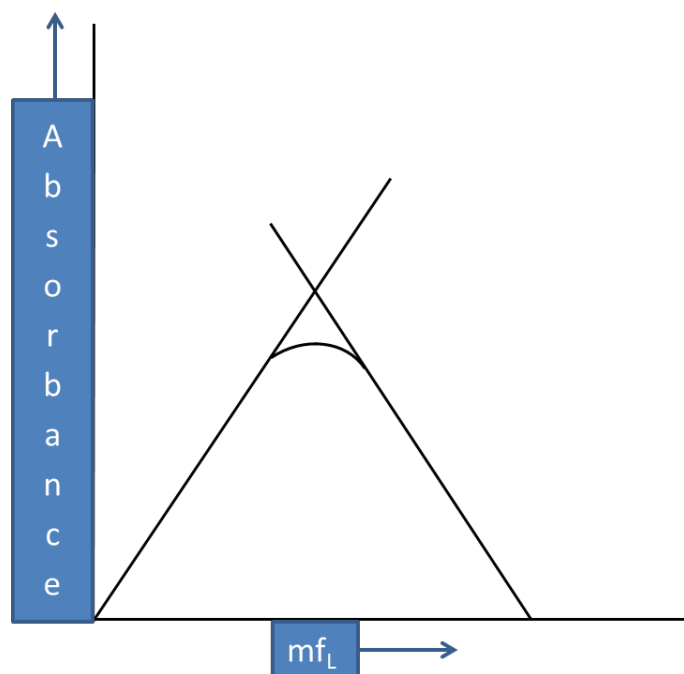

The mole fraction of ligand corresponding to the maximum absorbance can be identified by extrapolating the legs of the curve. From the Beer's equation, the absorbance is directly proportional to the concentration of the complex. Hence, this point corresponds to the composition with the maximum concentration of the complex.

For a complex ML_n , 'n' represents the number of ligands per metal ion and can be mathematically equated as C_L/C_M . Suppose, the complex is represented by a formula ML , the value of 'n' becomes unity and it is said that the metal ligand ratio in this case is 1:1. In such case, the concentration of the complex will be maximum in set number 6 which contains equal volume of metal and ligand solutions. The mole fraction of ligand corresponding to this set can give the value of 'n' using the following equation:

$$n = \frac{mf_L}{1 - mf_L}$$

For set number 6, $mf_L = C_L / C = 5 / 10 = 0.5$

Thus,

$$n = \frac{mf_L}{1 - mf_L} = \frac{0.5}{1 - 0.5} = 1$$

Even though, Job's method is a user's friendly method, it is necessary to make sure before using this method that the metal and ligand do not make complexes of more than one composition. Under certain circumstances, it becomes very difficult to create several sets with a constant volume. The application of Job's method is not possible in such cases.

Mole Ratio Method:

This method is similar yet simpler version of the Job's method. The difference between two methods is that in the molar ratio method, the total analytical concentration of metal / ligand is kept constant instead of the sum of ligand and metal concentration.

The absorbance is measured at a wavelength where the complex absorbs strongly but the ligands and metal ion do not. A plot between absorbance versus ligand to the metal concentrations (C_L/C_M) is prepared. Extrapolating the straight line portions until they cross, the value of $R=(C_L/C_M)$ gives the ratio of ligand to the metal ion in the complex.

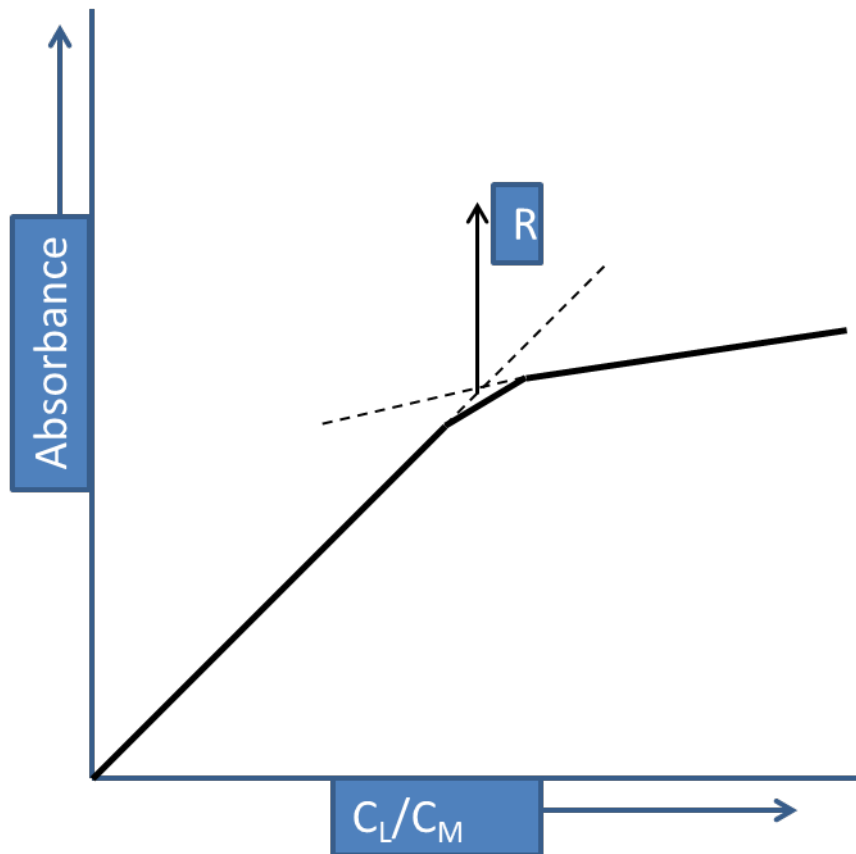

Mole Ratio Method

Hence, formula of the complex ML_n can be easily determined.

Matching Absorbance Method

This method is applicable for the determination of stability constants. The absorbance of two solutions having different metal to ligand ratios are measured at a wavelength where only the

complex absorbs strongly but the ligand and metal ion do not. The solution showing higher absorbance is diluted to an extent until the absorbance of the two solutions becomes the same.

Let the concentration of metal and ligand in solution (1) be C_{M1} and C_{L1} respectively and solution (2) C_{M2} and C_{L2} .

Now, for a 1:1 complex, we have

$$[M_1] = C_{M1} - [ML]_1$$

$$[L_1] = C_{L1} - [ML]_1$$

$$[M_2] = C_{M2} - [ML]_2$$

$$[L_2] = C_{L2} - [ML]_2$$

When the absorbance of the two solutions becomes equal then $[ML]_1 = [ML]_2 = C_s$ where C_s some unknown concentration.

The stability constant K can be calculated from the stability constant expression which contains C_s and K as unknown by eliminating C_s . Thus,

$$K = \frac{[ML_1]}{[M_1][L_1]} = \frac{[ML_2]}{[M_2][L_2]}$$

$$= \frac{C_s}{(C_{m1} - C_s)(C_{L1} - C_s)} = \frac{C_s}{(C_{m2} - C_s)(C_{L2} - C_s)}$$

And

$$C_S = \frac{(C_{m1}C_{L1}) - (C_{m2}C_{L2})}{(C_{m1} + C_{L1}) - (C_{m2} + C_{L2})}$$

Thus, the stability constant can be easily determined.

LECTURE #31**Bjerrum Method**

Bjerrum determined the stability constants of a large number of metal complexes forming in aqueous solutions. He described the stepwise formation of series of metal complexes of the type ML , ML_2 , ML_n by equations shown below:

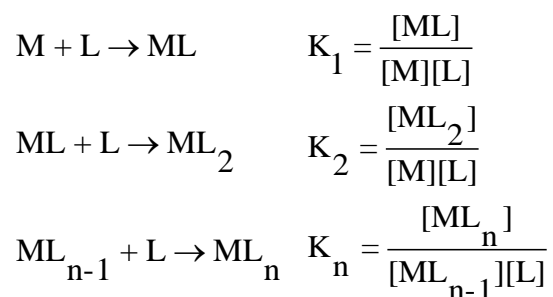

The equation for the formation constant corresponding to the first step can also be written as

$$[ML] = K_1[M][L]$$

Similarly for the second step,

$$[ML_2] = K_2[ML][L]$$

Substituting the value of $[ML]$ from the first equation into the second, we get,

$$[ML_2] = K_1 K_2 [L]^2 [M]$$

Thus,

$$[ML_n] = K_1 K_2 K_3 \dots K_n [L]^n [M]$$

A function \bar{n} is defined as the average number of ligand molecules bound per mole of metal and it is expressed:

$$\bar{n} = \frac{[ML] + 2[ML_2] + 3[ML_3] + \dots + n[ML_n]}{[M] + [ML] + [ML_2] + [ML_3] + \dots + [ML_n]}$$

Substituting the values of the complex concentrations from the previous equations, we get,

$$\bar{n} = \frac{K_1[M][L] + 2K_1K_2[M][L]^2 + \dots + nK_1K_2K_3 \dots K_n[M][L]^n}{[M] + K_1[M][L] + K_1K_2[M][L]^2 + \dots + K_1K_2K_3 \dots K_n[M][L]^n}$$

$$\therefore \bar{n} = \frac{K_1[L] + 2K_1K_2[L]^2 + \dots + nK_1K_2K_3 \dots K_n[L]^n}{1 + K_1[L] + K_1K_2[L]^2 + \dots + K_1K_2K_3 \dots K_n[L]^n}$$

The equation shown above is known as Bjerrum formation function. If the concentration of unbound ligand can be known experimentally, \bar{n} can be calculated from the equation shown below:

$$\bar{n} = \frac{L_t - [L]}{M_t}$$

Where L_t and M_t are the total concentration of ligand and metal respectively.

Solution of above equation for known values of n and corresponding (L) values gives the values of the formation constants, i.e., $K_1, K_2, K_3 \dots K_n$.

An illustration of the Bjerrum method for calculating the formation constants for a complex between Cu^{+2} and 5-sulphosalicylic acid (H_3L) is given below.

Procedure

The procedure involves titration of 100 ml of each solution CuSO_4 and 5-sulphosalicylic acid with standardised solution of sodium hydroxide. A graph of p^{H} against the volume of sodium hydroxide is plotted.

Note the point of inflexion of the curve which corresponds to the mixed solution. Calculation of the horizontal distance between the curves and are used to find values of \bar{n} . A plot the formation curve of \bar{n} against $-\log [\text{L}^{3-}]$, by obtaining the values of $[\text{L}^{3-}]$ found at various p^{H} from the equation shown below:

$$[\text{L}^{3-}] = \frac{[\text{HL}_3]_{\text{total}} - [\text{CuL}^-] - 2[\text{CuL}_2^{4-}]}{\frac{[\text{H}^+]^2}{[\text{K}_2\text{K}_3]} + \frac{[\text{H}^+]}{[\text{K}_3]} + 1}$$

Where K_2 and K_3 found from the formation curve of HL_3 which are 3.23×10^{-3} and 1.81×10^{-3} respectively.

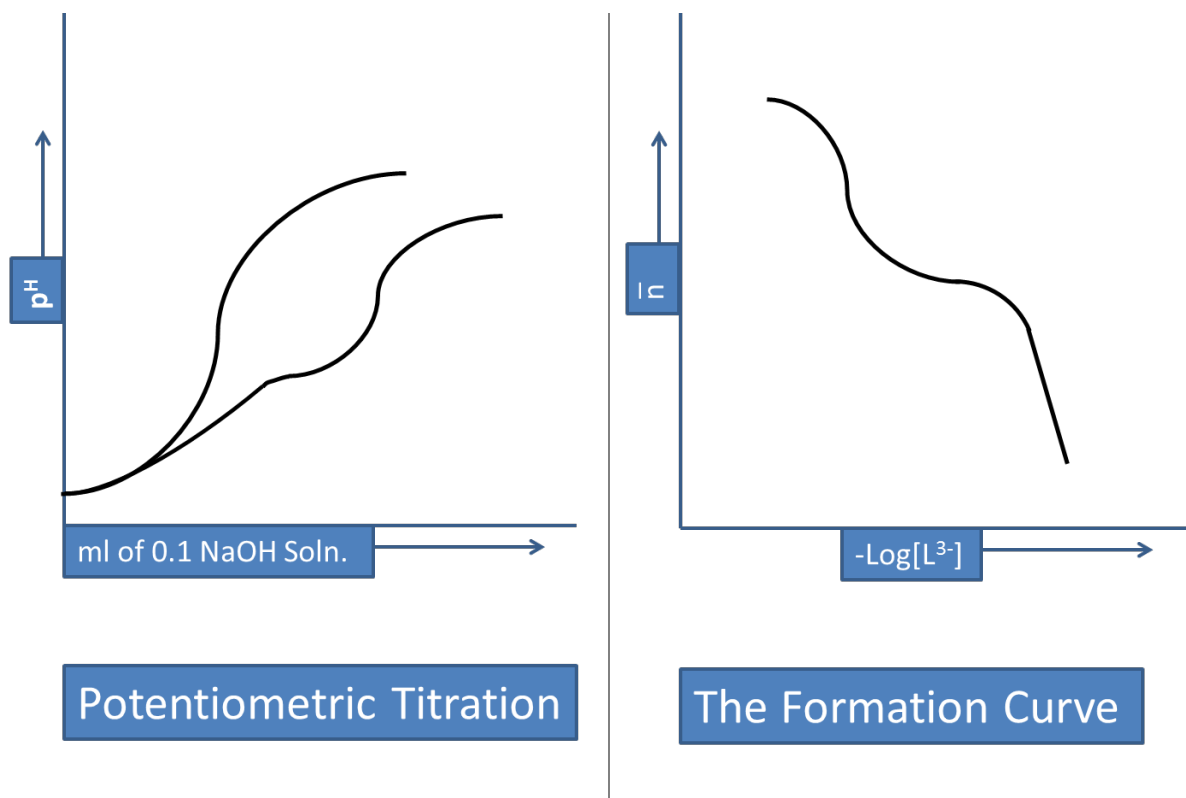

The values of K_1 and K_2 found from the formation curve at $\bar{n} = 0.5$ and $\bar{n} = 1.5$ are $K_1 = 2.2 \times 10^9$ and $K_2 = 6.3 \times 10^6$.

Polarographic Method

This method is based on an observation that the reduction potentials of metal ions are reduced as a result of complex formation. Consider the reaction:

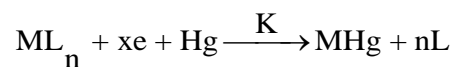

The above reaction occurring in two steps can be shown as:

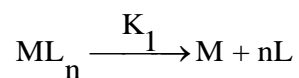

and

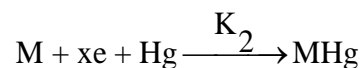

Here K is the overall formation constant while, K_1 and K_2 are the stepwise formation constants corresponding to the respective steps. Also, M is the metal, L the ligand, ML_n is the complex and the value of x indicates the number of electrons involved in the reduction.

A relation between the potential at the dropping mercury cathode (E), the half wave potential ($E_{0.5}$), the current (i) and the diffusion current (i_d) can be given as:

$$E = E_{0.5} - \frac{0.0591}{x} \log \frac{i}{i_d - i}$$

A plot of E against $(i / i_d - i)$ shows a straight line for a reversible potential. The slope (m) of this line for an equation of this type comes to $0.059/x$ where x is the number of electrons transferred in the reduction.

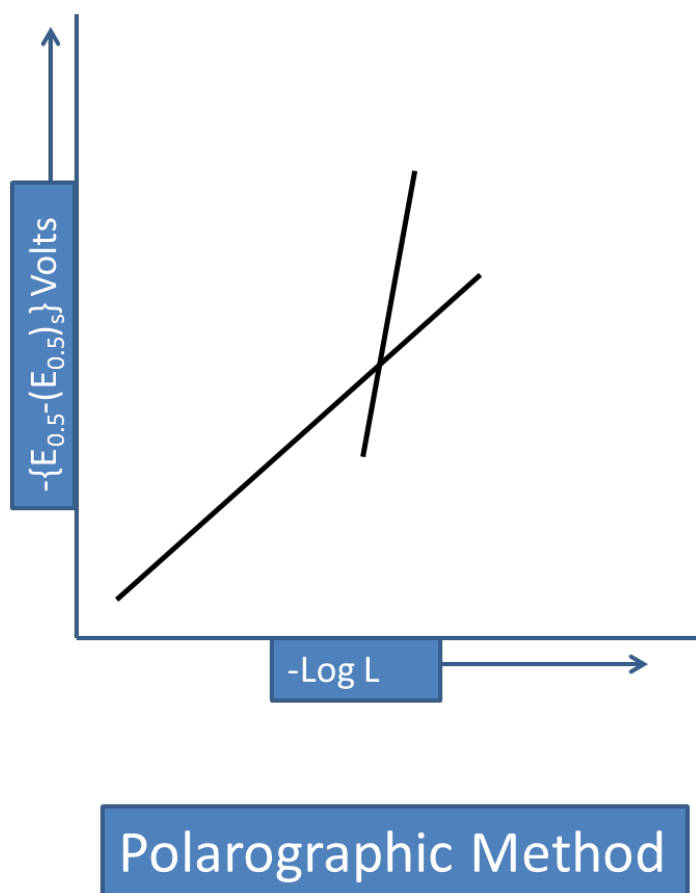

At 25° C

$$E_{0.5} = E^{\circ} - \frac{0.0591}{x} \log K - \frac{0.0591}{x} \log \frac{K_1}{K_2} - n \frac{0.0591}{x} \log [L]$$

Where, E° is the standard potential of the metal – amalgam electrode. The value of K_1/K_2 depends on the characteristics of the electrode and conditions during the experiment. n is the number of coordinated ligands and $[L]$ is the concentration of ligands.

The slope of the line obtained in the plot of $E_{0.5}$ vs $\log[L]$ comes to $-0.059 n / x$. The value of n can be calculated as the value of x is known.

$$E_{0.5} - E_{(0.5)s} = -\frac{0.0591}{x} \log K - n \frac{0.0591}{x} \log[L]$$

Where $E_{(0.5)s}$ is the half wave potential in the absence of ligands.

The plot of $E_{0.5} - E_{(0.5)s}$ against L yields a straight line, the intercept of which on the co-ordinate axis gives $(0.0591 / x) \log K$ and hence k can be determined. It is also clear that the slope of the line is $- n 0.0591/x$ so that the value of n can be calculated.

Solubility Method

This method is particularly useful in determining the stability constants of the complexes containing the metal ion capable of forming a sparingly soluble salt whose solubility product is known. Moreover, the complex formed should be fairly soluble. The stability constant of the complex can be determined by measuring the increase in solubility of the salt caused by the presence of the ligand. Consider the reaction of silver acetate with acetate ion. If a sodium or potassium acetate solution of known high concentration is equilibrated at constant temperature with an excess of silver acetate,

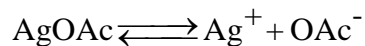

$$K_{\text{sp}} = [\text{Ag}^+][\text{OAc}^-]$$

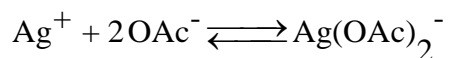

$$\beta_2 = \frac{[\text{Ag}(\text{OAc})_2^-]}{[\text{Ag}^+][\text{OAc}^-]^2}$$

After the equilibrium is achieved, the excess solid silver acetate is removed by filtration and the solution is analysed for total silver. Then, the total silver concentration in the solution is given as

$$C_{\text{Ag}^+} = [\text{Ag}^+] + [\text{Ag}(\text{OAc})_2^-]$$

From the expression for solubility product,

$$[\text{Ag}^+] = K_{\text{sp}} / C_{\text{NaOAc}}$$

Because of the large excess of sodium acetate.

Thus, the equation for the formation constant becomes

$$\beta_2 = (C_{\text{Ag}^+} - K_{\text{sp}} / C_{\text{NaOAc}}) / [(K_{\text{sp}} / C_{\text{NaOAc}} C_{\text{NaOAc}})^2]$$

Since all the remaining quantities are known, the overall stability constant β_2 can be easily calculated.

Electromotive Force Method

A metal in contact with a solution of ions gives rise to a potential (E) as shown by equation below:

$$E = E^0 - (RT/nF) \ln([M^{n+}] / [M]_{\text{solid}})$$

If two such cells with different metals are connected, the difference in voltage of the two cell potentials and can be measured. If both the cells are identical (same metal and the same concentration) the measured voltage difference will be equal to zero. Now, if a ligand solution is added to one of the cell, due to the complex formation a net voltage difference will be observed.

This observed difference in voltage can be given as:

$$E_{\text{obs}} = E_1 - E_2 = - (RT / nF) \ln [M^{2+}]_1 / [M]_{\text{solid}} - \ln([M^{2+}]_2 / [M]_{\text{solid}})$$

Where T is the absolute temperature, R is the gas constant; F is the Faraday (96500 coulombs); and n is the number of electrons transferred. Thus, the observed voltage is directly related to the free ion concentrations in the cells. In actual experiments, fixed volume of ligand is added successively to the metal ion solution in one cell, and the corresponding voltages measured. The stability constant can be evaluated from the knowledge of total concentration of the metal ion, ligand, and uncomplexed metal ion.

EXERCISES

MULTIPLE CHOICE QUESTIONS

- Which of the following complex reacts has a fast rate of reaction?
 - unstable
 - stable
 - labile
 - inert
- Which of the following complex does not easily react ?
 - octahedral
 - labile
 - stable
 - unstable
- What does 1/K values stand for?
 - Boltzman
 - variable
 - instability
 - stability

- constant constant constant
4. The complexes with large activation energy are found to be -----
(a) reactive (b) octahedral (c) inert (d) labile
5. Which of the following ligands will form more stable complexes?
(a) I^- (b) Cl^- (c) F^- (d) Br^-
6. The stability of a complex _____ with an increase in number of chelate rings .
(a) remains (b) vanishes (c) increases (d) decreases
constant
7. Which of the following methods is used to find the composition of a complex?
(a) Dumas (b) Spectrophotometric (c) Job's method (d) Bjerrum
method method method
8. The solubility of $AgCN$ _____ due to addition of KCN .
(a) increases (b) decreases (c) does not (d) becomes zero
change
9. An acidified aqueous solution of Zinc salt contains Zn as _____
(a) cation (b) atom (c) anion (d) All of these
10. What will be the value for the dipole moment for a molecule in which all the bond
moments are non zero?
(a) non zero (b) zero (c) negative (d) (a) or (b)
11. The square planar complexes of $Ni(II)$ are _____

(a) paramagnetic (b) diamagnetic (c) ferromagnetic (d) none of these

12. ESR technique is useful in studying complexes containing _____ electrons.

(a) free (b) paired (c) extra (d) unpaired

13. The electrophoresis technique is useful to detect the formation of _____ complexes

(a) polynuclear (b) cationic (c) neutral (d) anionic

14. Which type of shape of the curve is observed in amperometric plot when the electrode potential is kept at the value where both metal and ligand are reduce?

(a) 'V' shaped (b) 'C' shaped (c) 'U' shaped (d) 'L' shaped

15. Which of the following denotes Bjerrum formation function?

(a) K (b) Δ (c) β (d) \bar{n}

16. The reduction potential _____ as a consequence of complex formation.

(a) fluctuate (b) increase (c) remain constant (d) decrease

QUESTIONS WITH SHORT / LONG ANSWER

1. What is thermodynamic & kinetic stability?
2. Explain inert & labile inner orbital octahedral complexes according to VBT.
3. Explain inert & labile octahedral complexes according to CFT.
4. Mention factors affecting the lability of complexes in addition to the electronic configuration of the central metal ion forming the complexes with giving one example of each.
5. Explain the effect of geometry on the lability of complexes.

6. Mention all the factors affecting the stability of complexes.
7. Explain the effect of steric factors of ligand on the stability of complexes.
8. Distinguish between the S_N1 & S_N2 mechanisms of Nucleophilic substitution reactions in octahedral complexes.
9. What are the anation reactions? Explain.

MODULE 5:

REACTIONS IN OCTAHEDRAL COMPLEXES

Key words: Endothermic; exothermic; activation energy; acid hydrolysis; base hydrolysis; anation;

MODULE 5: REACTIONS IN OCTAHEDRAL COMPLEXES

LECTURE #32

1. POTENTIAL ENERGY CURVES SHOWING ENERGY CHANGES INVOLVED IN ENDOTHERMIC AND EXOTHERMIC REACTIONS

Let us consider a reaction

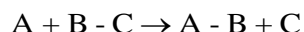

In the above reaction, the species A and B-C are reactants while A-B and C are the products. The potential energy changes involved during this transformation are presented graphically in two figures. From the figures, it can be seen that the reactants are converted into the products through a transition state, which involves the formation of an activated complex. This activated complex is a high-energy molecule with partial bonds. Thus it is not a true molecule and cannot be isolated due to extremely low stability. The energy required for the formation of this activated complex is the difference between the energy of the reactants and the energy of the activated complex. This energy is known as activation energy. From the figures it is also seen that apart from the reaction being endothermic or exothermic, the reactant molecules must acquire activation energy for successful transformation. For exothermic reaction, the energy of the product is lower than the energy of the reactants. This reaction energy (ΔH) is the energy released at the successful transformation. Thus, in case of exothermic reactions, if a few reactant molecules are initially activated externally, the energy released due to the transformation to

products becomes the driving force for the excitation of some more reactant molecules and the reaction continues without external supply of energy. While, in case of endothermic reactions, the energy of the products being higher than the reactants, the reactants must be continuously supplied external energy for the reaction to continue.

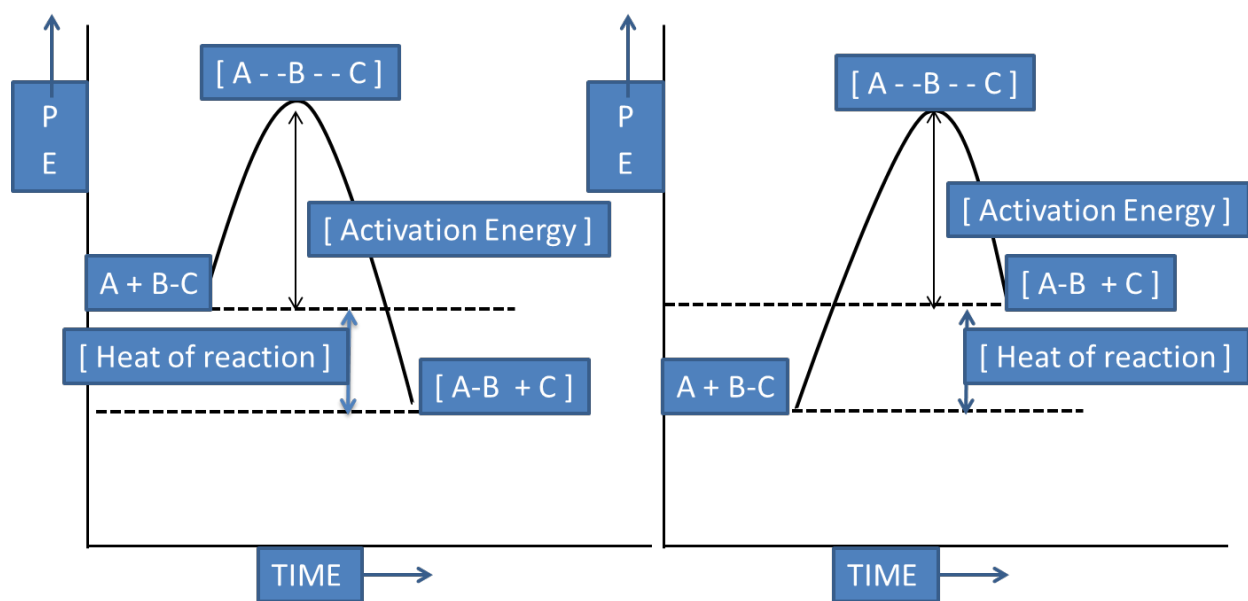

Fig: Energy changes involved in an exothermic and endothermic reaction.

A reactant molecule in which some bonds are broken and some new are formed is known as substrate. Thus, in the above reaction, B-C is the substrate. The above reaction proceeds when 'A' attacks on the substrate hence the species 'A' in the above reaction is called attacking reagent. If the attacking reagent is electron-loving (electrophile) like nitrosonium ion (NO^+) or bromonium ion (Br^+), it is deficient of electrons and hence will attempt an electrophilic substitution reaction on the substrate. More commonly in coordination chemistry, the attacking reagents are nucleus loving (nucleophiles) like chloro ligand (Cl^-), hydroxo ligand (OH^-) or

cyano ligand (CN⁻) which are electron rich and tend to replace some other ligand on the substrate molecule by nucleophilic substitution reaction.

2. MECHANISMS OF NUCLEOPHILIC SUBSTITUTION REACTIONS IN OCTAHEDRAL COMPLEXES

Nucleophilic substitution (SN) reactions in octahedral complexes are of paramount importance in coordination chemistry. These reactions follow any of the two popular mechanisms; SN¹ and SN².

SN¹ mechanism:

In the abbreviation, the letter 'S' indicates that the reaction is a substitution and the letter 'N' indicates the nucleophilic nature of the attacking reagent. The letter '1' is often misunderstood and considered to represent first order. However, '1' means that the molecularity (the number of different types of reactant molecules involved in a reaction) of the rate determining step (slowest step) in this mechanism is one (unimolecular). A nucleophilic substitution reaction involves removal of one ligand and its replacement by another ligand. According to this mechanism, the first step involves the removal of outgoing ligand. Therefore, this mechanism is also called dissociation mechanism.

Consider a nucleophilic substitution reaction in a complex with coordination number six (CN=6) octahedral (Oh) substrate MX₅Y occurring via SN¹ mechanism.

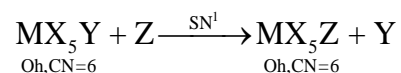

According to SN^1 mechanism, the first step involves loss of the leaving group Y. This breaking of M-Y bond results into formation of a five coordinated (trigonal bipyramidal / square pyramidal) intermediate. This step is slow and hence rate determining step.

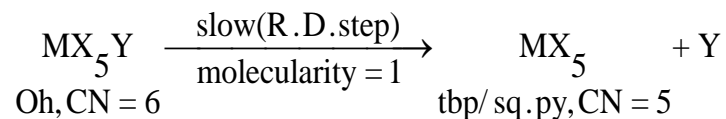

It should also be noted that the molecularity of this step is one.

At the onset of the second step, the vacancy created on the substrate due to loss of Y facilitates the entry of the incoming ligand Z. Thus in a rapid bimolecular step, the product MX_5Z is obtained.

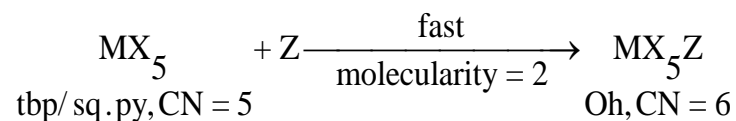

Since, the rate of slowest step determines the overall rate of the reaction and the rate of the slowest step (step 1) depends only on the concentration of the substrate MX_5Y .

The overall rate of reaction = $K [\text{MX}_5\text{Y}]$

A schematic diagram for an SN^1 mechanism is shown in the figure

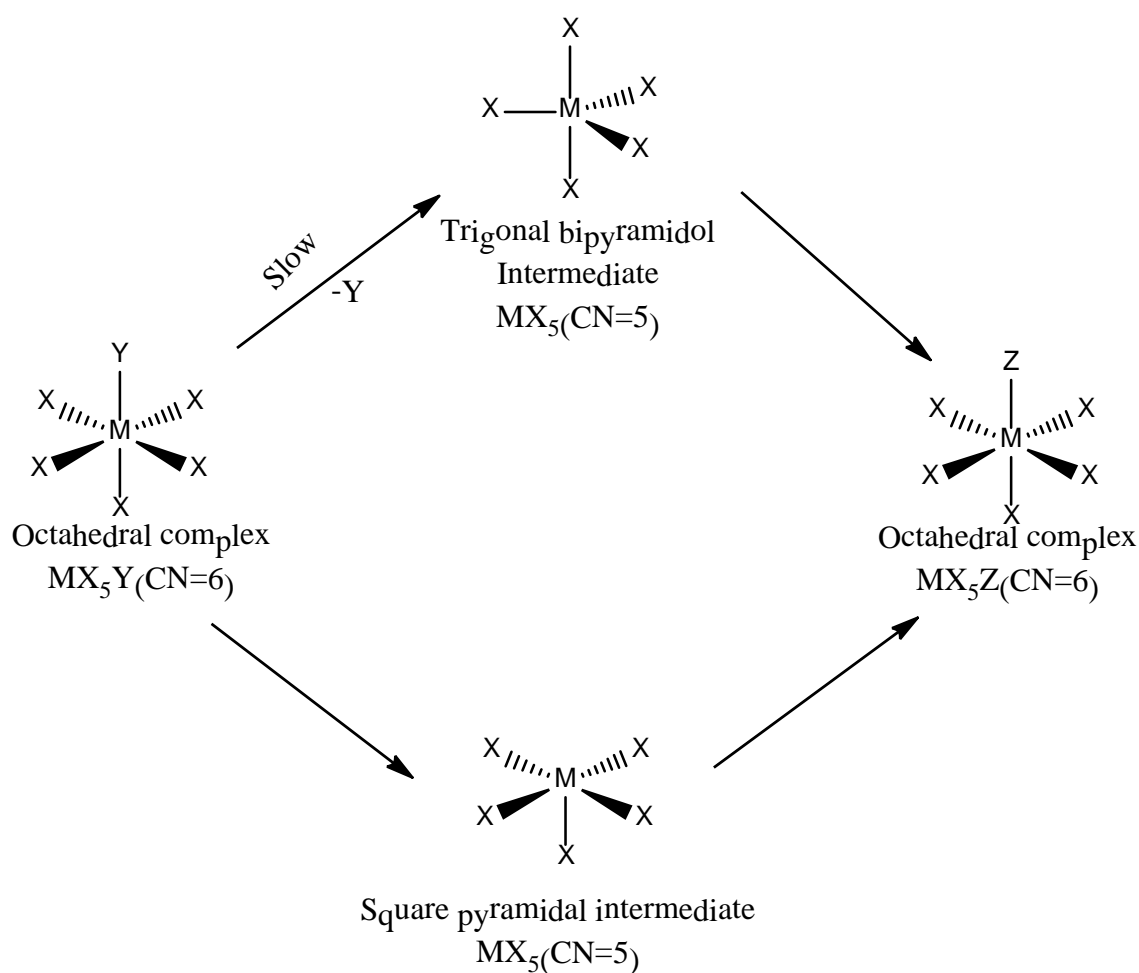
 **S_N2 mechanism:**

In the abbreviation, '2' means that the molecularity of the rate determining step (R.D. step) in this mechanism is two (bimolecular). According to this mechanism, the first step involves the entry of the attacking nucleophile Z . Therefore, this mechanism is also called association mechanism.

Consider a nucleophilic substitution reaction in a six coordinated (CN=6) octahedral (Oh) substrate MX_5Y occurring via S_N2 mechanism.

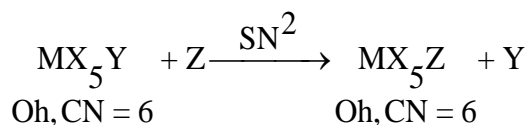

According to SN² mechanism, the first step involves addition of the incoming ligand Z. The making of this additional M-Z bond results into formation of a seven coordinated (pentagonal bipyramidal) intermediate. This step is energy expensive, sterically unfavored and hence slow (R.D.) step.

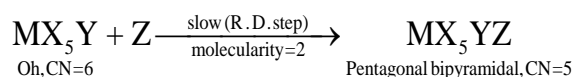

It should also be noted that the molecularity of this step is two.

At the onset of the second step, the crowding created on the substrate due to additional position occupied by Z facilitates the removal of the leaving ligand Y. Thus in a rapid unimolecular step, the product MX₅Z is obtained.

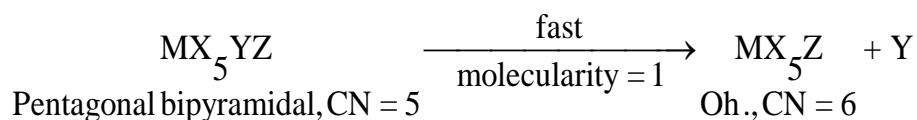

Since, the rate of slowest step determines the overall rate of the reaction and the rate of the slowest step (step 1) depend both on the concentrations of the substrate MX₅Y and the nucleophile Z,

The overall rate of reaction = K [MX₅Y] [Z]

Comparing the equations for rate of reactions for SN¹ and SN² mechanism, it is apparent that if the rate depends only on the concentration of the substrate, the mechanism followed for a

particular reaction is SN^1 . While, if the rate depends on the concentrations of the substrate and the attacking reagent, the probable mechanism is SN^2 .

A schematic diagram for an SN^2 mechanism is shown in the figure

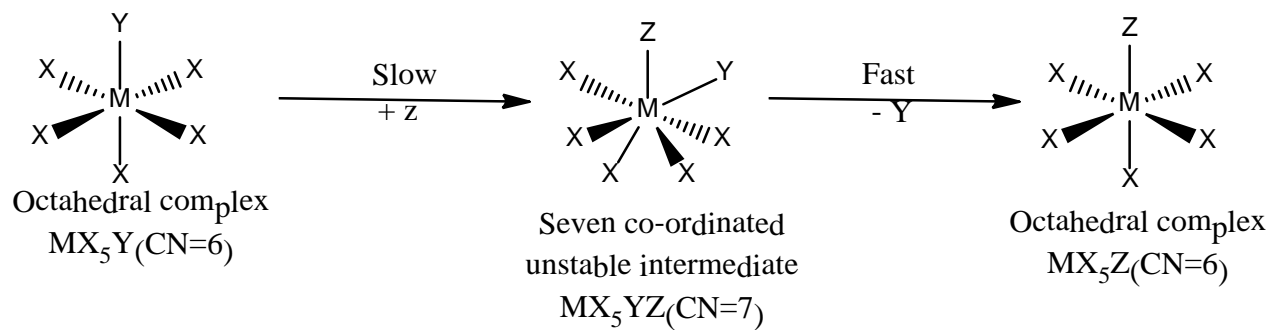

LECTURE #33

**3. MECHANISMS INVOLVED IN REACTIONS LIKE ACID HYDROLYSIS AND
BASE HYDROLYSIS OF SIX-COORDINATED CO (III) AMMINE
COMPLEXES**

Acid Hydrolysis and Base Hydrolysis

The water molecule can coordinate with metal ions in two different forms viz. OH_2 and OH^- . The substitution reaction in which the water molecule replaces any other ligand is called hydrolysis. The replacement of a ligand by a water molecule as OH^- yields a hydroxo complex and the reaction is termed as base hydrolysis. The base hydrolysis occurs at a pH above 10.

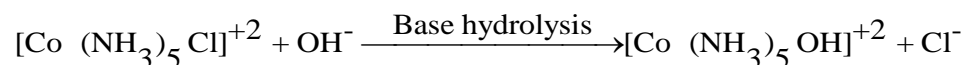

The replacement of a ligand by water molecule as H_2O yields an aquo complex and the reaction is termed as acid hydrolysis or aquation. The acid hydrolysis occurs at a pH below 3.

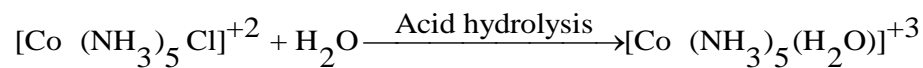
**Mechanism of Acid Hydrolysis of Six-Coordinated Co (III) Ammine Complexes**

In this reaction carried out in aqueous medium, water plays a double role viz. solvent and nucleophile. The species $[\text{Co}(\text{NH}_3)_5\text{Cl}]^{+2}$ is of particular interest because the ammonia ligand is not readily replaced by water molecules, which leave the possibility of replacement of only the chloro ligand. From the rate laws corresponding to the SN^1 and SN^2 mechanisms, we have seen

that, it is the effect of change in nucleophile concentration on the rate, which allows us to know the mechanism.

While carrying out this reaction in aqueous medium, it is impossible to change the concentration of water (nucleophile) in aqueous medium. The concentration of water in aqueous solutions is always constant and is 55.5M. The inability to change the nucleophile concentration does not permit us to distinguish the rate laws for SN^1 and SN^2 mechanism.

Thus, rate laws cannot provide any information regarding the mechanism of acid hydrolysis carried out in aqueous medium.

Mechanism of Base Hydrolysis of Six-Coordinated Co (III) Ammine Complexes

Consider a base hydrolysis given by the reaction

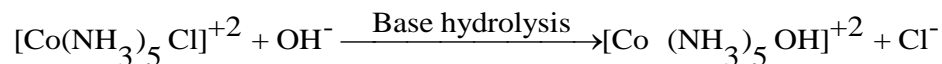

If the above reaction follows an SN^2 mechanism,

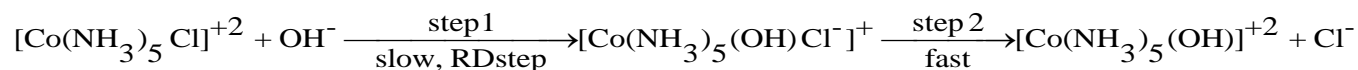

The rate of reaction = $K[\text{substrate}][\text{nucleophile}] = K[[Co(NH_3)_5Cl^{+2}][OH^-]$

The other probable mechanism for this reaction is SN^1CB mechanism. According to this mechanism, the ammine ligand of the substrate gives up a proton to form a conjugate base (CB) before it takes up the SN^1 pathway. i.e.



Thus,

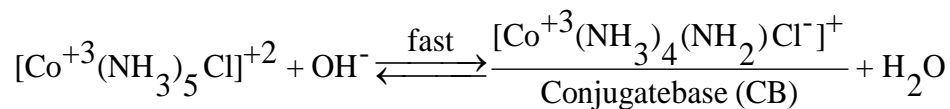

The equilibrium constant for the above reaction is given as

$$K = \frac{[\text{CB}][\text{H}_2\text{O}]}{[\text{Co}^{+3}(\text{NH}_3)_5\text{Cl}]^{+2}[\text{OH}^-]}$$

$$\therefore [\text{CB}] = \frac{K[\text{Co}^{+3}(\text{NH}_3)_5\text{Cl}]^{+2}[\text{OH}^-]}{[\text{H}_2\text{O}]}$$

The lability of the conjugate base is higher than that of the original substrate complex. Hence,

The CB can now undergo the SN^1 mechanism as follows:

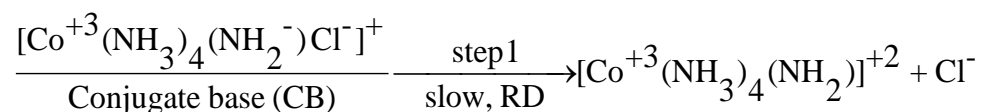

In the second and fast step, the 5-coordinated intermediate can now quickly react with the water molecules of the aqueous solution to give the product.

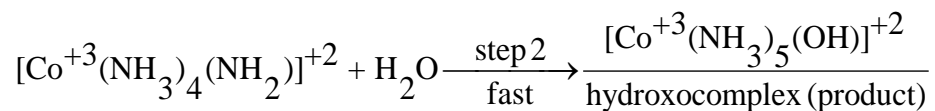

We know that the slowest step is the rate-determining step. Hence, the overall rate of base hydrolysis should be given by the rate of step 1 which is shown below

$$\text{Rate} = K_1[\text{CB}]$$

$$\text{but } [\text{CB}] = \frac{K[\text{Co}^{+3}(\text{NH}_3)_5\text{Cl}]^{+2}[\text{OH}^-]}{[\text{H}_2\text{O}]}$$

$$\therefore \text{Rate} = \frac{K_1 K[\text{Co}^{+3}(\text{NH}_3)_5\text{Cl}]^{+2}[\text{OH}^-]}{[\text{H}_2\text{O}]}$$

$$\text{Also, } \frac{K_1 K}{[\text{H}_2\text{O}]} = K_b (\text{Base dissociation const. for the conjugate base})$$

$$\text{Hence, Rate} = K_b[\text{Co}^{+3}(\text{NH}_3)_5\text{Cl}]^{+2}[\text{OH}^-]$$

It is important to note here that even though the SN^1CB mechanism is much like that of SN^1 but the rate of reaction depends on the concentrations of both substrate and nucleophile and is consistent with SN^2 mechanism.

In the Co (III) complexes with ligands containing replaceable proton i.e. NH_3 , en etc, the rate of base hydrolysis is often about a million times faster than acid hydrolysis. In order to establish the mechanism of base hydrolysis in such complexes, several experiments have been carried out. The base hydrolysis of Co (III) complexes with ligands without replaceable proton like $[\text{Co}(\text{CN})_5\text{Br}]^{3-}$ was found to be very low and independent of the concentration of nucleophile. Since, the non-leaving ligand do not contain replaceable proton, the SN^1CB mechanism is not possible. The failure of such complexes to undergo the base hydrolysis is an important indication supporting the operation on SN^1CB mechanism in base hydrolysis. Yet another evidence in favour of SN^1CB mechanism is seen while performing base hydrolysis in aprotic non-aqueous solvents like dimethyl sulphoxide.

It has been observed that the addition of hydrogen peroxide to a reaction mixture containing $[\text{Co}(\text{NH}_3)_5\text{Cl}]^{+2}$ ion and hydroxide ion reduces the rate of the base hydrolysis. Hydrogen peroxide dissociates as

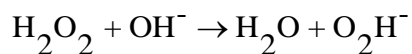

If the SN^2 mechanism was to operate, the species O_2H^- being a stronger nucleophile than hydroxide ion should give a peroxo complex $[\text{Co}(\text{NH}_3)_5(\text{O}_2\text{H})]^{+2}$ as the product. However, a peroxo complex is not formed under such conditions, which rules out the prevalence of the SN^2 mechanism.

For an SN^1CB mechanism, the rate of reaction is directly proportion to the concentration of the nucleophile (OH^-) and the addition of peroxide reduces the hydroxide concentration as shown in the above equation. Experimentally, the addition of hydrogen peroxide reduces the rate of base hydrolysis. Thus, all the above evidences lead to conclude that the base hydrolysis of cobalt (III) ammine complexes occur via SN^1CB mechanism.

LECTURE #34**4. ANATION REACTION**

The reaction in which an anionic ligand replaces a coordinated aquo ligand from a complex is known as anation reaction.

This is a reverse reaction of acid hydrolysis and may be represented as

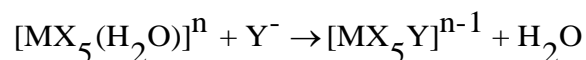

An example of anation reaction is shown below

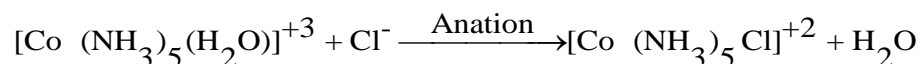

The rate of this reaction depends on the concentration of the complex as well as nucleophile.

However, the mechanism of this reaction is not yet established.

5. SUBSTITUTION REACTIONS WITHOUT M-L BOND CLEAVAGE

The decarboxylation of a carbonato complex to give an aquo complex is a classic example of this kind of reaction.

Consider the reaction

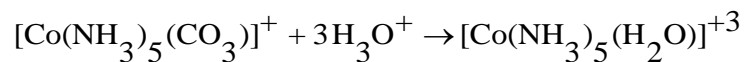

Primarily, this is an acid hydrolysis. However, the isotopic labelling of oxygen of nucleophile by (O^{18}) revealed that the oxygen atom from the nucleophile does not enter into the product. The most probable mechanism for this reaction is shown below:

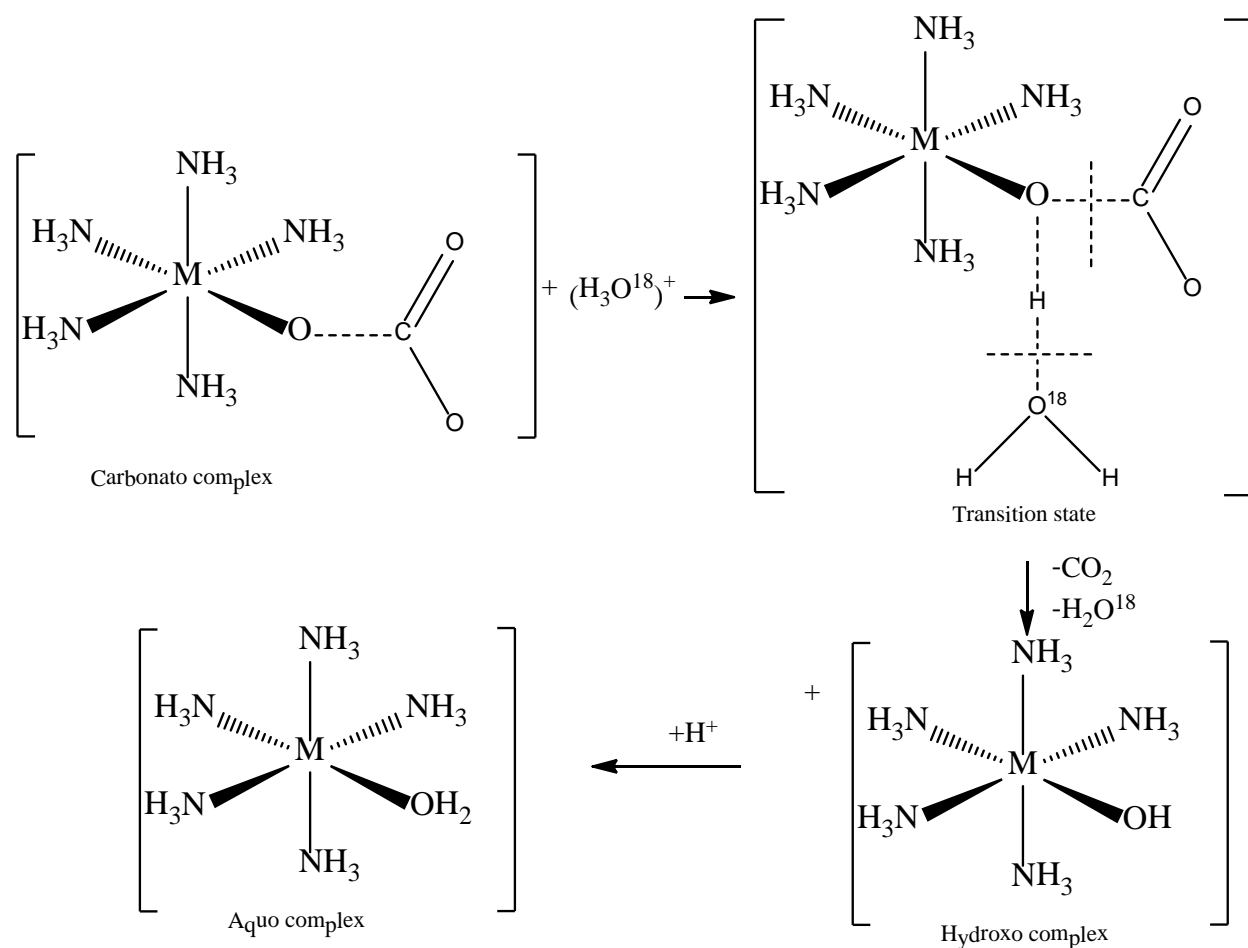

The above mechanism shows that upon the attack of proton on the oxygen atom bonded to the metal ion, carbon dioxide is eliminated accompanied by the release of a water molecule. This forms a hydroxo complex, which quickly takes up a proton from the medium to give the resultant aquo complex. The absence of isotopic oxygen (O^{18}) can be easily justified by the above mechanism.

The anation reaction of a cobalt (III) ammine aquo complex using (NO_2^-) as an anionic ligand also occurs without the cleavage of metal-ligand bond.

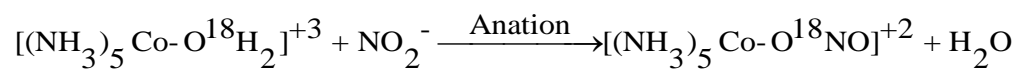

The retainment of the O^{18} isotope on the aquo ligand in the product complex confirms that the $\text{M}-(\text{O}^{18})$ bond is not broken.

LECTURE #35**6. ELECTRON TRANSFER REACTIONS**

The electron transfer reactions also known as oxidation – reduction reactions or redox reactions involve a transfer of electrons from one atom to the other atom.

The electron transfer reactions may be classified in to two types

1. Electron transfer reactions without chemical change.
2. Electron transfer reactions with chemical change.

Electron transfer reactions without chemical change:

Consider the complex ion pair, $[\text{Fe}(\text{CN})_6]^{3-}$ - $[\text{Fe}(\text{CN})_6]^{4-}$. A process involving the electron exchange between Fe^{+2} and Fe^{+3} with one of the ions labelled by an isotope can be shown as

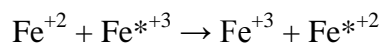

A similar reaction is observed between cerium ions in solution

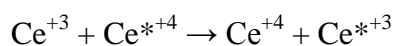

The above reaction does not involve any chemical change. These types of reactions are also known as self – exchange reactions.

An electron exchange reaction occurring between the cerium and iron ions (different ions) shown below is termed as electron transfer cross-reaction.

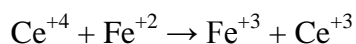
**Electron transfer reactions with chemical change**

Consider an oxidation-reduction reaction,

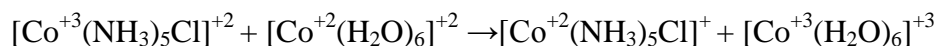

In the above reaction, the Co (III) ion bearing ammine and chloro ligands in the reactants binds six aquo molecules in the products. In the same way, Co (II) bearing six aquo ligands binds ammine and chloro ligands in the product. Thus, there is a net chemical change.

An electron transfer cross reaction of this type can be represented as

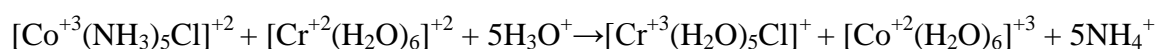

Mechanism of electron transfer reactions

There are two popular mechanisms for one-electron exchange reactions occurring in octahedral complexes

1. Inner sphere mechanism also known as bonded electron transfer or bridge mechanism.
2. Outer sphere mechanism also known as direct electron transfer mechanism.

Inner sphere mechanism also known as bonded electron transfer or bridge mechanism:

According to this mechanism, the electron transfer and the ligand transfer in the reaction occur at the same time. A close contact between the oxidant and the reductant of the reaction is required. The formation of a ligand bridge affords this intimate contact. The typical bridging ligands involved in such reactions are capable of conveying the electrons and contain more than one lone pair of electrons.

Henry Taube and co-workers discovered the operation of inner sphere mechanism in a redox reaction involving oxidation of $[\text{Cr}(\text{H}_2\text{O})_6]^{+2}$ using $[\text{Co}(\text{NH}_3)_5\text{Cl}]^{+3}$ in an acidic medium (1M HClO_4). The reaction is as shown below

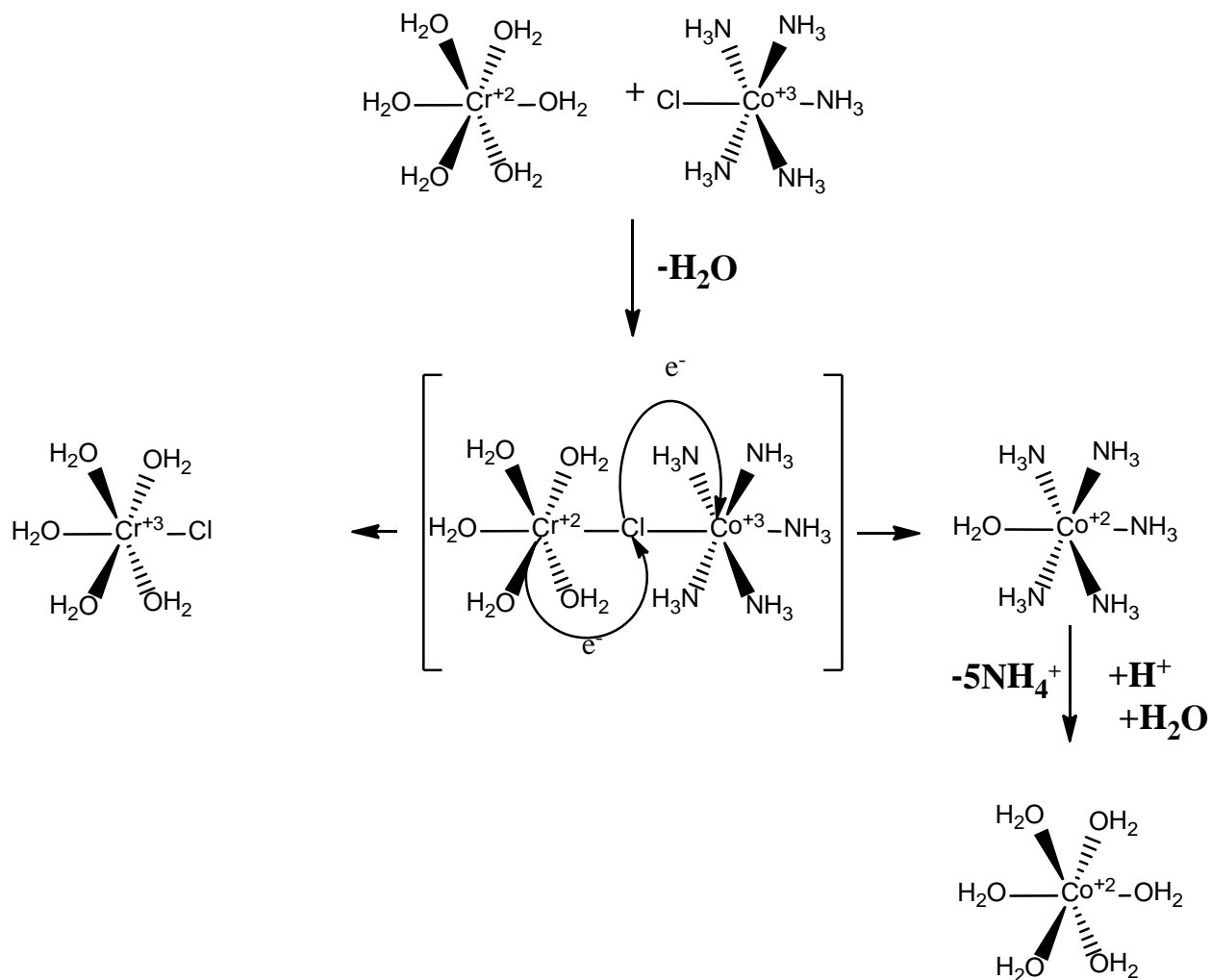
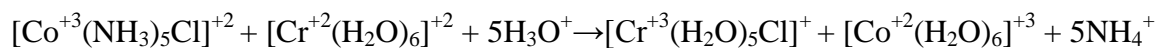

Figure: Mechanism of inner sphere electron transfer reaction.

The above reaction involves the following steps:

Step 1: The Cr (III) complex loses a water molecule and links with the Co (II) complex by a chloro bridge as shown in the figure.

The Co(II) complex is the only source of chlorine atom required for the formation of this bridged activated complex. This has been verified by isotopic labelling. When this reaction is carried out in a medium containing free Cl⁻ ions and using the Co (II) complex containing isotopically labelled chlorine (³⁶Cl), only labelled chlorine is found in the product.



Thus, according to the inner sphere mechanism operating in the above reaction, the chloro bridge formed between the two complexes provides a pathway for the transfer of electron between the metals.

In the above example, the formation of the chloride bridge was not observed experimentally but was inferred from the analysis of the product analysis. Creutz-Taube complex shown in the figure below is a model for the bridged intermediate. This ion was named after Carol Creutz, who prepared it while working with Taube. Pyrazine is the bridging ligand here. In the Creutz-Taube Ion, the average oxidation state of Ru is +2.5. Spectroscopic studies have shown that the two Ruthenium centres are equivalent, which indicates the ease with which the electron hole communicates between the two metals. Many more complex mixed valence species are known both as molecules and polymeric materials

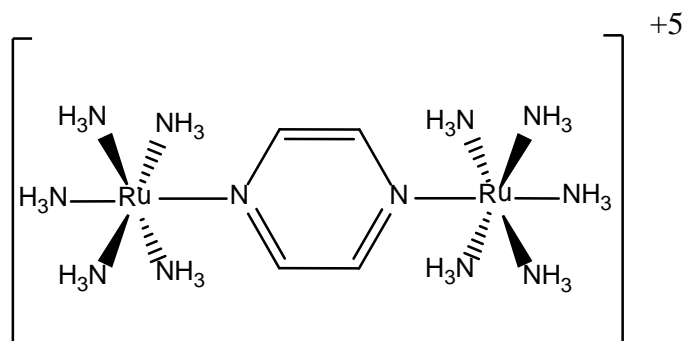

Figure: Creutz-Taube complex ion.

Step 2: The electron transfer from Cr (II) to Co (III) in the bridged activated complex occurs through the chloro bridge. This results in to oxidation of Cr (II) to Cr (III) and reduction of Co (III) to Co (II).

Step 3: The Cr (III) attracts Cl^- ion more strongly as compared to Co (II). Due to this, the chloro ligand becomes a part of the chromium complex in the final product.

Thus, we see that in this reaction Co (III) loses a chloro ligand but gains an electron while Cr (II) gains a chloro ligand but loses electron.

Experimentally, this reaction is found to be of the first order with respect to both the reactants.

Hence,

$$\text{rate} = K [[\text{Co}^{+3}(\text{NH}_3)_5 \text{Cl}]^{+2}] [[\text{Cr}^{+2}(\text{H}_2\text{O})_6]^{+2}]$$

It is also seen that the rate of this reaction depends much on the ability of the bridging ligand to provide the path for the electron transfer.

It has been observed that the rates of electron transfer reactions with the complexes of general formula $[\text{Co}^{+3}(\text{NH}_3)_5 \text{X}]^{+2}$ varies as $\text{SO}_4^{-2} < \text{Cl}^- < \text{Br}^-$

A variety of such reactions differing with respect to the number of electrons transferred and number of bridges formed has been studied.

A reaction,

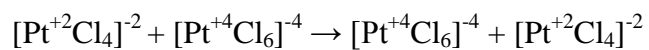

represents an example of two electron transfer reaction occurring through a single bridge.

LECTURE #36

Outer sphere mechanism also known as direct electron transfer mechanism:

A redox reaction following outer sphere mechanism involves the tunnelling of electron between the two reactants without creating a significant change in their environments.

In order to understand the outer sphere mechanism consider a self – exchange reaction

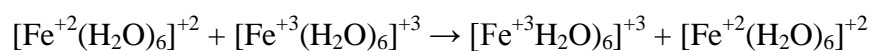

From the isotopic labelling and nmr studies, it has been observed that the reaction has a rate constant consistent with the second order reaction and occurs rapidly at 25°C. The reaction being without chemical change, there is no change in heat or reactants.

The mechanism involves the intimacy of the two complexes resulting into the formation of a weak outer sphere complex as shown in figure below. A sufficient overlapping between the acceptor and the donor orbitals of the reactants facilitates the electron transfer.

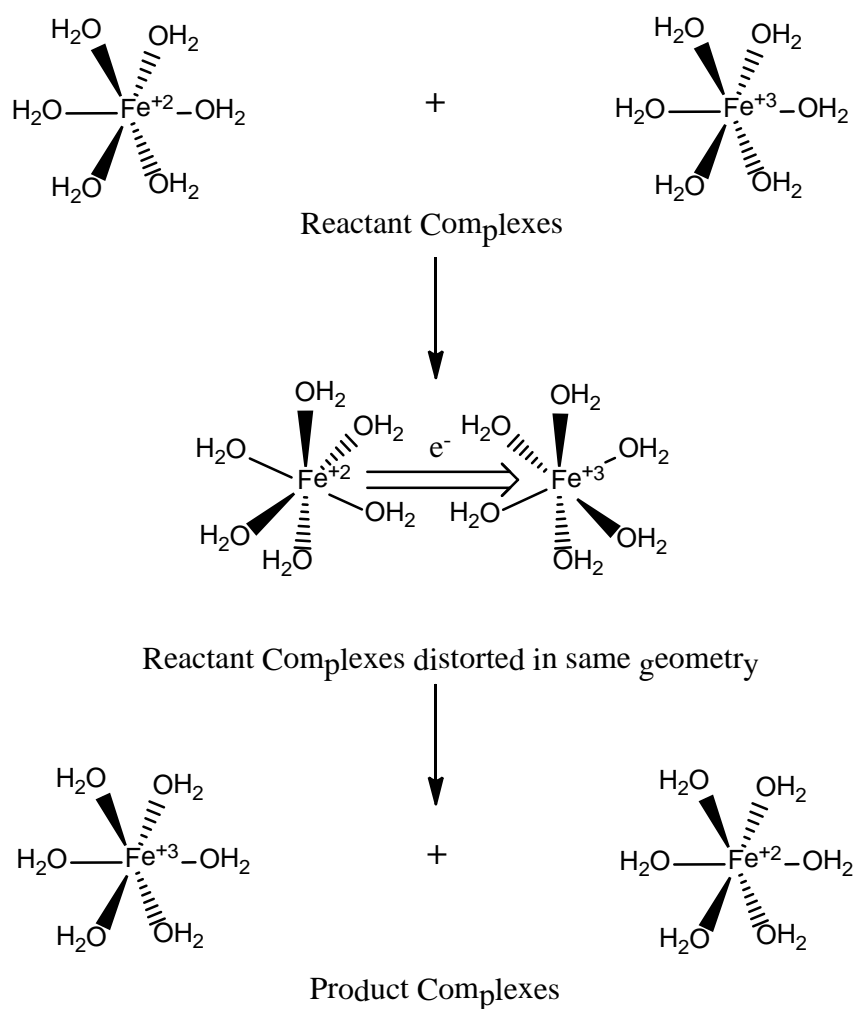

Figure: Mechanism of outer sphere reaction in $\text{Fe}^{2+}/\text{Fe}^{3+}$ couple.

According to the Frank – Condon principle the electronic transitions being very fast occur without a significant change in atomic environment.

A plot of nuclear coordinates of the reactants and potential energy shown below indicates that an instantaneous electron transfer is possible when the reactants are at their energy minimum state.

The point of intersection of the curve shows the time when the reactants are in same nuclear

configuration and a quick electron transfer occurs. The energy required to reach this position is known as Gibb's activation energy (ΔG^a). Thus, larger the difference in nuclear configuration of the reactants more will be the ΔG^a and slower will be the transfer of electrons.

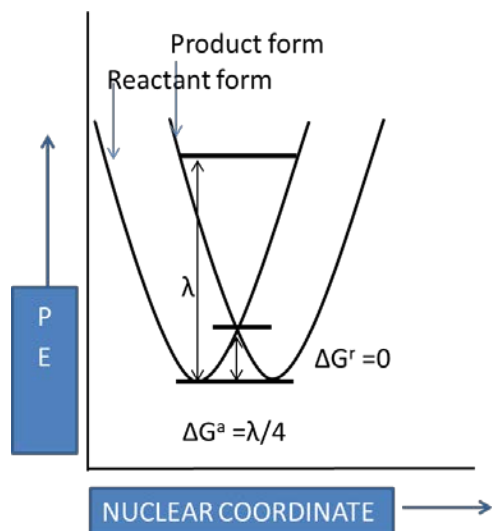

Figure: Potential energy curve for self – exchange reaction.

Rudolph Marcus developed the main theory describing the rates of outer-sphere electron transfer in the 1950s. According to this theory, the rate of electron transfer depends on the difference in the redox potentials of the electron-exchanging sites. For most reactions, the rates increase with increased driving force. Another aspect is that the rate depends inversely on the reorganizational energy (λ) which describes the changes in bond lengths and angles that are required for the oxidant and reductant to switch their oxidation states.

According to the Marcus equation

$$k_{\text{ET}} = \nu_{\text{N}} K_{\text{e}} e^{-\Delta G^{\text{a}}/RT}$$

Where k_{ET} is the rate of electron – transfer and ΔG^{a} is given by the following equation

$$\Delta G^{\text{a}} = 1/4\lambda \left(1 + \frac{\Delta G^{\text{r}}}{\lambda} \right)^2$$

In the above two equations,

k_{ET} is the rate constant for the electron transfer,

ν_{N} is the nuclear frequency (the frequency at which the reactants encounter in the solution to achieve a transition state),

K_{e} is the electronic factor (ranges from 0 to 1 and indicates the probability of electron transfer after reaching the transition state),

ΔG^{a} is the Gibb's activation energy,

R is the gas constant,

T is the temperature of reaction in Kelvin scale,

λ is reorganization energy and

ΔG^{r} is the Gibb's reaction energy (obtained from the standard potentials of the redox partners, large negative values indicate that the reactions are thermodynamically favourable).

The figures a, b and c shown below represents the variation of ΔG^{a} with ΔG^{r} in self exchange reaction, activation less reaction and a reaction in which ΔG^{a} increases as ΔG^{r} becomes more negative than $\Delta G^{\text{r}} = -\lambda$

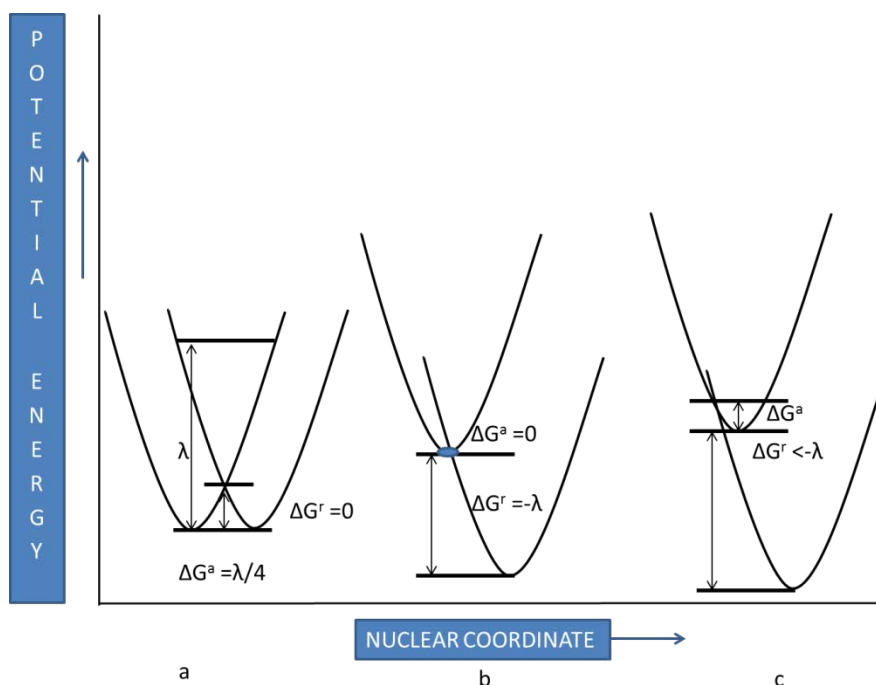

Figure: Potential energy curve for different reactions following outer sphere mechanism

For a self – exchange reaction (figure a), the value of ΔG^r is zero. From the Marcus equation, in such cases, the value of $\Delta G^a = \frac{1}{4} \lambda$. Thus, the reorganization energy, λ governs the rate constants of such reactions.

For the redox reactions occurring between different species, ΔG^r remains non – zero (figure b & c).

In the Marcus equation, ΔG^a becomes zero when ΔG^r equals $-\lambda$. Under such conditions, the reaction becomes activation less due to mutual cancellation of activation energy and reorganization energy.

With larger negative values of ΔG^r as shown in figure c, the activation energy (ΔG^a) increases according to the Marcus equation and the rate of the redox reaction decreases. This slowing of the reaction is known as inverted behaviour.

LECTURE #37**7. ISOMERIZATION REACTIONS**

In the presence of a chelating ligand, an isomerization can take place due to the breaking of a metal – ligand bond. An isomerization reaction occurring in tris(3-acetylpentane-2,4-dione)cobalt (III) complex is shown in the figure below. In order to track the mechanism of the reaction, a set of deuteriated hydrogen is placed at the outer methyl group of the complex as shown in the figure. The exchange of the outer CD₃ group with the inner CH₃ group affords the isomerization without loss of any ligand. It has been observed that the racemization of [Ni(en)₃]⁺² takes place by such intramolecular twist.

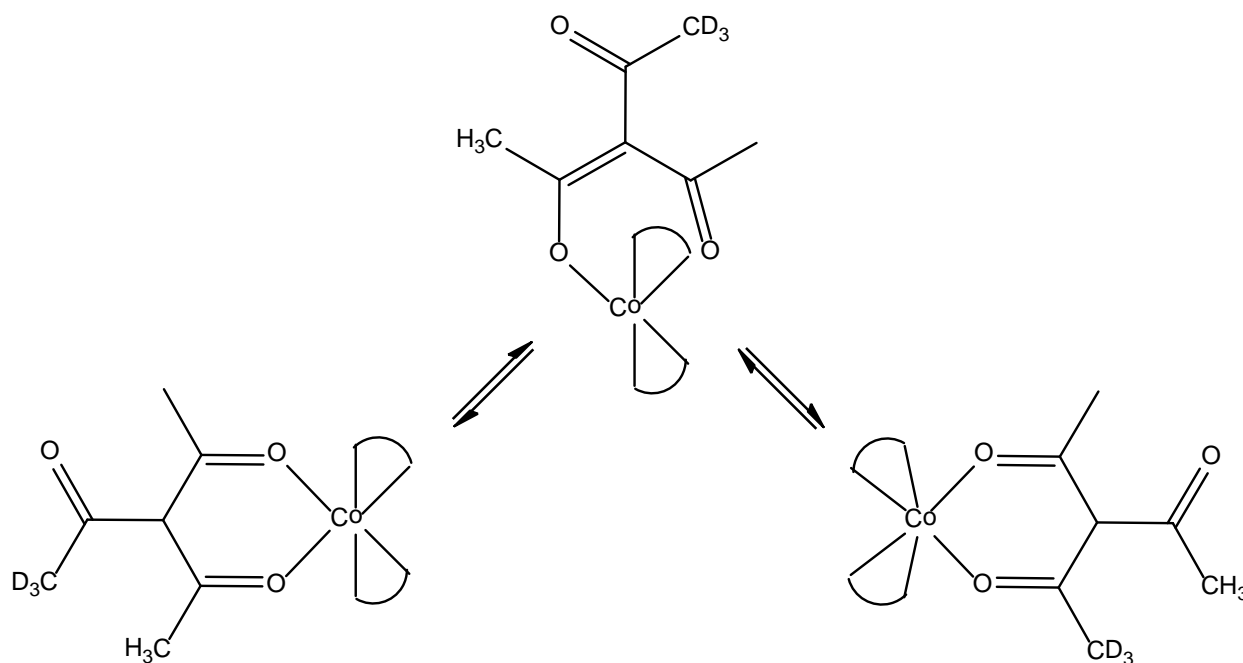

Figure: Isomerization reaction in tris(3-acetylpentane-2,4-dione)cobalt(III) complex

The two popular mechanisms for the intramolecular rearrangement in octahedral complexes known as Bailar twist and Ray-Dutt twist occurring through prismatic intermediates are shown in the figure below:

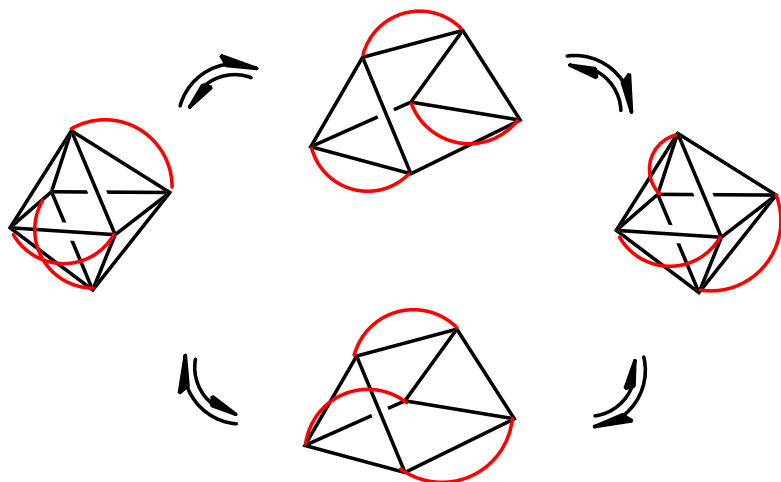

Figure: Ray-Dutt twist (top) and Bailar twist (bottom) in isomerization of octahedral complex.

EXERCISES

MULTIPLE CHOICE QUESTIONS

1. A reactant in which some of the bonds are broken and some new bonds are formed is called _____.
 (a) electrophile (b) nucleophile (c) substrate (d) attacking reagent

2. The concentration of water in aqueous solution is nearly _____ M.
 (a) 18 (b) 0.1 (c) 55.5 (d) 1
3. The geometry of the intermediate during SN^1 mechanism operating on an octahedral complex is_____.
 (a) trigonal (b) square pyramidal (c) pentagonal (d) (a) or (b)
 bipyramidal bipyramidal
4. The geometry of the intermediate during SN^2 mechanism operating on an octahedral complex is_____.
 (a) trigonal (a) square pyramidal (a) pentagonal (a) (a) or (b)
 bipyramidal bipyramidal
5. An anation reaction is a reverse reaction of _____ reaction.
 (a) hydrolysis (b) carboxylation (c) ammonolysis (d) addition
6. The base hydrolysis of $[\text{Co}(\text{CN})_5\text{Br}]^{-3}$ is_____
 (a) very slow (b) very fast (c) medium (d) unknown

SHORT / LONG ANSWER QUESTIONS

1. Compare and contrast the mechanism of SN^1 and SN^2 reactions in octahedral complexes.
2. Why do rate laws fail to give information about the mechanism of acid hydrolysis in octahedral complexes?
3. Giving suitable example, describe the reactions without M – L bond breaking.

4. Describe the SN^1CB mechanism involved in base hydrolysis of Co(III) ammine complexes.

MODULE 6:

REACTIONS IN SQUARE PLANAR COMPLEXES

Key words: trans effect; identification of geometrical isomers; Chatt and Orgel theory;

Polarization.

MODULE 6: REACTIONS IN SQUARE PLANAR COMPLEXES

LECTURE #38

1. INTRODUCTION:

The d^8 metal ions like Pt (II), Pd (II) and Ni (II) often form square planar complexes. The square planar complexes of Pt (II) are of particular interest in kinetic studies due to their high stability, ease of synthesis and moderate rates of reaction that enables the monitoring of the reaction. The area of discussion in these complexes is restricted only to the substitution reactions. As compared to the octahedral complexes, the crowding around the metal ion is less in square planar complexes. This is one of the important reasons that most of the substitution reactions in these complexes follow the SN^2 (associative mechanism).

2. THE TRANS EFFECT AND ITS APPLICATIONS

Trans Effect

Consider a substitution reaction

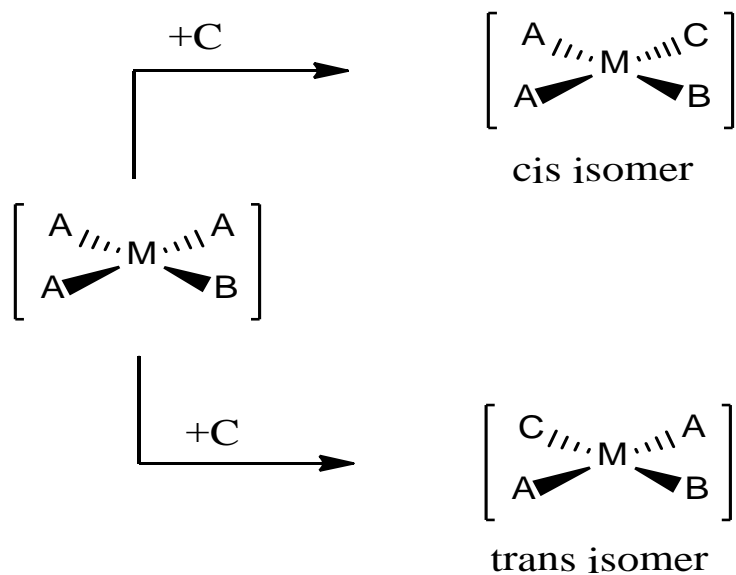

In the above reaction, two isomeric products are possible. However, in practice, only one is formed. Certain ligands are capable of labilising the ligands trans with respect to their position. This induces a facile removal of the labilised ligand and directs the incoming ligand at a trans position with respect to itself. This trans effect is the reason behind the formation of only one isomeric product. The ability of ligands to direct the incoming group at a position which is trans with respect to itself is called trans directing ability.

An approximate order of ligands according to their trans directing ability is shown below:

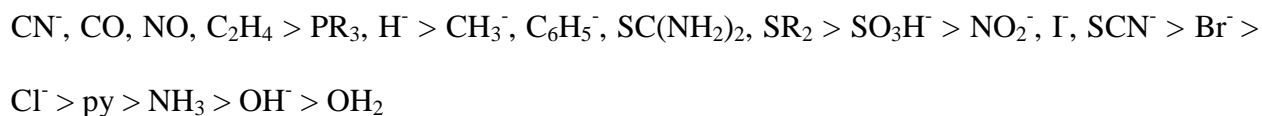

The higher end of the series is occupied by ligands like CN^- , CO , NO , C_2H_4 which are characterized by high π -acidity which is the ability of the ligands to accept the electron density back donated by the metal ion into their low lying vacant π -orbitals.

From amongst the ligands without π -acidity, the most polarizable ones show high trans directing ability. e.g. $I^- > Br^- > Cl^-$.

Applications of trans effect

The knowledge of trans effect while carrying out substitution reactions in square planar complexes has provided two interesting applications.

1. Selective synthesis of desired isomer out of various possible ones.
2. Identification of geometrical isomers.

Selective synthesis

1. By changing the starting material

From the trans directing series, it is seen that Cl^- has higher trans effect than NH_3 ligand. Thus, for the synthesis of $[Pt(NH_3)_2Cl_2]$, if we select $[PtCl_4]^{2-}$ as the starting material and replace the two chloro ligands by ammine ligands sequentially, the first ammine ligand occupies any of the four positions. This is because all the positions are trans with respect to a chloro ligand. For deciding the position of the second incoming ligand, the trans directing ability of Cl^- and NH_3 should be compared. The chloro being more capable of directing the incoming ligand will force the incoming ammine ligand at a trans position with respect to itself resulting into the formation of a cis isomer of $[Pt(NH_3)_2Cl_2]$.

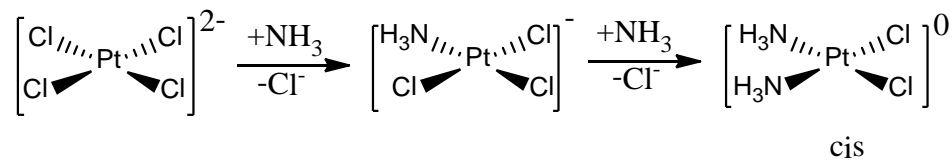

On the other hand, if we start with $[\text{Pt}(\text{NH}_3)_4]^{+2}$, a trans isomer is obtained. Once again, the first incoming chloro ligand can occupy any of the four positions but the second chloro ligand will occupy a position trans with respect to chloro ligand.

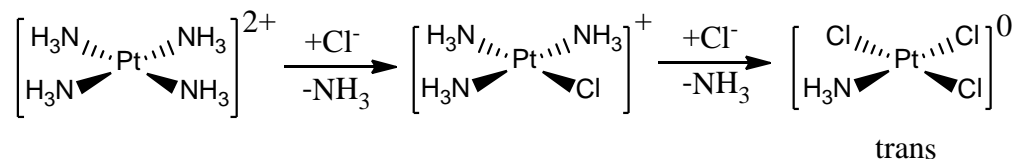

Thus, in the preparation of complexes of type $[\text{Ma}_2\text{b}_2]$, we can generalize that starting with a complex with ligands having lower trans effect yields a trans isomer. While starting with a complex with ligands having higher trans effect yields a cis isomer.

2. By changing the sequence of substitution

The order of trans directing abilities of $\text{NH}_3 < \text{Cl}^- < \text{NO}_2^-$ permits the selective synthesis of isomers of the type $[\text{Ma}_2\text{bc}]$ from $[\text{Ma}_4]$ type of complexes. Consider the preparation of $[\text{Pt}^{+2}\text{Cl}_2(\text{NO}_2)(\text{NH}_3)]$ from $[\text{PtCl}_4]^{-2}$. If the ammonia ligand is introduced in the first step, it can occupy any of the four positions replacing a chloro ligand. In the second step, the incoming NO_2^- is offered a position trans with respect to chlorine due to its higher trans directing ability as compared to ammonia. This results into the formation of a cis isomer of the product. Instead of this, if it is decided to enter the NO_2^- in the first step, once again it can occupy any of the four positions but the position of the ammine ligand to be entered in the second step will be determined on the basis of the trans directing ability of Cl^- and NO_2^- ligands. The NO_2^- having higher trans effect of the two will labilise the Cl^- ligand opposite to it and force the entry of the

ammine group at a trans position with respect to itself. This will result into the formation of a trans isomer.

Thus, in the preparation of complexes of type $[Ma_2bc]$, we can generalize that introduction of the ligand with lower trans effect in the first step results in the formation of a cis isomer. While introducing the ligand having higher trans effect in the first step yields a trans isomer.

The reactions concerning above discussion are shown below:

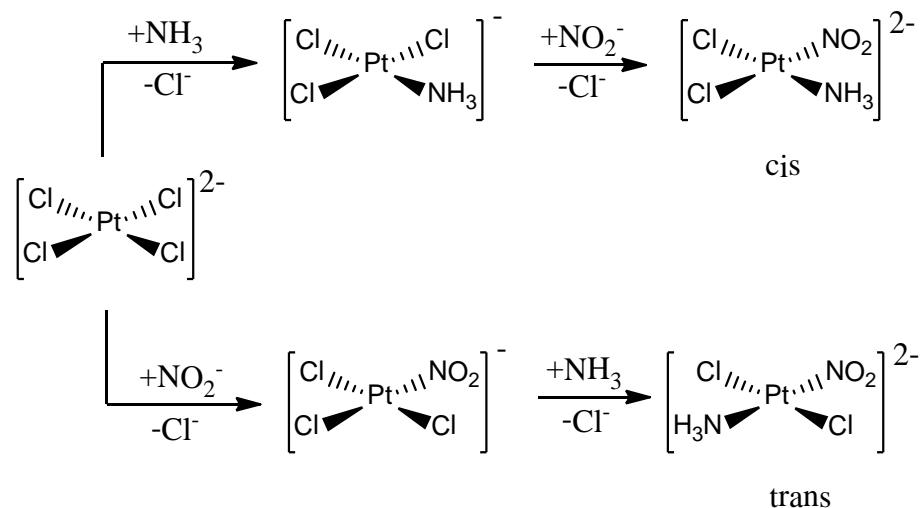

3. By changing the starting material as well as the sequence of substitution

From the above discussion, we have seen that it is possible to prepare a desired isomer by either changing the starting material or altering the sequence of substitution. Three geometrical isomers of the complexes of the type $[Mabcd]$ can be obtained by combining the above two methods. The synthesis of the three isomers of a complex $[Pt(py)(NH_3)ClBr]$ is shown in the reaction scheme below. Here, the trans directing ability of $NH_3 < py < Cl^- < Br^-$ and Pt-N bond is stronger than Pt-Cl bond.

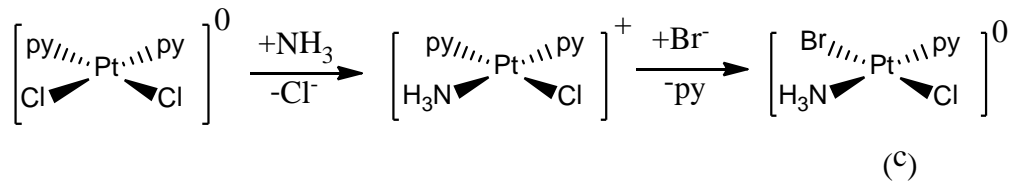
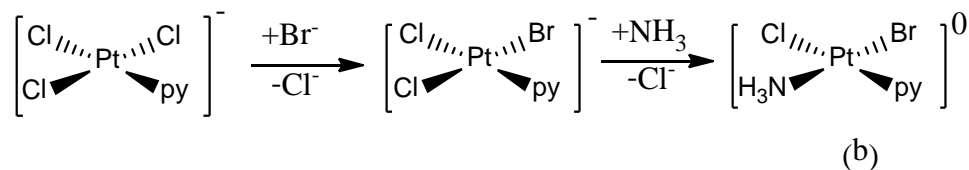
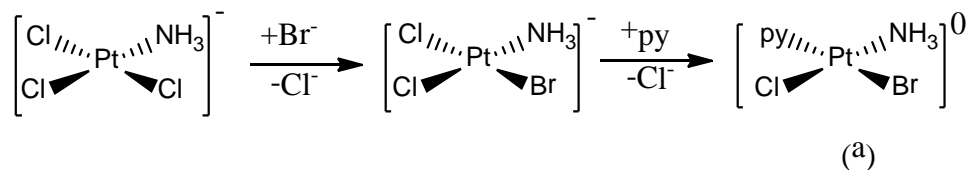

Identification of geometrical isomers.

Kurnakov used the phenomena of trans effect in distinguishing the cis and trans isomers of square planar complexes of $[\text{PtA}_2\text{X}_2]$ type by treating them with thiourea. i.e. (th). Here, Pt-N bond is stronger than Pt-Cl bond and the trans directing ability of th is greater than NH_3 .

While reacting a cis isomer of $[\text{Pt}(\text{NH}_3)_2\text{Cl}_2]$ with th, the two weakly bonded chloro ligands are replaced by th in the first step. In the second step, the th having higher trans directing ability as compared to ammonia, guides two more th molecules to occupy trans positions with respect to themselves. Thus, all the four ligands on the substrate get substituted by thiourea giving $[\text{Pt}(\text{th})_4]$

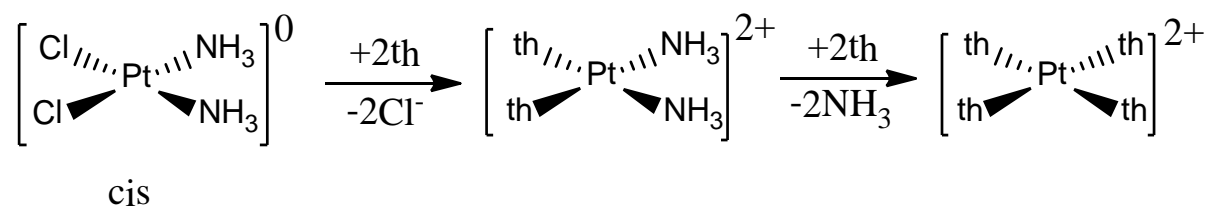

While in case of trans isomer of $[\text{Pt}(\text{NH}_3)_2\text{Cl}_2]$, the two weakly bonded chloro ligands are replaced by th in the first step but in the second step the higher trans effect of th does not allow the ammine ligands to be sufficiently reactive so as to be replaced by the remaining th ligands. Thus, the trans isomer does not permit full substitution by th and gives $[\text{Pt}(\text{NH}_3)_2(\text{th})_2]$.

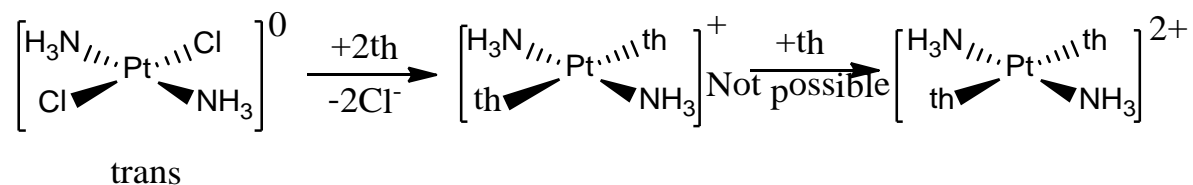

In addition to thiourea, thiosulfate $(\text{S}_2\text{O}_3)^{2-}$ also shows similar reactions with the complexes of type $[\text{PtA}_2\text{X}_2]$.

LECTURE #39

3. THEORIES FOR EXPLAINING TRANS EFFECT

Chatt and Orgel theory

This theory successfully explains the high trans directing ability of ligands with π -acidity. The ligands like CN^- , CO, NO, C_2H_4 , PR_3 have an ability to accept electron density back donated by the metal ion into their low-lying vacant π -orbitals. In the square planar complexes of Pt (II), such ligands accept the electron density from the filled platinum orbitals (d_{yz}) into their suitable vacant p_z or d - orbitals. This results into formation of a π -bond, which increases the electron density between the metal ion and π -acidic ligand (L). The electron density at the bond opposite to this ligand is correspondingly decreased which lengthens this bond and in turn creates a space for the entry of the incoming ligand. Finally, the incoming ligand (Y) occupies a position trans with respect to the π -acidic ligand (L) via 5-coordinated intermediate as shown in the figure.

Diagrams showing the overlapping of the metal-ligand orbitals to form π -bonds are shown in the figure below.

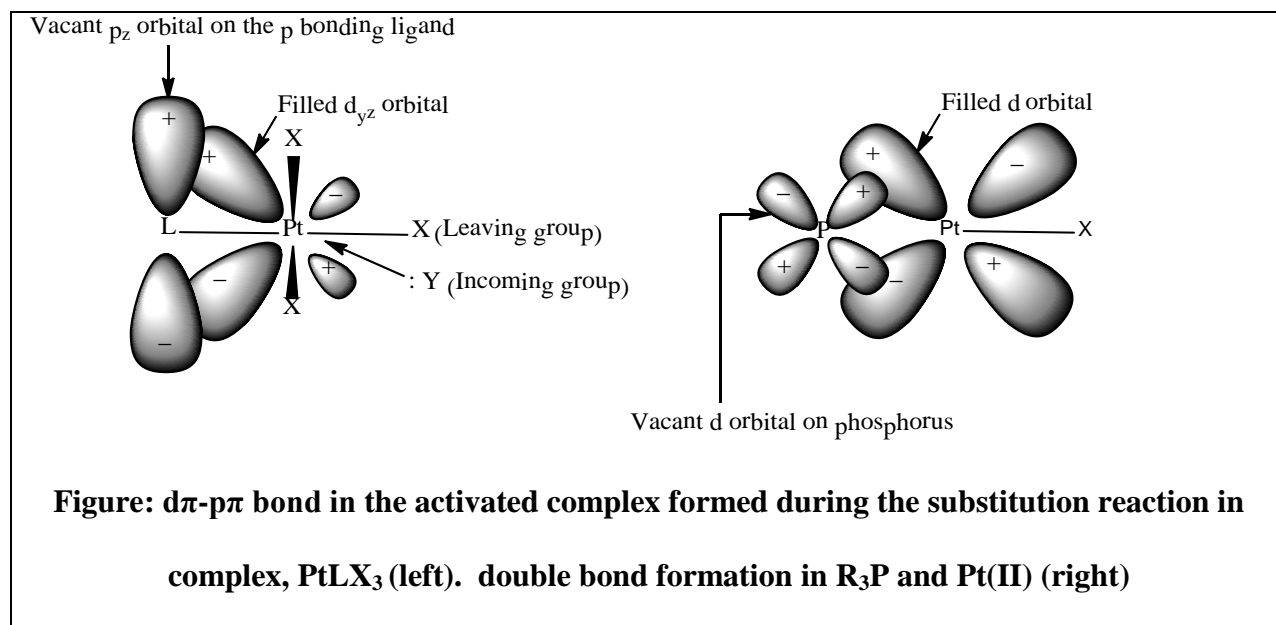

The transfer of electron density from the metal orbitals by the π -acidic ligand L facilitates the entry of the incoming group (Y) and expedites the reaction. Else, the formation of π -bond between the metal and ligand reduces the activation energy for the formation of the activated complex, which increases the speed of the reaction.

Grinberg's polarization theory

According to this theory, the trans directing ability of ligands with greater polarisability is more. For a square planar complex $[PtX_4]$ the trans effect is not operative. Here, the positive charge on the central metal ion induces dipole in the ligands as shown in the figure. Since these dipoles are equal and opposite, they are mutually cancelled and no net trans effect is observed.

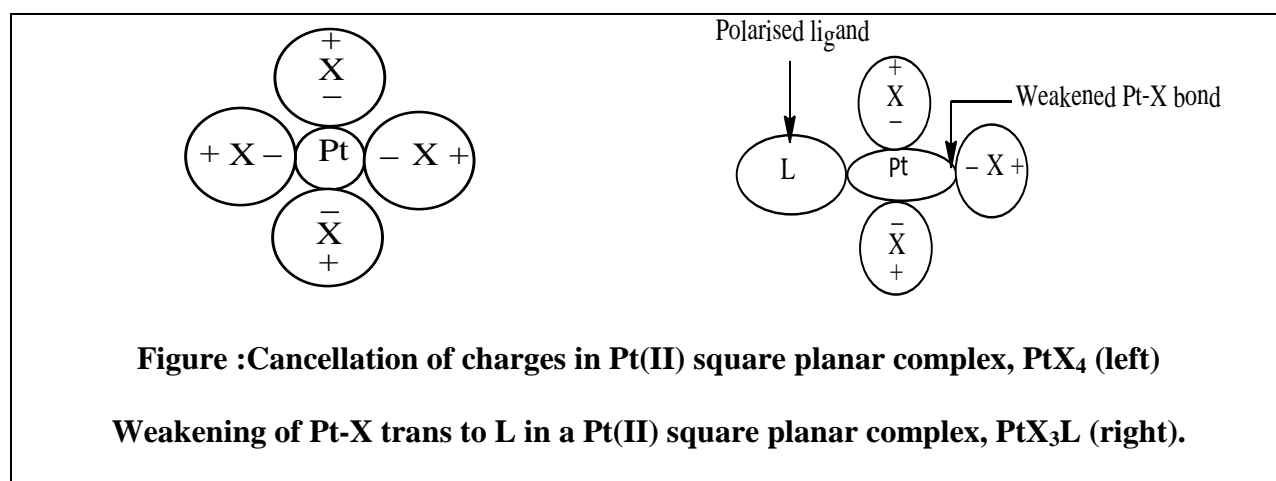

However, in the cases of complexes of type [PtX₃L] as shown in the figure below, the induced dipoles of the two 'X' ligands occupying the trans position get cancelled being equal and opposite. But the induced dipoles for a highly polarisable ligand L occupying a position trans with respect to a ligand 'X' remains non zero. The ligand L now induces a dipole in the Pt (II) in such a way that the positive charge on Pt (II) in the regions opposite to L reduces. This in turn reduces the attraction of Pt (II) for the 'X' ligand opposite to L. This facilitates the replacement of the 'X' ligand trans to L.

The electrostatic polarisation theory predicts that the trans effect is observed only if the central metal ion of the complex is polarisable.

4. MECHANISM OF SUBSTITUTION REACTIONS

As compared to the octahedral complexes, the crowding around the metal ion is less in square planar complexes. Due to this, an associative mechanism (S_N²) is known to be followed in the substitution reactions involving square planar complexes. An associative mechanism with or

without solvent intervention is possible. A mechanism involving the initial coordination of solvent molecule to replace the leaving group followed by the replacement of solvent molecule by entering ligand is called a solvent path. In a path known as reagent path there is no solvent intervention.

The ligand substitution reactions of square planar complexes of Pt (II) of the type PtA_2XL are stereospecific. If the substrate is a cis - isomer, the product is invariably a cis - isomer and vice versa. The reaction occurs via trigonal bipyramidal intermediate as shown in figure below

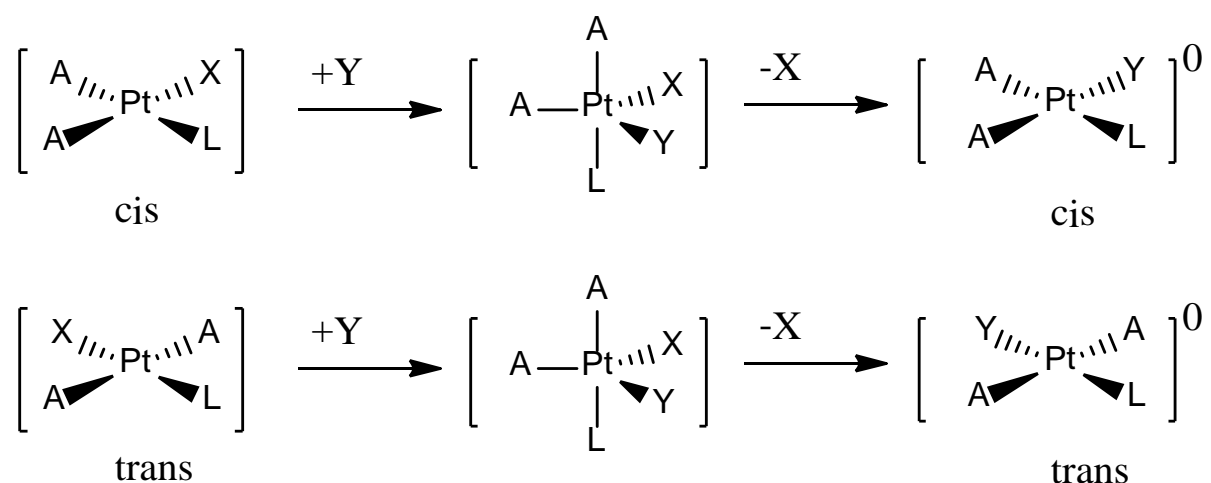

A mechanism involving solvent (H_2O) intervention is possible in a substitution reaction on a square planar complex of type $[\text{PtA}_3\text{X}]$ when performed in an aqueous medium. For the reaction

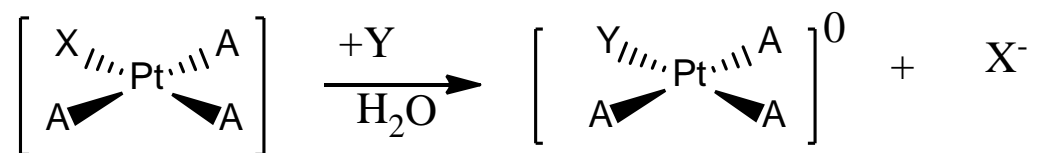

The rate = $K_1 [\text{PtA}_3\text{X}] + K_2 [\text{PtA}_3\text{X}] [\text{Y}]$

Where K_1 and K_2 are first and second order rate constants corresponding to solvent path and reagent path.

The analysis of rate constants can be done using large concentration of nucleophile (Y). Here, the observed rate constant K_{obs} is pseudo first order rate constant which can be given as

$$K_{\text{obs}} = K_1 + K_2 [Y]$$

(This equation is like $y = m x + c$. From X vs Y plot following this type of equation, m is the slope of the line and c is the intercept on Y-axis.)

A plot of nucleophile concentration [Y] against pseudo first order rate constant (K_{obs}) for substitution reactions of various ligands with trans- $[\text{Pt}(\text{py})_2\text{Cl}_2]$ is shown below.

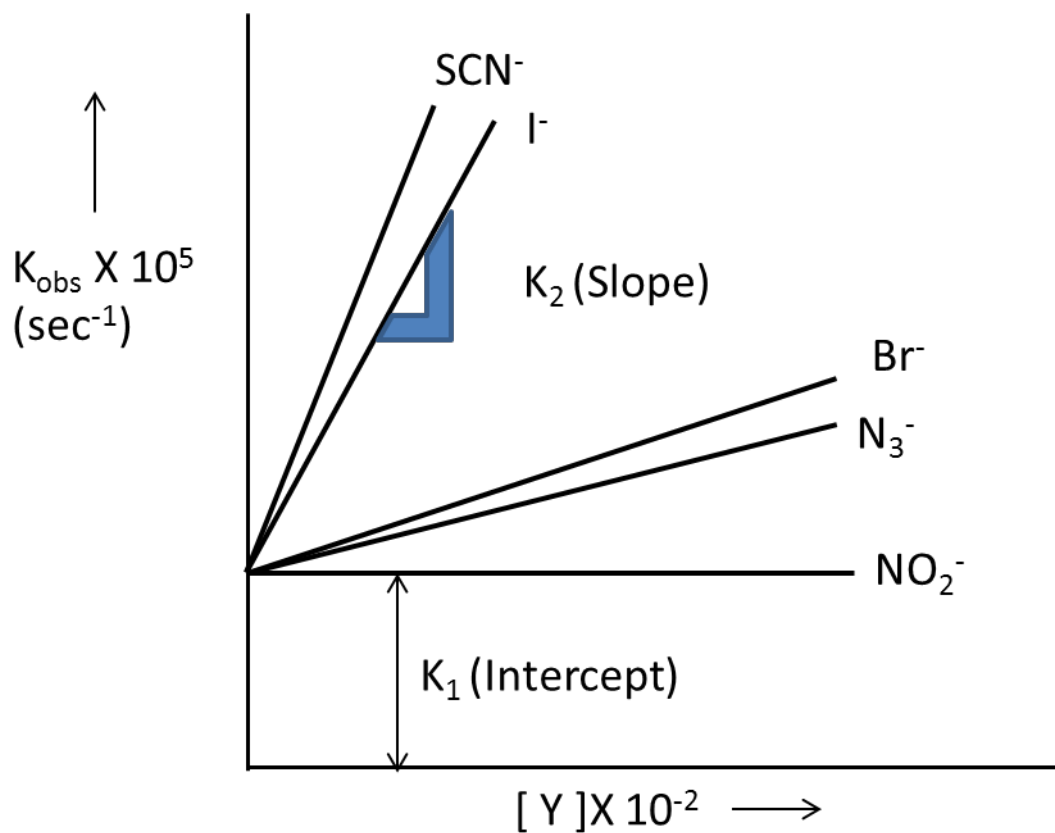

From the above plot, it is seen that the intercept (K_1) for different ligands remains same. However, the slope (K_2) is found to vary with different ligands.

The equation for rate suggests that a substitution reaction on $[\text{PtA}_3\text{X}]$ to give $[\text{PtA}_3\text{Y}]$ follows a two-path mechanism as shown below.

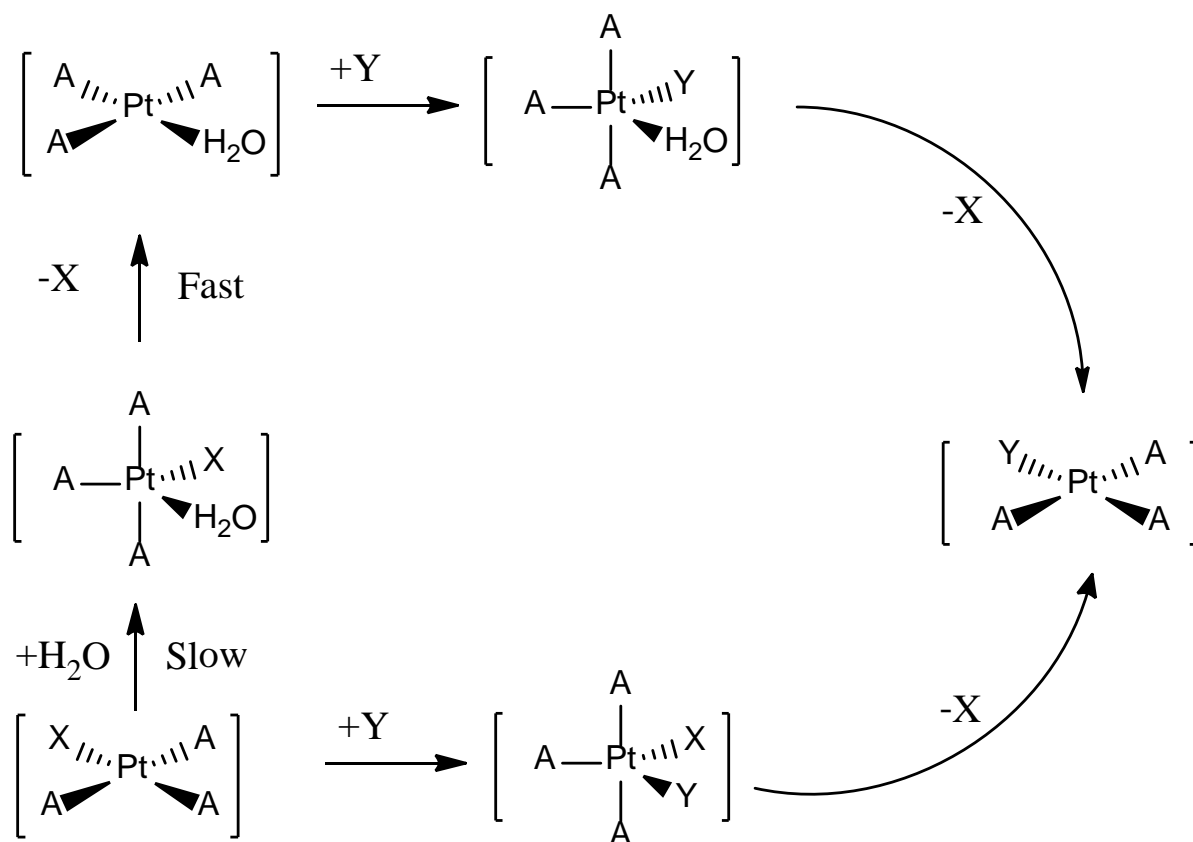

The path shown in clockwise direction is a solvent intervention path. The solvent path follows SN^2 mechanism as shown in the figure. The path shown in anti-clockwise direction is a reagent path.

LECTURE #40**5. FACTORS AFFECTING THE RATE OF SUBSTITUTION REACTIONS IN SQUARE PLANAR COMPLEXES**

The observed rate of substitution reaction in square planar complexes is the result of multifaceted interplay between several factors. The effect of some such factors is summarized below.

<i>FACTOR</i>	<i>COMMENTS</i>
<i>Charge on the complex</i>	<p>An increase in positive charge on the complex increases the difficulty in removing the outgoing ligand, which could decrease the rate of reaction. However, it seems that this decrease in rate of reaction is nearly counterbalanced by increased attraction towards the incoming nucleophile.</p> <p>The complexes $[\text{PtCl}_4]^{-2}$, $[\text{Pt}(\text{NH}_3)\text{Cl}_3]^{-1}$, $[\text{Pt}(\text{NH}_3)_2\text{Cl}_2]$, $[\text{Pt}(\text{NH}_3)_3\text{Cl}]^{+1}$ have progressively increasing positive charge on the complex. However, the rate of hydrolysis for all these complexes is almost same.</p>
<i>Trans effect</i>	<p>The rate of substitution reaction of the complexes of type $[\text{Pt}(\text{NH}_3)\text{Cl}_2\text{L}]$ with pyridine as incoming ligand shows the following</p>

result

trans effect $C_2H_4 > NO_2^- > Br^- > Cl^-$

relative rates $100 > 90 > 3 > 1$

Leaving group

For a reaction

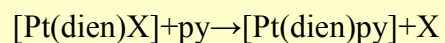

The rate varies with the ligand X as

$NO_3^- > H_2O > Cl^- > Br^- > I^- > N_3^- > SCN^- > NO_2^- > CN^-$

Solvent

The identification of solvent path for the substitution reactions in square planar complexes has increased the importance of solvent effect on the rate.

The solvents with greater coordinating ability show faster rates of substitution reactions.

The observed rate constants for some of the popular solvents vary as

$ROH < H_2O < CH_3NO_2 < (CH_3)_2SO$

EXERCISES

MULTIPLE CHOICE QUESTIONS

- Which one of the following has highest trans directing ability?
 (a) NO_2^- (b) Br^- (c) CN^- (d) Cl^-
- Which one of the following is the correct order of decreasing trans effect?
 (a) $\text{OH}^- > \text{Br}^- > \text{C}_6\text{H}_5^- > \text{H}^- > \text{NO}$
 (b) $\text{Br}^- > \text{C}_6\text{H}_5^- > \text{NO} > \text{OH}^- > \text{H}^-$
 (c) $\text{C}_6\text{H}_5^- > \text{NO} > \text{Br}^- > \text{OH}^- > \text{H}^-$
 (d) $\text{NO} > \text{H}^- > \text{C}_6\text{H}_5^- > \text{Br}^- > \text{OH}^-$
- Substitution reactions of cis & trans PtA_2LX with Y to yield PtA_2LY is _____
 (a) stereospecific (b) stereoselective (c) not possible (d) unknown
- The electrostatic polarization theory can explain the trans effect of the ligands lying at _____ of the trans effect series
 (a) higher end (b) lower end (c) middle (d) alternate positions

SHORT / LONG ANSWER QUESTIONS

1. Give the steps involved in the formation of cis & trans isomers by treating $[\text{Pt}^{\text{II}}\text{Cl}_4]^{2-}$ ion with NH_3 .
2. How to distinguish between cis and trans isomers of $[\text{PtA}_2\text{X}_2]^0$ type complexes?
3. What is trans effect? Explain the applications of “trans-effect” using synthesis of Pt (II) complexes.
4. Discuss the electrostatic polarization theory for trans-effect.
5. Discuss the mechanism of substitution reaction in Pt (II) square planar complexes